

Project	IEEE 802.16 Broadband Wireless Access Working Group < http://ieee802.org/16 >	
Title	RS-initiated Handover Procedure for Handover-manageable RS	
Data	08-JAN-2007	
Submitted		
Source(s)	Woosin Lee, Young-uk Chung, Yong-Hoon Choi, Hyukjoon Lee Kwangwoon University 447-1 Wolgye-Dong, Nowon-Gu Seoul, 139-701, Korea Yong Su Lee, Young-il Kim ETRI 161, Gajeong-dong, Yuseong-Gu, Daejeon, 305-350, Korea	Voice: +82-11-252-3168 Fax: +82-2-915-3168 wlee@kw.ac.kr yuchung@kw.ac.kr yhchoi@kw.ac.kr hlee@kw.ac.kr L7856@etri.re.kr yikim@etri.re.kr
Re:	This is a response to Call for Technical Proposals regarding IEEE Project P802.16j.	
Abstract	This document proposes RS-initiated handover procedures and related messages for an RS which can support handover initiation, process and decision in an IEEE 802.16j network.	
Purpose	The document is submitted for review by 802.16 Working Group members.	
Notice	This document has been prepared to assist IEEE 802.16. It is offered as a basis for discussion and is not binding on the contributing individual(s) or organization(s). The material in this document is subject to change in form and content after further study. The contributor(s) reserve(s) the right to add, amend or withdraw material contained herein.	
Release	The contributor grants a free, irrevocable license to the IEEE to incorporate material contained in this contribution, and any modifications thereof, in the creation of an IEEE Standards publication; to copyright in the IEEE's name any IEEE Standards publication even though it may include portions of this contribution; and at the IEEE's sole discretion to permit others to reproduce in whole or in part the resulting IEEE Standards publication. The contributor also acknowledges and accepts that this contribution may be made public by IEEE 802.16	
Patent Policy and Procedures	The contributor is familiar with the IEEE 802.16 Patent Policy and Procedures < http://ieee802.org/16/ipr/patents/policy.html >, including the statement "IEEE standards may include the known use of patent(s), including patent applications, provided the IEEE receives assurance from the patent holder or applicant with respect to patents essential for compliance with both mandatory and optional portions of the standard. "Early disclosure to the Working Group of patent information that might be relevant to the standard is essential to reduce the possibility for delays in the development process and increase the likelihood that the draft publication will be approved for publication. Please notify the Chair < mailto:chiar@wirelessman.org > as early as possible, in written or electronic form, if patented technology (or technology under patent application) might be incorporated into a draft standard being developed within the IEEE 802.16 Working Group. The Chair will disclose this notification via the IEEE 802.16 web site < http://ieee802.org/16/ipr/patents/notices >.	

RS-initiated Handover Procedure for Handover-manageable RS

Woosin Lee, Young-uk Chung, Yong-Hoon Choi, Hyukjoon Lee, Yong Su Lee and Young-il Kim**

*Kwangwoon University, ETRI**

1 Introduction

This contribution covers the issues related to MAC layer handover procedures defined in Table of Contents of Task Group Working Document [1]. In [2], we have discussed the necessity of RS-initiated handover and defined RS-initiated handover procedure and related messages for handover-unmanageable RS. In this proposal, we present RS-initiated handover procedures and related messages for an RS which is capable of handover initiation, process and decision.

1.1 Problem Statement

In [2], we defined four types of RS according to the supported broadcast frame structure type and the capability of handover initiation, process and decision. Among them, the handover-manageable RS can perform handover process by transmitting MOB_BSHO-REQ to MS's of interest. Before handover process, the handover-manageable RS should negotiate with MR-BS about resource allocation and registration information. The negotiation process is performed by MOB_RSHO-REQ and MOB_RSHO-RSP messages which are defined in [2]. After handover completion, the handover-manageable RS should report the new access station ID of the handovered MS to MR-BS to establish a new downlink path. The reporting process can be performed by relaying MOB_MSHO-IND message to MR-BS. But this way increases signaling overhead as the number of handovered MS increases. For efficiency, new messages and handover procedure are required.

1.2 Assumption

In this proposal, we assume the followings:

1. We follow all the handover procedures in 802.16e for backward compatibility.
2. MR-BS maintains link quality information for RS's and MS's directly connected to it. The link quality information is used for intra-cell handover decision. To obtain the information, network topology acquisition scheme can be employed.
3. RS maintains address information for MS's directly connected to it. The address information contains MAC address, SFID, CID and so on.

MDHO/FBSS and RS-initiated handover for MBS are not covered in this proposal.

2 RS-initiated Handover Procedure of Handover-manageable RS

When an MS initiates handover by transmitting MOB_MSHO-REQ to an RS, the handover-manageable RS selects target access station and informs the result to the MS by transmitting MOB_BSHO-RSP. When MS handover is required, the handover-manageable RS can initiate and perform handover. Using MOB-RSHO-

REQ and MOB-RSHO-RSP messages, the RS initiates handover and perform negotiation with MR-BS. And, the RS performs handover process by transmitting MOB_BSHO-REQ to the MS of interest. When MOB_HO-IND is received from the MS, the RS acquires new access station ID of MS from the received message. The RS should report this information to MR-BS to establish downlink path. For reporting, we define MOB_RSHO-IND message. MOB_RSHO-IND includes address information of the new access station of MS's of interest. Figure 1 shows an example of RS-initiated handover procedure for handover-manageable/asynchronous RS. The general RS-initiated handover procedure for handover-manageable/asynchronous RS is described as follows:

1. An RS shall transmit MOB_RSHO-REQ to an MR-BS so that it initiates handover of specific MS subsets. MOB_RSHO-REQ contains ID's of MS subset.
2. Upon receiving MOB_RSHO-REQ, the MR-BS shall transmit MOB_RSHO-RSP to the RS in response to the request: accept or reject.
3. Upon receiving MOB_RSHO-RSP, the RS acts differently according to the response. When its request is accepted, the RS transmits MOB_BSHO-REQ to each MS of interest. And the RS starts handover procedure with the MS. When its request is rejected, the RS modifies MOB_RSHO-REQ messages according to MOB_RSHO-RSP, and retransmits the modified MOB_RSHO-REQ to the MR-BS.
4. After handover procedure between the RS and all MS of interest is completed (or the RS receives MOB_HO-IND from all MS of interest), the RS transmits MOB_RSHO-IND to the MR-BS.
5. Upon receiving MOB_RSHO-IND, the MR-BS updates access station information and downlink path of the handovered MS subset.

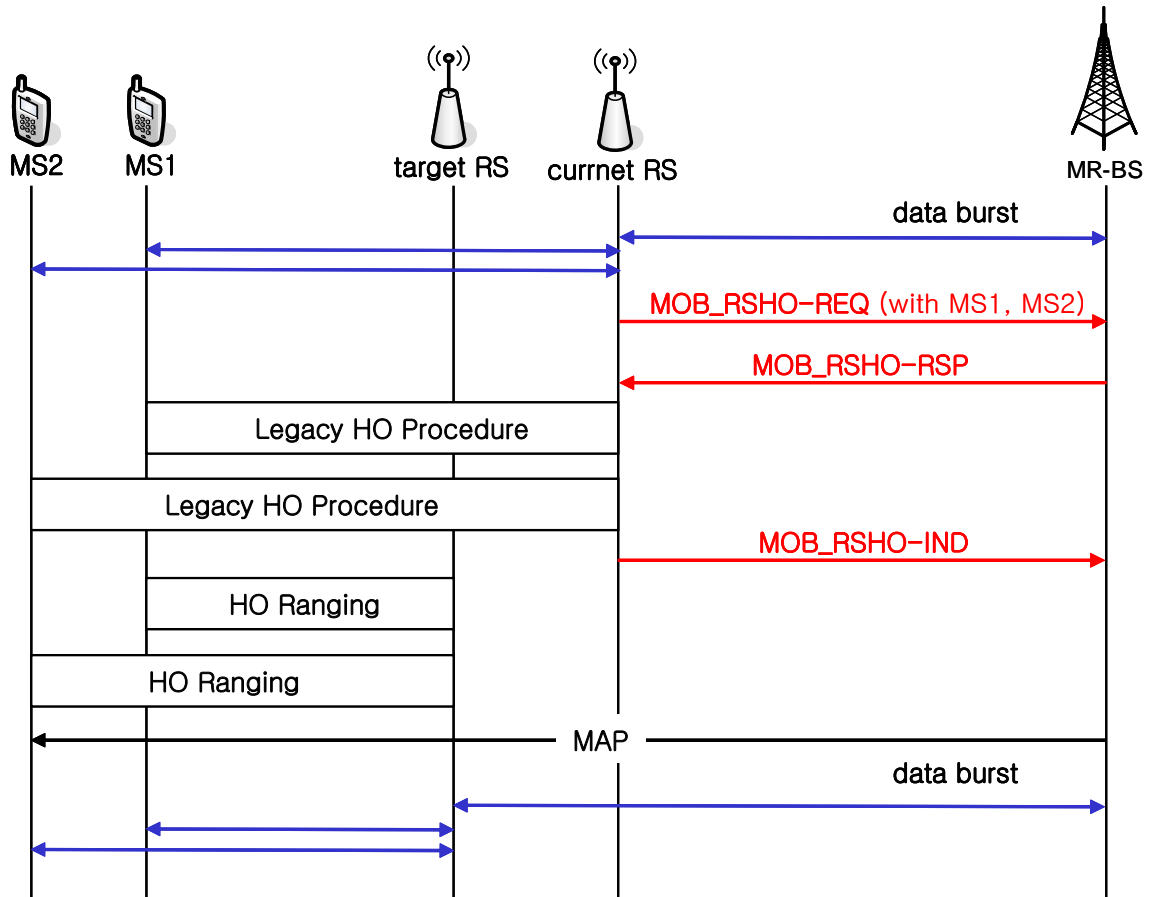

Figure 1 Example of RS-initiated handover procedure with handover-manageable RS

3. Text Proposals

[Insert the following at the end of subclause 6.3.22.2.2]

If an RS can initiate, process and decide handover, handover initiation, process and decision are performed between RS and MS with permission of the MR-BS. In this situation, the RS initiates handover and perform negotiation with MR-BS using MOB-RSHO-REQ and MOB-RSHO-RSP. And, the RS starts handover process by transmitting MOB BSHO-REQ to the MS subset of interest. After handover process is completed, the RS shall report address information of the new access station of the handovered MS subset to MR-BS using MOB RSHO-IND. MOB RSHO-IND is generated based on the MOB HO-IND received from the handovered MS subset. Upon receiving MOB RSHO-IND, the MR-BS updates access station information and downlink path of the handovered MS subset.

[Insert the following text after 6.3.2.3.XX]

6.3.2.3.XX MOB_RSHO-IND

After handover of specific MS subset is completed, an RS shall transmit MOB_RSHO-IND message to MR-BS for reporting address information of the new access station of MS's of interest. Upon receiving this message, the MR-BS updates downlink path information of MS's of interest. The message shall be transmitted on the basic CID.

Table XX–MOB_RSHO-IND message format

<u>Syntax</u>	<u>Size (bits)</u>	<u>Notes</u>
<u>MOB-RSHO-IND Message Format() {</u>		
<u>Management Message Type=XX</u>	<u>XX</u>	
<u>MS Number</u>	<u>XX</u>	<u>Number of handovered MS</u>
<u>For(i=0; i<MS Number; i++) {</u>		
<u>Mobile Station ID</u>	<u>48</u>	
<u>Access Station ID</u>	<u>48</u>	
<u>}</u>		
<u>TLV Encoding Information</u>	<u>variable</u>	<u>optional</u>
<u>}</u>		

A RS shall generate MOB_RSHO-IND messages in the format shown in Table XX. The following parameters shall be included in the MOB_RSHO-IND message:

MS Number

Indicate the number of handovered MS

Mobile Station ID

Indicate the ID of mobile station

Access Station ID

Indicate the ID of new access station

4. Reference

- [1] IEEE 802.16j-06/017r2, "Table of Contents of Task Group Working Document"
- [2] IEEE 802.16j-07/151, "RS-initiated Handover Procedure for Handover-unmanageable RS"