

2007-03-15

IEEE C802.16j-07/250r3

---

Project	IEEE 802.16 Broadband Wireless Access Working Group < <a href="http://ieee802.org/16">http://ieee802.org/16</a> >	
Title	An ARQ with <del>Cooperative Relays</del> in IEEE 802.16j	
Date Submitted	2007-03-06	
Source(s)	<p>Sunggeun Jin, Chulsik Yoon, Young-il Kim, Byung-Jae Kwak Electronics and Telecommunications Research Institute  161 Gajeong-dong, Yuseong-gu, Daejeon, 305-700, Korea</p> <p>Kyu Ha Lee Samsung Thales  San 14, Nongseo-Dong, Giheung-Gu, Yongin, Gyeonggi-Do, Korea 449- 712</p> <p>Chindapol Aik Siemens</p> <p>Yousuf Saifullah Nokia</p>	<p>Voice: +82-42-860-1757 Fax: +82-42-861-1966 sgjin@etri.re.kr</p> <p>Voice:+82-31-280-9917 Fax: +82-31-280-1620 Email: <a href="mailto:kyuha.lee@samsung.com">kyuha.lee@samsung.com</a></p> <p>Email: <a href="mailto:aik.Chindapol@siemens.com">aik.Chindapol@siemens.com</a></p> <p>Email:<a href="mailto:yousuf.saifullah@nokia.com">yousuf.saifullah@nokia.com</a></p>
Re:	This is a response to Call for Technical Proposals regarding IEEE Project P802.16j	
Abstract	The document contains technical proposals for IEEE P802.16j that would provide an ARQ scheme by using multiple cooperative relays	
Purpose	The document is submitted for review by 802.16 Working Group members	
Notice	This document has been prepared to assist IEEE 802.16. It is offered as a basis for discussion and is not binding on the contributing individual(s) or organization(s). The material in this document is subject to change in form and content after further	

---

---

	study. The contributor(s) reserve(s) the right to add, amend or withdraw material contained herein.
Release	The contributor grants a free, irrevocable license to the IEEE to incorporate material contained in this contribution, and any modifications thereof, in the creation of an IEEE Standards publication; to copyright in the IEEE's name any IEEE Standards publication even though it may include portions of this contribution; and at the IEEE's sole discretion to permit others to reproduce in whole or in part the resulting IEEE Standards publication. The contributor also acknowledges and accepts that this contribution may be made public by IEEE 802.16.
Patent Policy and Procedures	The contributor is familiar with the IEEE 802.16 Patent Policy and Procedures < <a href="http://ieee802.org/16/ipr/patents/policy.html">http://ieee802.org/16/ipr/patents/policy.html</a> >, including the statement "IEEE standards may include the known use of patent(s), including patent applications, provided the IEEE receives assurance from the patent holder or applicant with respect to patents essential for compliance with both mandatory and optional portions of the standard." Early disclosure to the Working Group of patent information that might be relevant to the standard is essential to reduce the possibility for delays in the development process and increase the likelihood that the draft publication will be approved for publication. Please notify the Chair < <a href="mailto:chair@wirelessman.org">mailto:chair@wirelessman.org</a> > as early as possible, in written or electronic form, if patented technology (or technology under patent application) might be incorporated into a draft standard being developed within the IEEE 802.16 Working Group. The Chair will disclose this notification via the IEEE 802.16 web site < <a href="http://ieee802.org/16/ipr/patents/notices">http://ieee802.org/16/ipr/patents/notices</a> >.

---

## **An ARQ with Cooperative Relays in IEEE 802.16j**

*Sunggeun Jin, Chulsik Yoon, Young-il Kim, Byung-Jae Kwak,  
ETRI*

*Kyu Ha Lee  
Samsung Thales*

*Aik Chindapol  
Siemens*

*Yousuf Saifullah  
Nokia*

### **Introduction**

ARQ is one of the key technologies that provide reliable transmissions. In IEEE 802.16 standard, an ARQ connection shall exist between Base-Station (BS) and Mobile Station (MS) if it is established. If either a BS or an MS as a receiver having an ARQ connection fails to receive a block, it requests the sender to retransmit the missing block by transmitting ACKnowledgement (ACK) message. Due to the overhead for retransmission, it takes longer to complete transmission when utilizing ARQ. In case that Relay Stations (RSs) are deployed, a block on an ARQ connection should be passed through multiple RSs with increased hop counter, which makes transmission latency longer accordingly. Since a transmitter possibly fails to transmit a block in each wireless link (of a single hop ← necessary?), an RS may receive an erroneous block, where only a single bit can be incorrect. Nevertheless, the whole bits of the block are useless because it is impossible to recover the block. Therefore, it does not need to forward the entire corrupt block to the next destination even on an ARQ connection.

For this reason, in order to reduce the overall latency when using an ARQ connection through multiple RSs over multi-hop, RSs should provide fast recovery of an erroneous block. In this proposal, we provide new scheme called fast recovery to make block retransmission for an ARQ connection fast.

### **Proposal**

An ARQ connection is assumed to be established through multiple RSs over several hops. When an RS receives an erroneous block from either MR-BS or RS, it does not need to forward the corrupt block to the

next destination. Instead, it requests the transmitter to retransmit the corrupt block by sending a retransmission request at the next UL relay zone as soon as possible. For this purpose, a transmitter may keep the transmitted blocks for a while. On successful reception of a block, it continues to relay received block to the next destination. This scheme called fast recovery allows each RS supporting an ARQ connection to recover corrupt block fast, and thus, resulting in reducing retransmission latency when an ARQ connection is established. Both MR-BS and RS shall be aware of the fast recovery, which accelerate ARQ operations intermediately when block transmission failures occur at the wireless links. All of RSs do not need to provide fast recovery necessarily, and so, both MR-BS and MS can establish ARQ connection successfully without providing fast recovery.

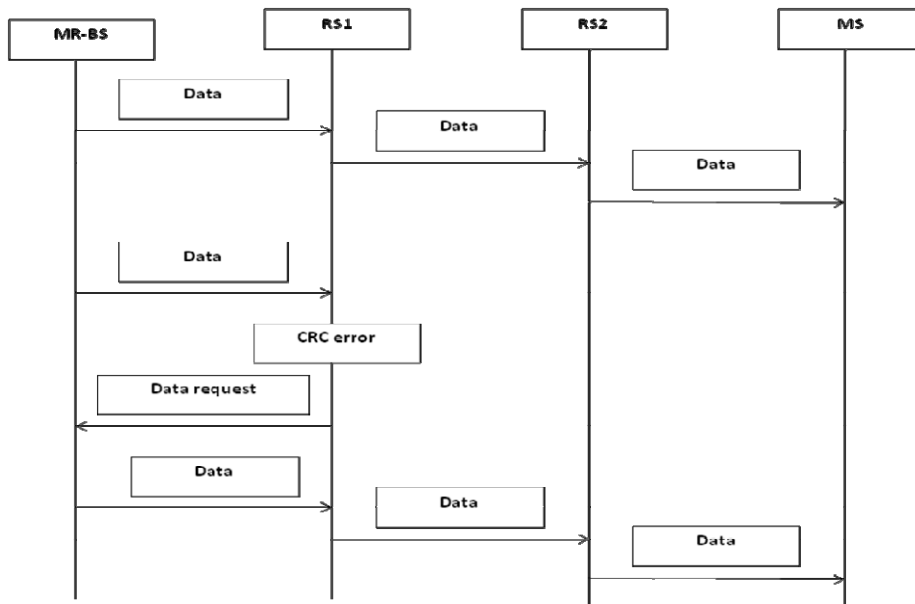

Figure 1 RS requests a corrupt block

Fig. 1 shows an example of fast recovery. When RS1 recognizes the received block is corrupt by checking CRC, it drops and requests a retransmission of the corrupt block. On reception of the request, MR-BS retransmits the corrupt block to RS1, and then, RS1 forwards the received block to RS2.

Cooperative relay technology is one of key technologies in the 802.16j. By using cooperative relays, two or more relays cooperate to transmit a single block in a synchronous manner. It can provide higher Signal-to-Noise-Ratio (SNR) compared with using a single relay. When cooperative relays are deployed, an MR-BS should configure those relays to transmit the same block synchronously. In order to enhance the benefits

that cooperative relays can offer, multiple paths for a single ARQ connection need to be allowed to forward the same blocks along with each path.

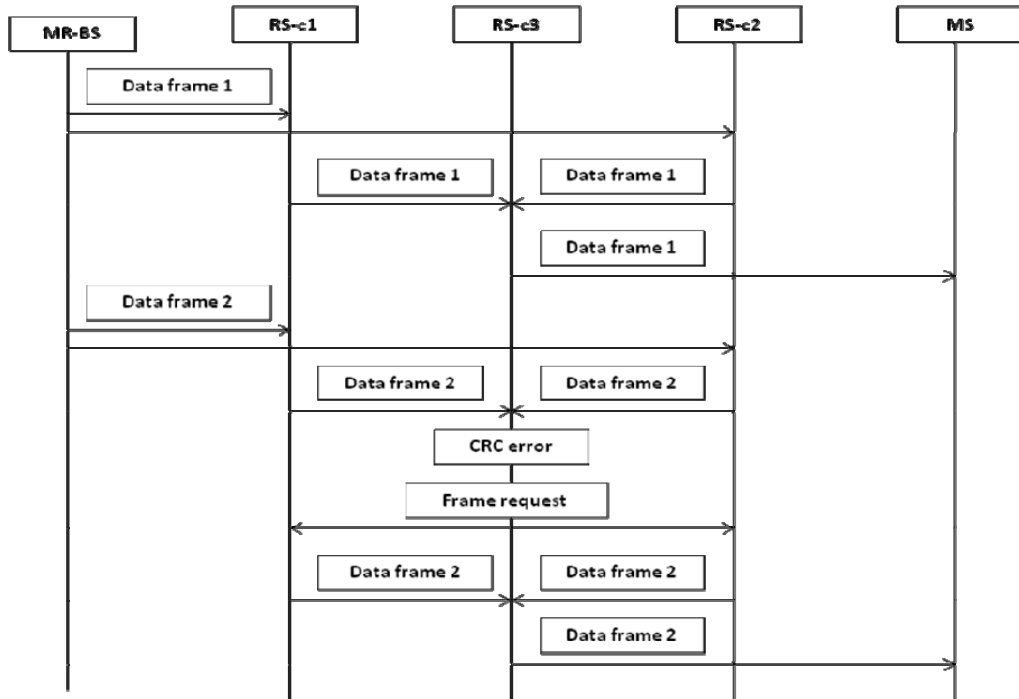

Figure 2 Fast recovery with cooperative relays.

Fig. 2 depicts an example of fast recovery when cooperative relays are utilized. MR-BS transmits a block to both RS-c1 and RS-c2. Both forward the block to RS-c3, which relays it to an MS. When an RS fails to receive a block because of CRC error, it requests a block retransmission to both RS-c1 and RS-c2, and then, they retransmit it to RS-c3.

In order to configure RSs for ARQ connection establishment, MR-BS utilizes DSA-REQ containing Traffic Connection ID (TCID) assigned for an ARQ connection.

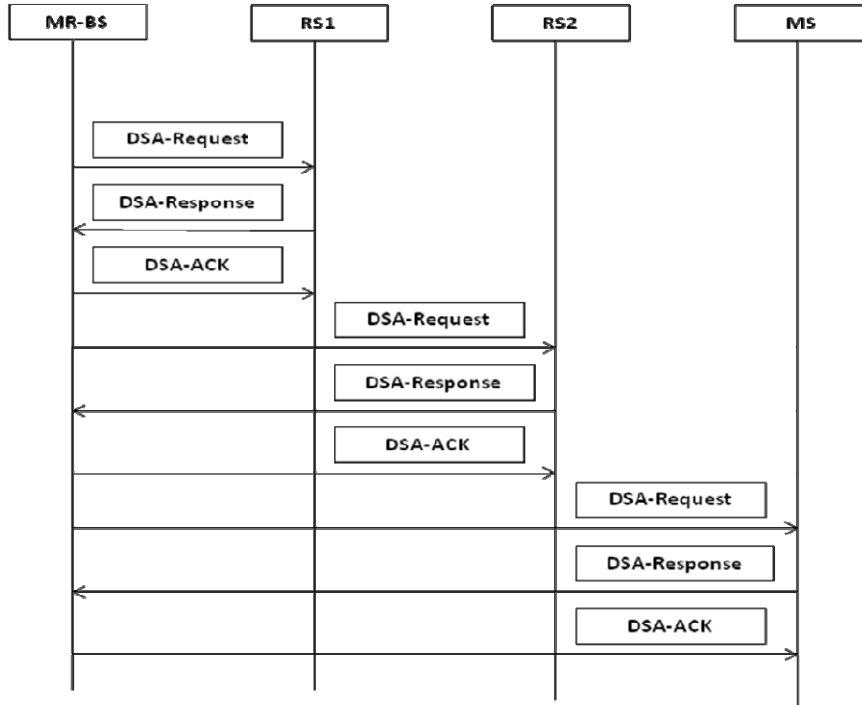

Figure 3 ARQ connection establishment triggered by an MR-BS

Fig. 3 shows a procedure to establish an ARQ connection when an MR-BS decides to create an ARQ connection. MR-BS configures RSs in advance before it requests an MS to make an ARQ connection. DSA-REQ contains TCID issued by an MR-BS. The TCID will be transferred to an MS after completing an ARQ connection establishment in each RS.

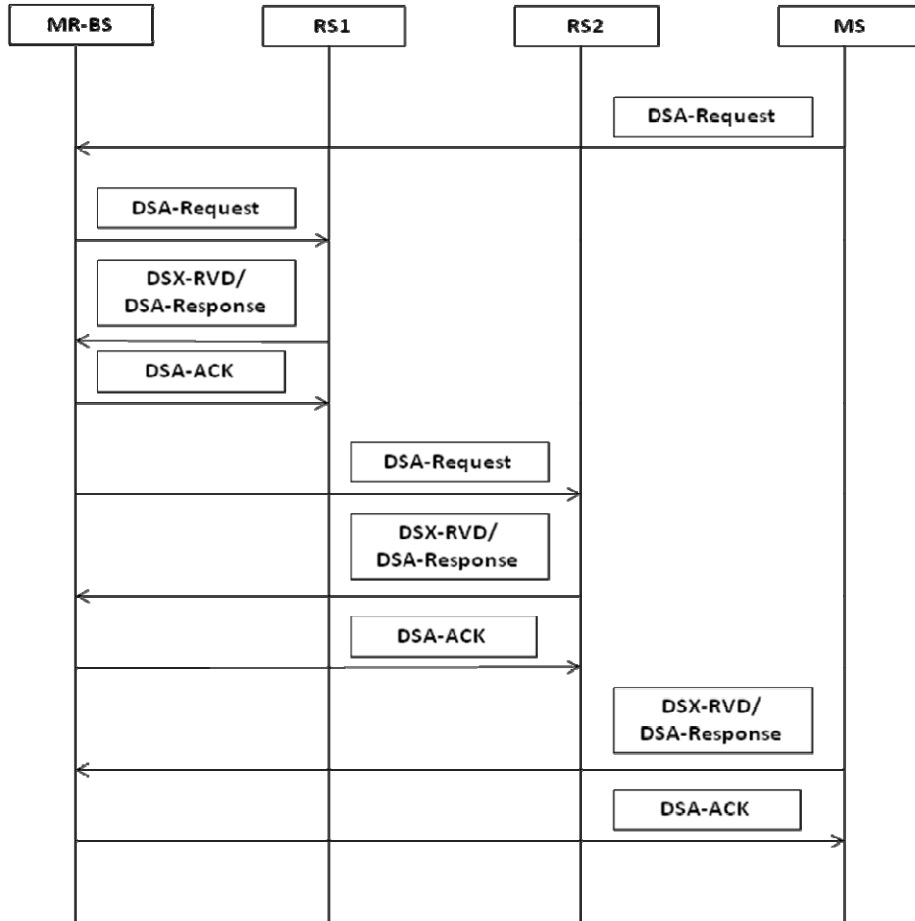

Figure 4 ARQ connection establishment triggered by an MS

Fig. 4 shows a procedure to establish ARQ connection when an MS decides to create an ARQ-connection. On receiving an DSA-REQ, an MR-BS begins to configure RSs to support the requested ARQ connection. After finishing the configurations over RSs, it transmits DSA-RSP to the MS.

## Text Proposal

[Insert the text at the section 6.3.4.6.4 as follows]

Either an MR-BS or an MS may establish a single ARQ connection terminated at an MS or an MR-BS respectively across multiple RSs over multiple hops. If an RS receives a block with invalid CRC via ARQ connection, it may request the transmitter, i.e., the MR-BS or an RS, to retransmit the incorrectly received block by transmitting a NACK management message represented by ACK-Feedback management message. If there is nothing to be retransmitted, it may send NACK with the SN of the last block incremented by one. The retransmission request may repeat up to ARQ FAST RECOVERY RETRIAL LIMIT times, the determination of whose value is beyond the scope of this standard. Otherwise, it forwards the block to the next destination. This retransmission scheme is referred to as fast recovery. RS shall not relay incorrect blocks to the next destination on an ARQ connection. However, it may not have the capability for the fast recovery.

[Change the text at the section 6.3.2.3.30 as follows]

A system supporting ARQ shall be able to receive and process the ARQ Feedback message. The ARQ Feedback message, as shown in Table 59-a, can be used to signal any combination of different ARQ ACKs (cumulative, selective, selective with cumulative) between both BS and MS, or ARQ NACKs for fast recovery only in relay links. The message shall be sent on the appropriate basic management connection.

[Insert the following entry into Table 381 – Service flow encodings:]

Type	Parameter
47	<u>ARQ FAST RECOVERY RETRIAL LIMIT</u>

[Insert the text at the section 11.13.18.9 as follows]

### 11.13.18.9 ARQ FAST RECOVERY RETRIAL LIMIT

The value of this parameter specifies the retransmission request limit for fast recovery. An MR-BS can set a value for this parameter. If an RS accepts the value of this parameter, it replies with the same value as requested. Otherwise, it determines its own value, and then, replies to an MR-BS. The value of zero indicates that fast recovery is not supportable.



<u>Type</u>	<u>Length</u>	<u>Value</u>	<u>Scope</u>
<a href="#">[145/146].47</a>	<a href="#">1</a>	<a href="#">0-255</a>	<a href="#">DSA-REQ</a> <a href="#">DSC-REQ</a> <a href="#">DSA-RSP</a> <a href="#">DSC-RSP</a>