

Project	IEEE 802.16 Broadband Wireless Access Working Group < <a href="http://ieee802.org/16">http://ieee802.org/16</a> >	
Title	On the issue of frame alignment and gaps	
Date Submitted	2007-03-13	
Source(s)	Charlie Huo, Aram Sukyasian, Dorin Viorel Fujitsu Microelectronics Canada Inc.	Voice: +1 403 207 6334; <a href="mailto:chuo@fmci.fujitsu.com">chuo@fmci.fujitsu.com</a>
	Mike Hart Fujitsu Laboratories Europe	Voice: +44 20 86064523; <a href="mailto:mike.hart@uk.fujitsu.com">mike.hart@uk.fujitsu.com</a>
	Michiharu Nakamura Fujitsu Laboratories Japan	Voice:: +81 468 39 5371; <a href="mailto:michi@labs.fujitsu.com">michi@labs.fujitsu.com</a>
	Mark Naden , Israfil Bahceci, Hang Zhang, Peiyong Zhu, Mo-Han Fong, Wen Tong, David Steer, Gamini Senarath, Derek Yu, G.Q. Wang Nortel, Ottawa, On, K2H 8E9 Canada	Voice: +1-613 7635972 <a href="mailto:gamini@nortel.com">gamini@nortel.com</a>
	Changyoon Oh, Youngbin Chang, Mihyun Lee, HyoungKyu Lim, Jaeweon Cho, Panyuh Joo Samsung Electronics 416, Maetan-3dong, Youngtong-gu, Suwon-si, Gyeonggi-do, Korea	Voice: +82-31-279-7529 Fax: +82-31-279-5130 mail to: <a href="mailto:changyoon.oh@samsung.com">changyoon.oh@samsung.com</a>
Re:	<a href="#">80216j-07_007r2</a> : "Call for Technical Comments and Contributions regarding IEEE Project 802.16j"	
Abstract	This document provides information relating to the specification of the R-TTG and R-RTG gap durations for in the case of different frame alignment scenarios.	
Purpose	Text proposal for 802.16j Baseline Document	
Notice	This document has been prepared to assist IEEE 802.16. It is offered as a basis for discussion and is not binding on the contributing individual(s) or organization(s). The material in this document is subject to change in form and content after further study. The contributor(s) reserve(s) the right to add, amend or withdraw material contained herein.	
Release	The contributor grants a free, irrevocable license to the IEEE to incorporate material contained in this contribution, and any modifications thereof, in the creation of an IEEE Standards publication; to copyright in the IEEE's name any IEEE Standards publication even though it may include portions of this contribution; and at the IEEE's sole discretion to permit others to reproduce in whole or in part the resulting IEEE Standards publication. The contributor also acknowledges and accepts that this contribution may be made public by IEEE 802.16.	
Patent	The contributor is familiar with the IEEE 802.16 Patent Policy and Procedures < <a href="http://ieee802.org/16/ipr/patents/policy.html">http://ieee802.org/16/ipr/patents/policy.html</a> >, including the statement "IEEE standards may	

---

Policy and Procedures include the known use of patent(s), including patent applications, provided the IEEE receives assurance from the patent holder or applicant with respect to patents essential for compliance with both mandatory and optional portions of the standard." Early disclosure to the Working Group of patent information that might be relevant to the standard is essential to reduce the possibility for delays in the development process and increase the likelihood that the draft publication will be approved for publication. Please notify the Chair <<mailto:chair@wirelessman.org>> as early as possible, in written or electronic form, if patented technology (or technology under patent application) might be incorporated into a draft standard being developed within the IEEE 802.16 Working Group. The Chair will disclose this notification via the IEEE 802.16 web site <<http://ieee802.org/16/ipr/patents/notices>>.

---

# On the issue of frame alignment and gaps

Dorin Viorel, Charlie Huo, Mike Hart, Michiharu Nakamura, Aram Sukyasian  
Fujitsu

Mark Naden , Israfil Bahceci, Hang Zhang, Peiyong Zhu, Mo-Han Fong, Wen Tong, David Steer, Gamini  
Senarath, Derek Yu, G.Q. Wang  
Nortel, Ottawa, On, K2H 8E9 Canada

Changyoon Oh, Youngbin Chang, Mihyun Lee, HyoungKyu Lim, Jaeweon Cho, Panyuh Joo  
Samsung Electronics

## 1. Introduction

In order to provide support for the one radio RS operation as defined by 802.16j, new gaps (R-TTG and R-RTG) have been introduced, in order to avoid any data drops due to the Tx/Rx and Rx/Tx switching times. This contribution provides some information on the size of these gaps based on the arrangement of the DL and UL subframe start time arrangement between the MR-BS and RSs.

## 2. Details

These two new gaps have the unique scope to provide a sufficient time for the radio transceiver or sets of transceivers (if diversity schemes are implemented) to properly switch from Tx to Rx or from Rx to Tx.. These gaps were not intended to provide any functionality for any ranging operations. Ideally, if the gaps can be 1 symbol in duration then this will ease implementation. However, the actual gap required depends on the alignment arrangement of the DL and UL subframe start points between the MR-BS and RS, thus any alignment requirements need to be carefully considered in conjunction with the impact of the R-TTG and R-RTG durations and what these results in, in terms of the gaps between zones at the MR-BS or RS.

In order to demonstrate this, Figure 1 shows the frame arrangement when the round trip delay between the MR-BS and RS is not compensated for. Consequently the frame start time at the RS is delayed by  $RTD/2$  relative to the frame start time at the MR-BS. Likewise the UL subframe start time is advanced by  $RTD/2$  relative to the UL subframe start at the MR-BS. Such arrangement would be required when the RS is performing network entry. If this arrangement is maintained when the RS becomes operational, switching the transmit in the DL access zone interval and receive in the UL access zone interval after network entry, then it can be seen that the RS-TTG and RS-RTG will be an integer number of symbols.

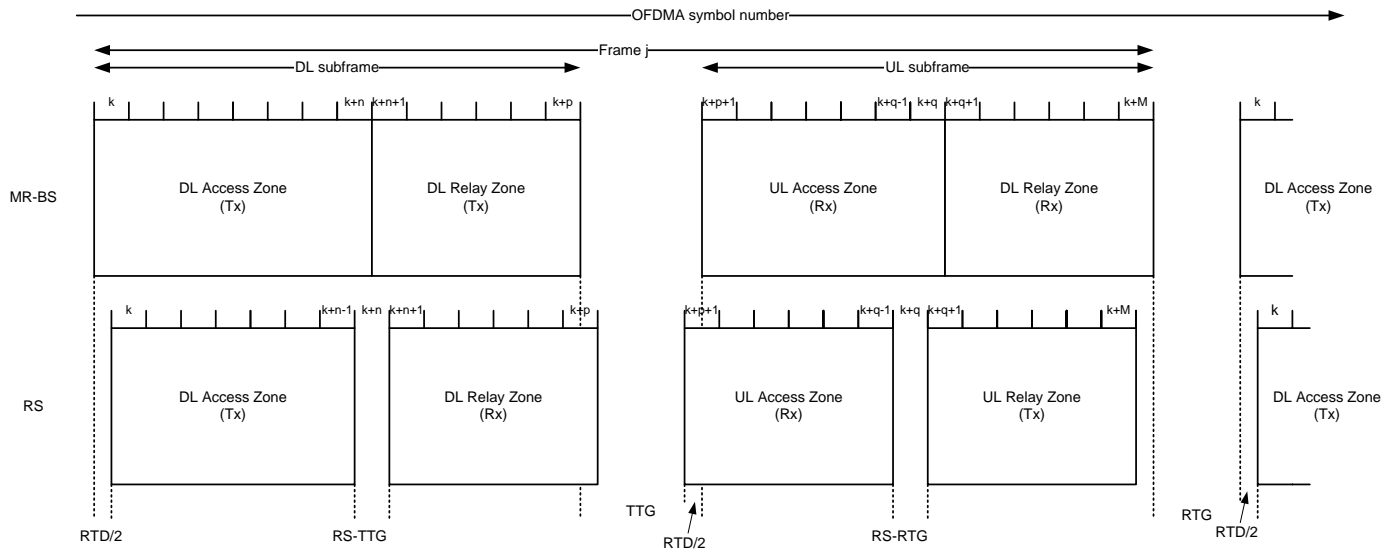

Figure 1. Frame alignment with no modification to timing after network entry.

However, if the frame alignment is adjusted after network entry such that the DL and UL subframe start times are aligned, as shown in Figure 2, then the impact is that the gaps for R-RTG and R-TTG will no longer be an integer number of symbols at either one of the MR-BS or RS, due to the fact that whilst the relative position of the access zone at the RS in the DL and UL is now different compared to the case in Figure 1, the relative timing between the relay zones is the same. Thus the adjustment in the access zone start point is absorbed into the gap between the access and relay zones.

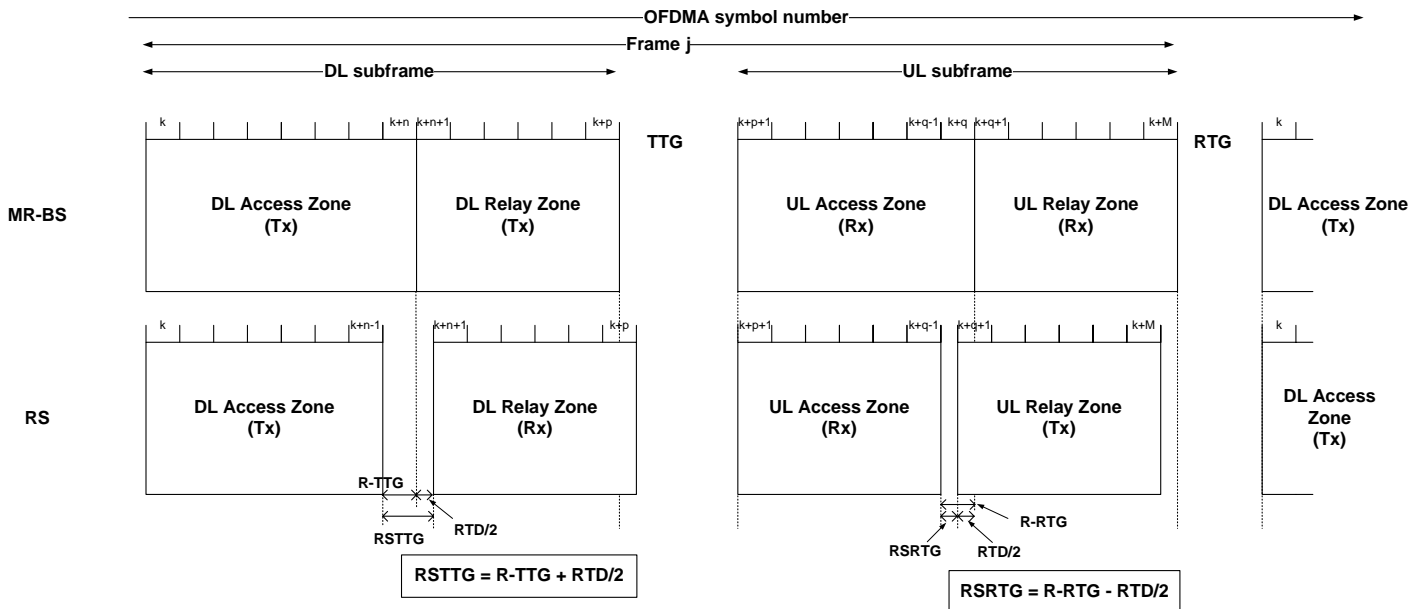

Figure 2. Frame alignment with modification to timing after network entry.

Note that in the case of Figure 2 it is assumed the OFDMA symbol spacing across the DL and UL subframe is maintained, else it will render the remainder of the subframe after the access interval useless for communications between a .16e MS and the MR-BS. It would therefore prevent the operation of features such as the common sync symbol. The consequence is that the RS must support gaps which are not an integer number of symbols. In fact the RS-TTG is an integer number of symbols plus  $RTD/2$ , whereas the RS-RTG is an integer number of symbols minus  $RTD/2$ .

### 3. Specific text changes

*Insert new Clause #3. Definitions*

**3.xx RSRTG:** RS receive/transmit transition gap (RSRTG): A gap between the last sample of the uplink burst in access zone and the first sample of the subsequent uplink burst in relay zone at the antenna port of the relay station (RS) in a time division duplex (TDD) transceiver. This gap allows time for the relay station (RS) to switch from receive to transmit mode. Not applicable for frequency division duplex (FDD) systems.

**3.xx+1 RSTTG:** RS transmit/receive transition gap (RSTTG): A gap between the last sample of the downlink burst in access zone and the first sample of the subsequent downlink burst in relay zone at the antenna port of the relay station (RS) in a time division duplex (TDD) transceiver. This gap allows time for the relay station (RS) to switch from transmit to receive mode. Not applicable for frequency division duplex (FDD) systems.

**3.xx+2 R-RTG:** RS receive/transmit transition gap between uplink access zone and uplink relay zone in RS frame. It shall be an integer number of symbols. Not applicable for frequency division duplex (FDD) systems. **The R-RTG is calculated by following equations:**

$$\mathbf{R-RTG} = \lceil \text{OFDM symbol unit}(\mathbf{RSRTG} + \mathbf{RTD}/2) \rceil$$

**3.xx+3 R-TTG:** RS transmit/receive transition gap between uplink access zone and uplink relay zone in RS frame between DL access zone and DL relay zone in RS frame. It shall be an integer number of symbols. Not applicable for frequency division duplex (FDD) systems.

$$\mathbf{R-TTG} = \begin{cases} 0, & \text{if } \mathbf{RTD}/2 \geq \mathbf{RSTTG} \\ \lceil \text{OFDM symbol unit}(\mathbf{RSTTG} - \mathbf{RTD}/2) \rceil & \text{if } \mathbf{RTD}/2 < \mathbf{RSTTG} \end{cases}$$

*Insert new sub-clause #8.4.4.2:*

In TDD and H-FDD systems, relay station allowances must be made by a RSRTG and by a RSTTG. The relay station shall not transmit downlink information to its subscribed stations later than (RSTTG-RTD/2) before the beginning of DL relay zone. The relay station shall not receive uplink information from its subscribed station later than RSRTG+RTD/2 before the beginning of the UL relay zone. The parameters of RSRTG and RSTTG are capabilities provided by the RS to MR-BS upon request during network entry (see 11.8.3.1).

*Insert in sub-clause #8.4.4.7.2.2 after the 1st paragraph:*

The DL sub-frame of the RS shall be also time aligned with the DL sub-frame of the MR-BS

*Insert in sub-clause #8.4.4.7.2.2 after the 2nd paragraph:*

The UL sub-frame of the RS is aligned to the UL sub-frame of the MR-BS

*Update Table 413 [2] Minimum Performance Requirements for all profiles:  
RSTTG and RSRTG  
TDD $\leq$ 50 us*

## References

1. C802.16j-07/102r2, "Frame Alignment Requirements"
2. IEEE802.16e-2005