

Project	IEEE 802.16 Broadband Wireless Access Working Group < http://ieee802.org/16 >	
Title	Private Map Message and CQICH Direct Signaling in the AAS Relay Zone.	
Date Submitted	2008-03-18	
Source(s)	Dale Branlund, Matt Volpe, Will Sun BRN Phoenix Inc. 2500 Augustine Drive Santa Clara, CA, USA 95054	Voice: +1-408-572-9703 Fax: +1-408-351-4911 dbranlund@brnphoenix.com
	John Norin, Robert Popoli The DIRECTV Group, Inc. 2250 East Imperial Hwy El Segundo, CA 90245	Voice: +1-310-964-0717 Fax: +1-310-535-5422 john.norin@directv.com
Re:	Working Group Letter Ballot Recirc #28b, Technical Comments and Contributions regarding IEEE Project P802.16j; Draft Amendment P802.16j/D3.	
Abstract	This contribution describes the Direct Signaling Private Map message transmitted in the AAS Relay Zone to accomplish bandwidth grant, physical link adjustment and fast HARQ feedback.	
Purpose	This document provides the necessary messaging to properly accomplish bandwidth grant and HARQ control within the AAS Relay Zone for Direct Signaling mode of operation.	
Notice	<i>This document does not represent the agreed views of the IEEE 802.16 Working Group or any of its subgroups.</i> It represents only the views of the participants listed in the "Source(s)" field above. It is offered as a basis for discussion. It is not binding on the contributor(s), who reserve(s) the right to add, amend or withdraw material contained herein.	
Release	The contributor grants a free, irrevocable license to the IEEE to incorporate material contained in this contribution, and any modifications thereof, in the creation of an IEEE Standards publication; to copyright in the IEEE's name any IEEE Standards publication even though it may include portions of this contribution; and at the IEEE's sole discretion to permit others to reproduce in whole or in part the resulting IEEE Standards publication. The contributor also acknowledges and accepts that this contribution may be made public by IEEE 802.16.	
Patent Policy	The contributor is familiar with the IEEE-SA Patent Policy and Procedures: < http://standards.ieee.org/guides/bylaws/sect6-7.html#6 > and < http://standards.ieee.org/guides/opman/sect6.html#6.3 >. Further information is located at < http://standards.ieee.org/board/pat/pat-material.html > and < http://standards.ieee.org/board/pat >.	

Private Map Message and CQICH Direct Signaling in the AAS Relay Zone

*Dale Branlund, Will Sun, Matt Volpe, BRN Phoenix, Santa Clara, CA, USA;
John Norin, Robert Popoli, The DIRECTV Group, Inc., El Segundo, CA, USA*

This document provides the necessary messaging to properly accomplish bandwidth grant and HARQ control within the AAS Relay Zone for Direct Signaling mode of operation.

Background

Direct Signaling operation within the relay zone provides a bandwidth request mechanism that can scale with an M-fold increase in the number of users afforded by multi-user beamforming.

Section 8.4.4.7.2.3 of Draft Amendment P802.16j/D3 describes the AAS Relay Zone but does not detail the messaging required for managing private map bandwidth grant, range/frequency/power adjustment and CQICH signaling.

Proposed Solution

The proposed solution is to describe the bandwidth grant, link adjustment mechanism and CQICH signaling as well as the required Direct Signaling Access Messages to accomplish it within the AAS Relay Zone.

Detailed Solution

Overview

The AAS-DS Private Map structure provides information for supporting bandwidth grant. AAS-DS Resource allocation utilizes the follow definitions:

- 1) Partition – a partition of frequency within the carrier channel. AAS-DS partitions utilize AMC slots and are therefore comprised of 1 or 2 bins as defined by the AMC subchannel permutation (1 bin x 6 symbols or 2 bins x 3 symbols). The partition is the smallest unit of allocation granularity within a burst for the AAS Relay Zone. Partitions are numbered with an index in ascending order based on frequency (starting with an index of 0). A partition allocation is a coupled resource allocation which is granted in both the DL subframe and UL subframe for each frame of allocation.
- 2) Burst – a burst is the unit resource allocation within the AAS zone. A burst is comprised of 1 to 8 partitions. The AAS zone can support 1 to 4 bursts per user. Bursts are defined to be HARQ enabled or disabled within the partition control structure described in the Private Map Message section.
- 3) Partition Control actions
 - a) Probe – a training preamble that allows the BS to unobtrusively determine interference characteristics between the probing users and current active users within a single partition of frequency.
 - b) Open – an allocation grant of the partition resource
 - c) Close – a de-allocation of the partition resource

- d) Maintain – maintain the allocation of partition resource (used to maintain synchronization of partition resource allocation between the BS and RS since the partition controls are all delta state related.).

The initial ranging message sequence for an entering RS shows the migration from the Access partition utilizing the DLA for bandwidth grant and physical layer control to a traffic partition as part of a burst allocation where the PMAP is then used for bandwidth grant and physical layer control. The initial ranging message sequence for an RS entering the network in the AAS Relay zone is as follows:

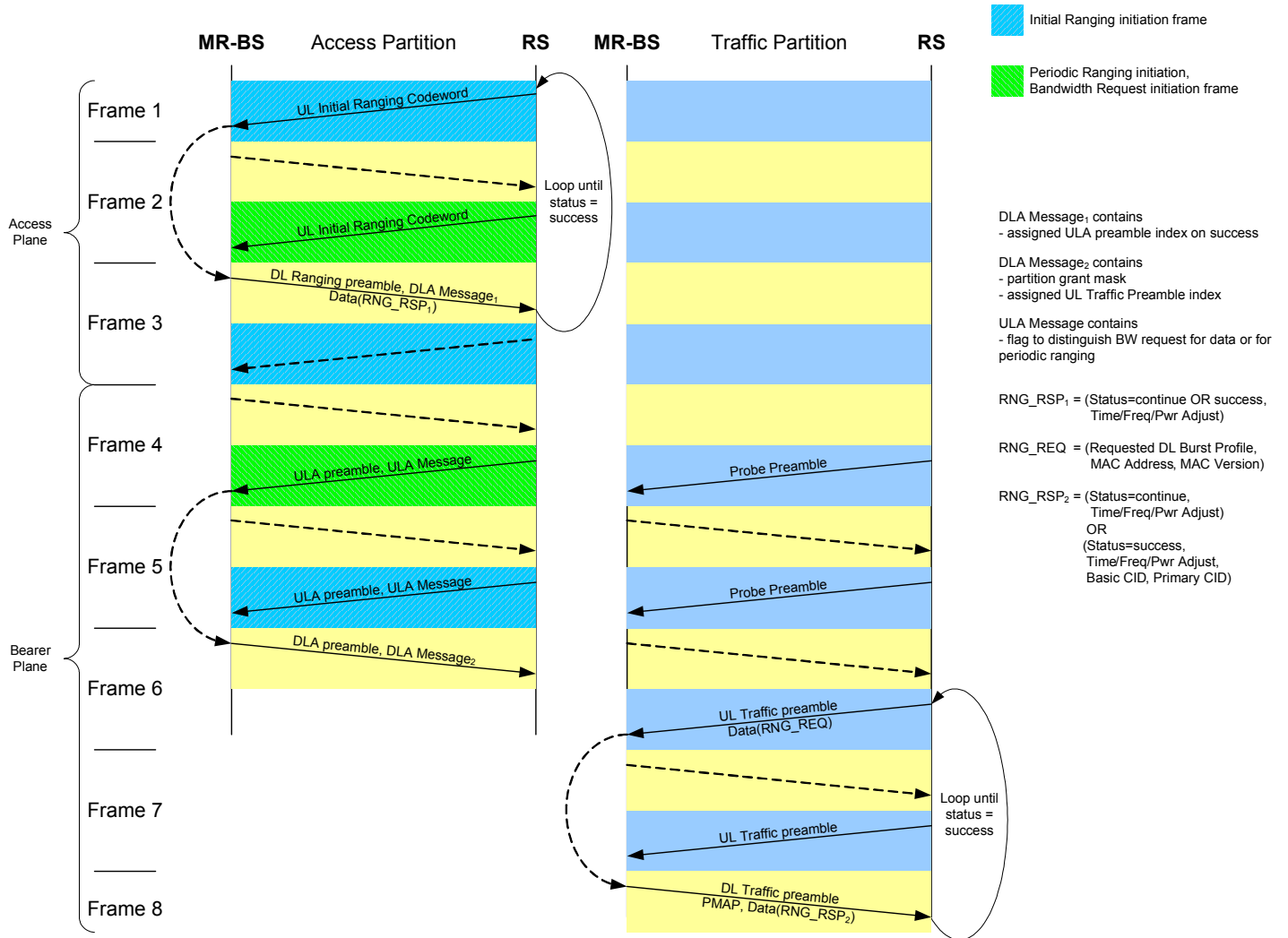

Figure xxx: Initial Ranging Message Sequence in AAS Relay Zone

Private MAP (PMAP)

The PMAP is used to grant bandwidth and provide HARQ control signaling on a burst basis. It is always transmitted as QPSK 1/2 rate and is anchored within the burst (it is transmitted as the first AMC slot within the lowest numbered partition of a burst). The following table defines the AAS_PMAP Message structure:

Table 1: AAS_PMAP Message Structure

PMAP Component	Bits	Reps	Slot	Comment
----------------	------	------	------	---------

AAS_PMAP_Message {				
PB_Ctl_0_Partition_Id	5	1		Partition id for control_0 structure
PB_Ctl_0_Burst_Id	2	1		Burst id for control_0 structure
UL_HARQ_Ack/Nack	1	1		1=Ack, 0=Nack
PB_Ctl_1_Partition_Id	5	1		Partition id for control_1 structure
PB_Ctl_1_Burst_Id	2	1		Burst id for control_1 structure
DL_HARQ_re-tx_indication	1	1		0=new frame, 1=frame n-2 retransmission
PB_Ctl_2_Partition_Id	5	1		Partition id for control_2 structure
DIUC	3	1		DL MCS level
PB_Ctl_2_Burst_Id	2	1		Burst id for control_2 structure
UIUC_Offset	2	1		UL MCS offset from the DIUC index
UL_Range_Adjust	2	1		Range Adjustment encode
UL_Frequency_Adjust	2	1		Frequency Adjustment encode
UL_Partition_Power_Adjust	8	1		1 bit per partition (CVSD)
CRC	8	1		CRC-8
}				
Total_PMAP_Bits	96		2	

1) **Partition/Burst Control** (7 bit encode) – The partition/burst control encode is described in Table 2 below:

Table 2: Partition/Burst Control encode¹

5 bit value	2 bit encode value	Description
0-23	0-3 (burst index)	Probe, Open or Maintain (p,o,m) the partition indexed by the 5 bit value in the burst indexed by the 2 bit encode value.
24	0-3 (partition index)	Close Partition in the 4 partition range 0-3 indexed by the 2 bit encode value
25	0-3 (partition index)	Close Partition in the 4 partition range 4-7 indexed by the 2 bit encode value
26	0-3 (partition index)	Close Partition in the 4 partition range 8-11 indexed by the 2 bit encode value
27	0-3 (partition index)	Close Partition in the 4 partition range 12-15 indexed by the 2 bit encode value
28	0-3 (partition index)	Close Partition in the 4 partition range 16-19 indexed by the 2 bit encode value
29	0-3 (partition index)	Close Partition in the 4 partition range 20-23 indexed by the 2 bit encode value
30	0-3 (burst index)	Close all partitions in burst using 2 bit encode as burst number
31	0-3	0: Fast power control for MCS increase (affects all partitions in current burst) 1-3: <i>Reserved</i>

A special encode for value 31 is used when there is an UL MCS increase. In this case there must be power increase step sizes of approximately 1.8 dB to ensure we can increase power over 3dB within two frames.

- 2) **UL Time (Range) Adjust** (2 bit encode) - There will be a configurable delta (d_t) for the time adjustment. A step size of $d_t = 0.714$ us is proposed. 0.714 us corresponds to 4 samples at a 5.6 MHz sample rate. In 802.16, 4 samples corresponds to a “PS”. The frequency adjustment encode is described in Table 3 below:

Table 3: UL Range (Time) Adjustment Encoding

Encoded bits	Time Delay @ BS	SS UL Adjustment
00	$t_e < -\delta_t$	Delay
01	$-\delta_t \leq t_e < 0$	Delay
10	$0 \leq t_e < \delta_t$	Advance
11	$\delta_t \leq t_e$	Advance

- 3) **UL Frequency Adjust** (2 bit encode) – There will be a configurable delta (d_f) for the frequency adjustment. The frequency adjustment encode is described in Table 4 below:

Table 4: UL Frequency Adjustment Encoding

Encoded bits	Frequency Error @ BS	SS UL Adjustment
00	$f_e < -d_f$	increase frequency
01	$-d_f \leq f_e < 0$	increase frequency
10	$0 \leq f_e < d_f$	decrease frequency
11	$d_f \leq f_e$	decrease frequency

- 4) **UL Power Adjust** (8 bit encode) – The power adjust is a 1-bit CVSD encode per available partition in a burst.

CQICH Signaling

The CQICH is always allocated as the last symbol of a frame for any partition that is allocated to an RS. There is no need for an allocation IE or control IE to allocate resources, or manage configuration. The configuration is implicit according to the sections below.

CQICH mapper and demodulator

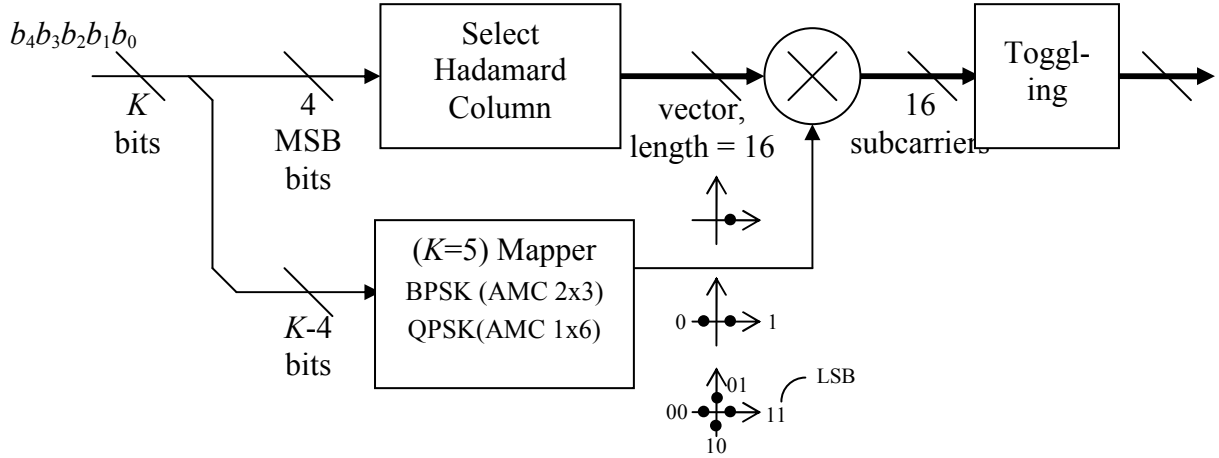

Figure 1. Block diagram of CQICH mapper

We will use $K = 5$ bits. The constellation is BPSK for AMC permutation 2x3 and QPSK for AMC permutation 1x6. The constellation amplitude is unity; no boosting. b_4 is the MSB.

The toggling vector is applied per partition, which is described as:

$$CQICH_Toggle_Vector = [111-1111-1-1-11-111-11]$$

in which the k -th element (from the leftmost) corresponds to the k -th bit (from the lowest subcarrier) of the coded CQICH sequence.

The Hadamard matrix is as follows. The CQICH mapper's 4-bit input value defines which of the column vectors will be selected.

1	1	1	1	1	1	1	1	1	1	1	1	1	1	1	1
1	-1	1	-1	1	-1	1	-1	1	-1	1	-1	1	-1	1	-1
1	1	-1	-1	1	1	-1	-1	1	1	-1	-1	1	1	-1	-1
1	-1	-1	1	1	-1	-1	1	1	-1	-1	1	1	-1	-1	1
1	1	1	1	-1	-1	-1	-1	1	1	1	1	-1	-1	-1	-1
1	-1	1	-1	-1	1	1	-1	1	-1	1	-1	-1	-1	1	1
1	1	-1	-1	-1	-1	-1	1	1	1	-1	-1	-1	-1	1	1
1	-1	-1	1	-1	1	1	-1	1	-1	-1	1	-1	1	1	-1
1	1	1	1	1	1	1	1	-1	-1	-1	-1	-1	-1	-1	-1
1	-1	1	-1	1	-1	1	-1	-1	1	-1	1	-1	1	-1	1
1	1	-1	-1	1	1	-1	-1	-1	-1	1	1	-1	-1	1	1
1	-1	-1	1	1	-1	-1	1	-1	1	1	-1	-1	1	1	-1
1	1	1	1	-1	-1	-1	-1	-1	-1	-1	-1	1	1	1	1
1	-1	1	-1	-1	1	-1	1	-1	1	-1	1	1	-1	1	-1
1	1	-1	-1	-1	-1	-1	1	1	-1	-1	1	1	1	-1	-1
1	-1	-1	1	-1	1	1	-1	-1	1	1	-1	1	-1	-1	1

UL Tx headroom report

This field describes the difference between the maximum permissible power and the current RS UL transmit power. The current UL transmit power is for all of the partitions and is the greater one of the two antennas.

For a burst with only one partition

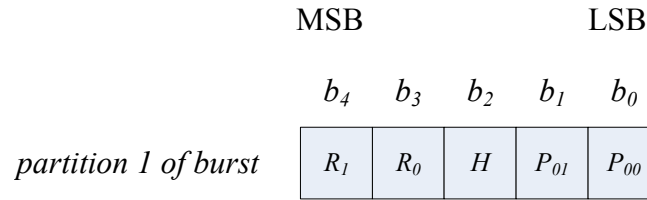

Figure 2. CQICH bit allocation of 1 partition sub-burst

Note: P_{ij} is defined as power control for each partition, and subscript i denotes partition index, and subscript j denotes power control bit index; H is defined as HARQ acknowledge bit; and R_m is defined as headroom report bits.

Table 5. For a burst with only 1 partition

$R_1 R_0$	Description
00	There is no headroom and this partition is the most expensive partition (MEP) among all open partitions
01	There is no headroom and this partition is not the MEP among all open partitions taking into account partitions in other bursts.
10	There is enough headroom to open 1 additional partition or increase the MCS
11	There is enough headroom to open 2 partitions or increase the MCS

If multiple bursts are open, only one partition in one of the bursts will be indicated as the MEP if the RS is out of headroom.

In a multiple bursts case, the recommendation for each burst can be implemented simultaneously by the BS. For example, if burst 0 says OK to add 2 partitions, and burst 1 says OK to add 1 partition, the BS may choose to add 0 to 3 partitions.

H is the DL HARQ bit; 1=ACK, 0=NACK.

For a burst with two partitions

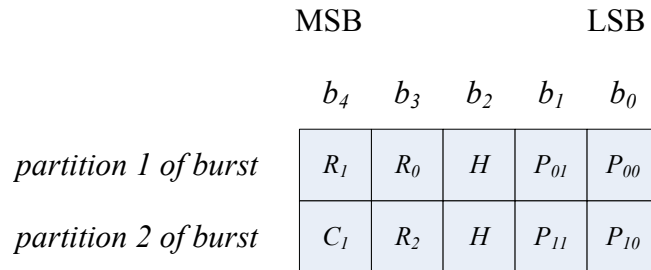

Figure 3. CQICH bit allocation for 2 partition sub-burst

Table 6. For a burst with 2 to 4 partitions

$R_2R_1R_0$	Description
000	There is no headroom, and 1 st partition in the burst is the MEP
001	There is no headroom, and 2 nd partition in the burst is the MEP
010	There is no headroom, and 3 rd partition in the burst is the MEP
011	There is no headroom, and 4 th partition in the burst is the MEP
100	Not enough headroom to increase MCS nor open new partition, and no partition in the burst is the MEP
101	Enough headroom to open 1 partition
110	Enough headroom to open 2 partitions
111	Enough headroom to increase MCS of the burst

Bit C_1 is used for even parity check across the CQICH bits, except the HARQ bit of the 2nd partition, of the 2 partitions, such as:

$$R_0 \oplus R_1 \oplus R_2 \oplus H \oplus P_{00} \oplus P_{01} \oplus P_{10} \oplus P_{11} \oplus C_1 = 0 \quad (1)$$

At the base station, if the parity check fails or either of the HARQ bits on two partitions are equal to NACK, we assume a NACK was transmitted. During transmission, the HARQ bit of the second partition is identical to the HARQ bit of the first partition.

When there are two partitions are open, the two partitions can be placed in either one burst or two bursts. Here we recommend using one burst with two partitions. By doing this, we can reduce the PMAP overhead, and add parity check and HARQ bit repetition.

For a burst with 3 partitions

	MSB			LSB	
	b_4	b_3	b_2	b_1	b_0
<i>partition 1 of burst</i>	C_0	R_0	H	P_{01}	P_{00}
<i>partition 2 of burst</i>	C_1	R_1	H	P_{11}	P_{10}
<i>partition 3 of burst</i>	C_2	R_2	H	P_{21}	P_{20}

Figure 4. CQICH bit allocation for 3 partition sub-burst

Bit C_i is used for even parity check across the CQICH bits on each partition, such as:

$$R_i \oplus H \oplus P_{i0} \oplus P_{i1} \oplus C_i = 0 \quad (2)$$

At base station, we assume that a HARQ NACK was transmitted if any of the following conditions are true:

- No partition passes parity check.
- At least one partition passes parity check, and the number of partitions with a NACK is more than or equal to the number of partition with an ACK.

This rule also applies to a burst with more than 3 partitions.

For a burst with 4 partitions

	MSB		LSB		
	b_4	b_3	b_2	b_1	b_0
<i>partition 1 of burst</i>	C_0	R_0	H	P_{01}	P_{00}
<i>partition 2 of burst</i>	C_1	R_1	H	P_{11}	P_{10}
<i>partition 3 of burst</i>	C_2	R_2	H	P_{21}	P_{20}
<i>partition 4 of burst</i>	C_3	1	H	P_{31}	P_{30}

Figure 5. CQICH bit allocation for a 4 partition sub-burst.

The parity check bit for the first 3 partitions are defined as in (2).

The parity check bits for the 4th partition is defined as:

$$C_i \oplus 1 \oplus H \oplus P_{i1} \oplus P_{i0} = 0 \quad (3)$$

For a burst with more than 4 partitions

	MSB		LSB		
	b_4	b_3	b_2	b_1	b_0
<i>partition 1 of burst</i>	C_0	R_0	H	P_{01}	P_{00}
<i>partition 2 of burst</i>	C_1	R_1	H	P_{11}	P_{10}
<i>partition 3 of burst</i>	C_2	R_2	H	P_{21}	P_{20}
<i>partition 4 of burst</i>	C_3	R_3	H	P_{31}	P_{30}
<i>partition m of burst</i>	C_m	1	H	P_{m1}	P_{m0}

Figure 6. CQICH bit allocation for a sub-burst with more than 4 partitions (m=5, 6, 7, 8)

The parity check bit for the first 4 partitions are defined as in (2).

The parity check bit for other partitions are defined as in (3).

Table 7. For a burst with 5 to 8 partitions

$R_3R_2R_1R_0$	Description
0000	There is no headroom, and 1 st partition of the burst is the MEP
0001	There is no headroom, and 2 nd partition of the burst is the MEP
0010	There is no headroom, and 3 rd partition of the burst is the MEP
0011	There is no headroom, and 4 th partition of the burst is the MEP
0100	There is no headroom, and 5 th partition of the burst is the MEP
0101	There is no headroom, and 6 th partition of the burst is the MEP
0110	There is no headroom, and 7 th partition of the burst is the MEP
0111	There is no headroom, and 8 th partition of the burst is the MEP
1000	There is no enough headroom to increase MCS nor open a new partition.
1001	Enough headroom to open 1 partition
1010	Enough headroom to open 2 partitions
1011	Enough headroom to increase MCS of the burst
11xx	Not defined

Definition of power control bits

There are two power control bits in each CQICH. The definition is given in Table 8.

Table 8. DL Power Control Step Sizes

P_1P_0	DL_Power_Control	$e = \text{measured_snr} - \text{target_snr}$ (mW/mW)
0 0	Increase TX power a lot	$e < -G_{2a}$
0 1	Increase TX power a little	$-G_{2a} \leq e < 0$
1 0	Decrease TX power a little	$0 \leq e < G_{2a}$
1 1	Decrease TX power a lot	$G_{2a} \leq e$

The value of G_{2a} is determined by SNR measurement jitter.

Proposed Text Changes

Insert the following subclause 8.4.4.7.3.2.3.6:

8.4.4.7.2.3.6 AAS Relay Zone Messaging

The AAS-DS Private Map structure provides information for supporting bandwidth grant. AAS-DS Resource allocation utilizes the follow definitions:

- 4) Partition – a partition of frequency within the carrier channel. AAS-DS partitions utilize AMC slots and are therefore comprised of 1 or 2 bins as defined by the AMC subchannel permutation (1 bin x 6 symbols or 2 bins x 3 symbols). The partition is the smallest unit of allocation granularity within a burst for the AAS Relay Zone. Partitions are numbered with an index in ascending order based on frequency (starting with an index of 0). A partition allocation is a coupled resource allocation which is granted in both the DL subframe and UL subframe for each frame of allocation.
- 5) Burst – a burst is the unit resource allocation within the AAS zone. A burst is comprised of 1 to 8 partitions. The AAS zone can support 1 to 4 bursts per user. Bursts are defined to be HARQ enabled or disabled within the partition control structure described on section x.x.x.x.x.
- 6) Partition Control actions
 - a) Probe – a training preamble that allows the BS to unobtrusively determine interference characteristics between the probing users and current active users within a single partition of frequency.
 - b) Open – an allocation grant of the partition resource
 - c) Close – a de-allocation of the partition resource
 - d) Maintain – maintain the allocation of partition resource (used to maintain synchronization of partition resource allocation between the BS and RS since the partition controls are all delta state related.).

The initial ranging message sequence for an entering RS shows the migration from the Access partition utilizing the DLA for bandwidth grant and physical layer control to a traffic partition as part of a burst allocation where the PMAP is then used for bandwidth grant and physical layer control. The initial ranging message sequence for an RS entering the network in the AAS Relay zone is as follows:

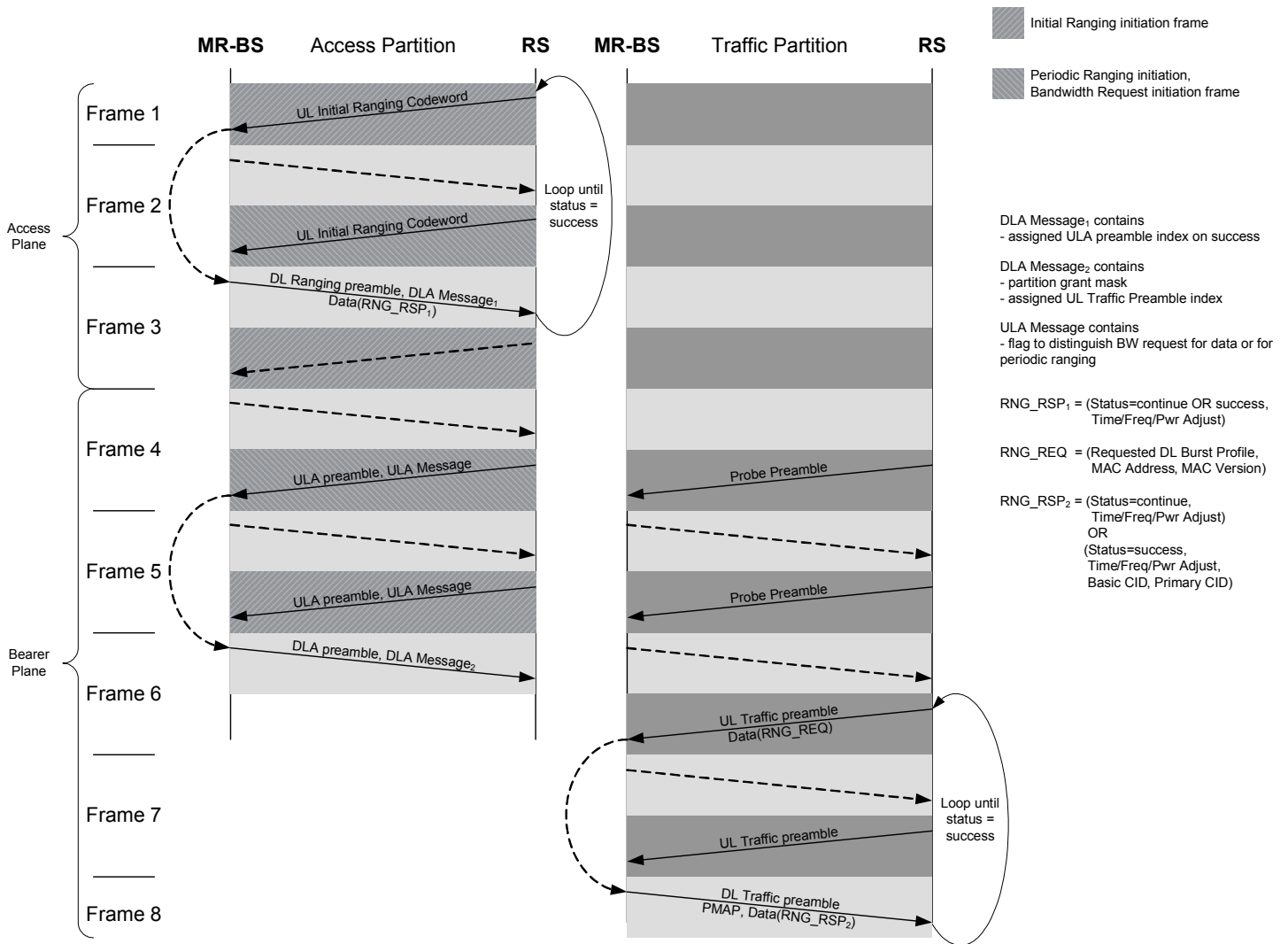

Figure xxx: Initial Ranging Message Sequence in AAS Relay Zone

8.4.4.7.2.3.6.1 Private MAP (PMAP) Message

The FLP provides code word assignments during initial ranging and provides bandwidth grant, codeword assignment, supportable MCS for UL/DL, and range(time)/frequency/power adjustment during the bandwidth grant exchange.

Insert Table 2xx (.16e)/Table 3xx (Rev2) as indicated:

Table xxx – AAS_PMAP Message

Syntax	Size	Notes
AAS_PMAP() {		
PB_Ctl_0_Partition_Id	5 bits	Partition id for control_0 structure
PB_Ctl_0_Burst_Id	2 bits	Burst id for control_0 structure
UL HARQ Ack/Nack	1 bit	1=Ack, 0=Nack
PB_Ctl_1_Partition_Id	5 bits	Partition id for control_1 structure
PB_Ctl_1_Burst_Id	2 bits	Burst id for control_1 structure
DL HARQ re-tx indication	1 bit	0=new frame, 1=frame n-2 retransmission
PB_Ctl_2_Partition_Id	5 bits	Partition id for control_2 structure
DIUC	3 bits	DL MCS level

PB Ctl 2 Burst Id	2 bits	Burst id for control_2 structure
UIUC Offset	2 bits	UL MCS offset from the DIUC index
UL Range Adjust	2 bits	Range Adjustment encode
UL Frequency Adjust	2 bits	Frequency Adjustment encode
UL Partition Power Adjust	8 bits	1 bit per partition (CVSD)
CRC	8 bits	CRC-8
}		

Insert the following parameter descriptions following Table 2xx (.16e)/Table 3xx (Rev2) as indicated:

Partition_Ctl_0_Partition_Id

5 bit Partition Id encode portion for the first of three partition control structures (Partition_Ctl_0) described in table xxx

Partition_Ctl_0_Burst_Id

2 bit Burst Id encode portion for the first of three partition control structures (Partition_Ctl_0) described in table xxx

UL HARQ Ack/Nack

Indicates whether frame n-2 UL was received successfully or not (1=Ack, 0=Nack)

Partition_Ctl_1_Partition_Id

5 bit Partition Id encode portion for the second of three partition control structures (Partition_Ctl_1) described in table xxx

Partition_Ctl_1_Burst_Id

2 bit Burst Id encode portion for the second of three partition control structures (Partition_Ctl_1) described in table xxx

DL HARQ re-tx indication

Indicates whether this DL burst is a retransmission or not. (0=new frame, 1=frame n-2 retransmission)

Partition_Ctl_2_Partition_Id

5 bit Partition Id encode portion for the third of three partition control structures (Partition_Ctl_2) described in table xxx

DIUC

DIUC

Partition_Ctl_2_Burst_Id

2 bit Burst Id encode portion for the third of three partition control structures (Partition_Ctl_2) described in table xxx

UIUC Offset

Offset from the DIUC

UL Range Adjust

Range Adjustment.

UL Frequency Adjust

Frequency adjustment

UL Partition Power Adjust

Power adjustment for the bearer partitions (up to 6 described in the partition grant control)

8.4.4.7.2.3.6.2 CQICH Signaling

The CQICH is always allocated as the last symbol of a frame for any partition that is allocated to an RS. There is no need for an allocation IE or control IE to allocate resources, or manage configuration. The configuration is implicit according to the sections below.

8.4.4.7.2.3.6.2.1 CQICH mapper

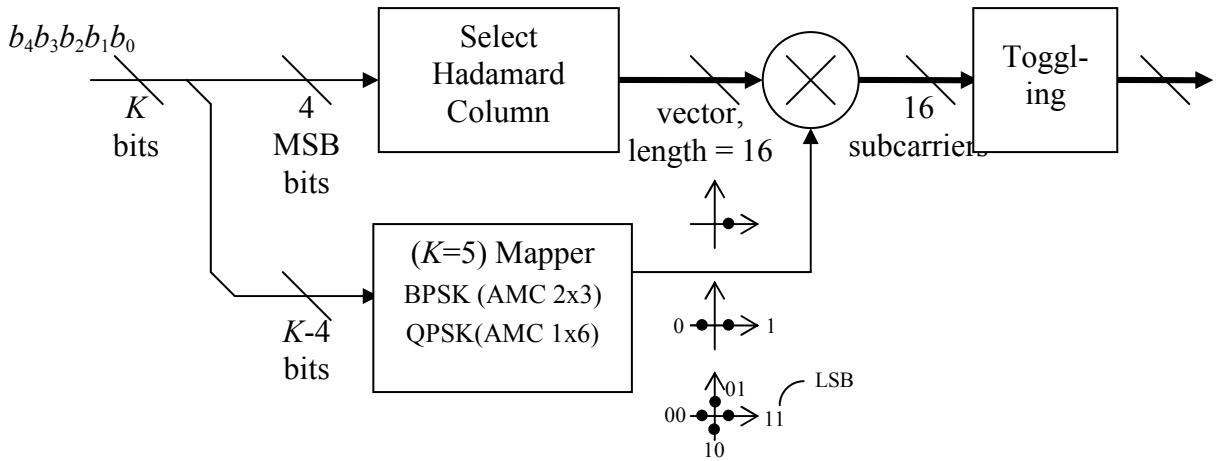

Figure xxx. Block diagram of CQICH mapper

We will use $K = 5$ bits. The constellation is BPSK for AMC permutation 2x3 and QPSK for AMC permutation 1x6. The constellation amplitude is unity; no boosting. b_4 is the MSB.

The toggling vector is applied per partition, which is described as:

$$CQICH_Toggle_Vector = [111-1111-1-1-11-111-11]$$

in which the k-th element (from the leftmost) corresponds to the k-th bit (from the lowest subcarrier) of the coded CQICH sequence.

The Hadamard matrix is as follows. The CQICH mapper's 4-bit input value defines which of the column vectors will be selected.

1	1	1	1	1	1	1	1	1	1	1	1	1	1	1	1
1	-1	1	-1	1	-1	1	-1	1	-1	1	-1	1	-1	1	-1
1	1	-1	-1	1	1	-1	-1	1	1	-1	-1	1	1	-1	-1
1	-1	-1	1	1	-1	-1	1	1	-1	-1	1	1	-1	-1	1
1	1	1	1	-1	-1	-1	-1	1	1	1	1	-1	-1	-1	-1
1	-1	1	-1	-1	1	-1	1	-1	1	-1	1	-1	-1	1	-1
1	1	-1	-1	-1	-1	1	1	1	1	-1	-1	-1	-1	1	1
1	-1	-1	1	-1	1	1	-1	1	-1	-1	1	-1	1	1	-1
1	1	1	1	1	1	1	1	1	-1	-1	-1	-1	-1	-1	-1
1	-1	1	-1	1	-1	1	-1	-1	1	-1	1	-1	1	-1	1
1	1	-1	-1	1	1	-1	-1	-1	-1	1	1	-1	-1	1	1
1	-1	-1	1	1	-1	-1	1	-1	1	1	-1	-1	1	1	-1
1	1	1	1	-1	-1	-1	-1	-1	-1	-1	-1	1	1	1	1
1	-1	1	-1	-1	1	-1	1	-1	1	-1	1	1	-1	1	-1
1	1	-1	-1	-1	-1	1	1	-1	-1	1	1	1	1	-1	-1
1	-1	-1	1	-1	1	1	-1	-1	1	1	-1	1	-1	-1	1

8.4.4.7.2.3.6.2.2 UL Tx headroom report

This field describes the difference between the maximum permissible power and the current RS UL transmit power. The current UL transmit power is for all of the partitions and is the greater one of the two antennas.

8.4.4.7.2.3.6.2.2.1 For a Burst with only one partition

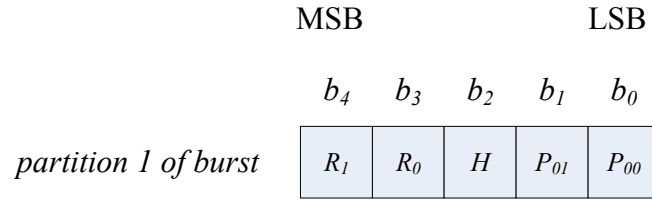

Figure xxx. CQICH bit allocation of 1 partition sub-burst

Note: P_{ij} is defined as power control for each partition, and subscript i denotes partition index, and subscript j denotes power control bit index; H is defined as HARQ acknowledge bit; and R_m is defined as headroom report bits.

Table xxx. For a burst with only 1 partition

$R_1 R_0$	Description
00	There is no headroom and this partition is the most expensive partition (MEP) among all open partitions
01	There is no headroom and this partition is not the MEP among all open partitions taking into account partitions in other bursts.
10	There is enough headroom to open 1 additional partition or increase the MCS
11	There is enough headroom to open 2 partitions or increase the MCS

If multiple bursts are open, only one partition in one of the bursts will be indicated as the MEP if the RS is out of headroom.

In a multiple bursts case, the recommendation for each burst can be implemented simultaneously by the BS. For example, if burst 0 says OK to add 2 partitions, and burst 1 says OK to add 1 partition, the BS may choose to add 0 to 3 partitions.

H is the DL HARQ bit; 1=ACK, 0=NACK.

8.4.4.7.2.3.6.2.2.2 For a burst with two partitions

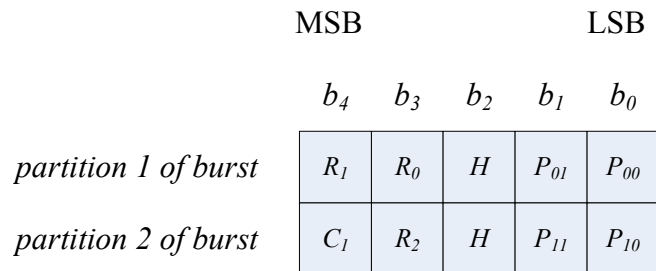

Figure xxx. CQICH bit allocation for 2 partition sub-burst

Table xxx. For a burst with 2 to 4 partitions

$R_2 R_1 R_0$	Description
000	There is no headroom, and 1 st partition in the burst is the MEP
001	There is no headroom, and 2 nd partition in the burst is the MEP

010	There is no headroom, and 3 rd partition in the burst is the MEP
011	There is no headroom, and 4 th partition in the burst is the MEP
100	Not enough headroom to increase MCS nor open new partition, and no partition in the burst is the MEP
101	Enough headroom to open 1 partition
110	Enough headroom to open 2 partitions
111	Enough headroom to increase MCS of the burst

Bit C_1 is used for even parity check across the CQICH bits, except the HARQ bit of the 2nd partition, of the 2 partitions, such as:

$$R_0 \oplus R_1 \oplus R_2 \oplus H \oplus P_{00} \oplus P_{01} \oplus P_{10} \oplus P_{11} \oplus C_1 = 0 \quad (4)$$

At the base station, if the parity check fails or either of the HARQ bits on two partitions are equal to NACK, we assume a NACK was transmitted. During transmission, the HARQ bit of the second partition is identical to the HARQ bit of the first partition.

When there are two partitions are open, the two partitions can be placed in either one burst or two bursts. Here we recommend using one burst with two partitions. By doing this, we can reduce the PMAP overhead, and add parity check and HARQ bit repetition.

8.4.4.7.2.3.6.2.2.3 For a burst with 3 partitions

	MSB		LSB		
	b_4	b_3	b_2	b_1	b_0
<i>partition 1 of burst</i>	C_0	R_0	H	P_{01}	P_{00}
<i>partition 2 of burst</i>	C_1	R_1	H	P_{11}	P_{10}
<i>partition 3 of burst</i>	C_2	R_2	H	P_{21}	P_{20}

Figure 7. CQICH bit allocation for 3 partition sub-burst

Bit C_i is used for even parity check across the CQICH bits on each partition, such as:

$$R_i \oplus H \oplus P_{i0} \oplus P_{i1} \oplus C_i = 0 \quad (5)$$

At base station, we assume that a HARQ NACK was transmitted if any of the following conditions are true:

- No partition passes parity check.
- At least one partition passes parity check, and the number of partitions with a NACK is more than or equal to the number of partition with an ACK.

This rule also applies to a burst with more than 3 partitions.

8.4.4.7.2.3.6.2.2.4 For a burst with 4 partitions

	MSB		LSB		
	b_4	b_3	b_2	b_1	b_0
<i>partition 1 of burst</i>	C_0	R_0	H	P_{01}	P_{00}
<i>partition 2 of burst</i>	C_1	R_1	H	P_{11}	P_{10}
<i>partition 3 of burst</i>	C_2	R_2	H	P_{21}	P_{20}
<i>partition 4 of burst</i>	C_3	1	H	P_{31}	P_{30}

Figure xxx. CQICH bit allocation for a 4 partition sub-burst.

The parity check bit for the first 3 partitions are defined as in (2).

The parity check bits for the 4th partition is defined as:

$$C_i \oplus 1 \oplus H \oplus P_{i1} \oplus P_{i0} = 0 \quad (6)$$

8.4.4.7.2.3.6.2.2.5 For a burst with more than 4 partitions

	MSB		LSB		
	b_4	b_3	b_2	b_1	b_0
<i>partition 1 of burst</i>	C_0	R_0	H	P_{01}	P_{00}
<i>partition 2 of burst</i>	C_1	R_1	H	P_{11}	P_{10}
<i>partition 3 of burst</i>	C_2	R_2	H	P_{21}	P_{20}
<i>partition 4 of burst</i>	C_3	R_3	H	P_{31}	P_{30}
<i>partition m of burst</i>	C_m	1	H	P_{m1}	P_{m0}

Figure xxx. CQICH bit allocation for a sub-burst with more than 4 partitions (m=5, 6, 7, 8)

The parity check bit for the first 4 partitions are defined as in (2).

The parity check bit for other partitions are defined as in (3).

Table xxx. For a burst with 5 to 8 partitions

$R_3R_2R_1R_0$	Description
0000	There is no headroom, and 1 st partition of the burst is the MEP
0001	There is no headroom, and 2 nd partition of the burst is the MEP
0010	There is no headroom, and 3 rd partition of the burst is the MEP
0011	There is no headroom, and 4 th partition of the burst is the MEP
0100	There is no headroom, and 5 th partition of the burst is the MEP
0101	There is no headroom, and 6 th partition of the burst is the MEP
0110	There is no headroom, and 7 th partition of the burst is the MEP
0111	There is no headroom, and 8 th partition of the burst is the MEP
1000	There is no enough headroom to increase MCS nor open a new partition.
1001	Enough headroom to open 1 partition
1010	Enough headroom to open 2 partitions
1011	Enough headroom to increase MCS of the burst
11xx	Not defined

8.4.4.7.2.3.6.2.3 Definition of power control bits

There are two power control bits in each CQICH. The definition is given in Table 8 below.

Table xxx DL Power Control Step Sizes

P_1P_0	DL_Power_Control	$e = \text{measured_snr} - \text{target_snr}$ (mW/mW)
0 0	Increase TX power a lot	$e < -G_{2a}$
0 1	Increase TX power a little	$-G_{2a} \leq e < 0$
1 0	Decrease TX power a little	$0 \leq e < G_{2a}$
1 1	Decrease TX power a lot	$G_{2a} \leq e$

The value of G_{2a} is determined by SNR measurement jitter.