

Project	IEEE 802.16 Broadband Wireless Access Working Group < http://ieee802.org/16 >	
Title	Coexistence Recommended Practice – working document version 1.3	
Date Submitted	2002-05-10	
Source(s)	Philip Whitehead Radiant Networks PLC The Mansion, Chesterford park Little Chesterford, Essex, CB10 1XL UK	Voice: 01799 533600 Fax: 01799 533601 mailto:pw@radiantnetworks.co.uk
Re:	Amendments to Recommended Practice for Coexistence of Fixed BWA Systems IEEE802.16.2	
Abstract	This is a task group 2 working document containing draft material accepted for inclusion in the amended Recommended Practice for Coexistence of Fixed Broadband Wireless Access Systems. It is intended as a placeholder for accepted results and is not a formal WG draft document. The current version contains all results prior to session #19.	
Purpose	Placeholder for accepted contributions and simulation results	
Notice	This document has been prepared to assist IEEE 802.16. It is offered as a basis for discussion and is not binding on the contributing individual(s) or organization(s). The material in this document is subject to change in form and content after further study. The contributor(s) reserve(s) the right to add, amend or withdraw material contained herein.	
Release	The contributor grants a free, irrevocable license to the IEEE to incorporate material contained in this contribution, and any modifications thereof, in the creation of an IEEE Standards publication; to copyright in the IEEE's name any IEEE Standards publication even though it may include portions of this contribution; and at the IEEE's sole discretion to permit others to reproduce in whole or in part the resulting IEEE Standards publication. The contributor also acknowledges and accepts that this contribution may be made public by IEEE 802.16.	
Patent Policy and Procedures	<p>The contributor is familiar with the IEEE 802.16 Patent Policy and Procedures (Version 1.0) <http://ieee802.org/16/ipr/patents/policy.html>, including the statement “IEEE standards may include the known use of patent(s), including patent applications, if there is technical justification in the opinion of the standards-developing committee and provided the IEEE receives assurance from the patent holder that it will license applicants under reasonable terms and conditions for the purpose of implementing the standard.”</p> <p>Early disclosure to the Working Group of patent information that might be relevant to the standard is essential to reduce the possibility for delays in the development process and increase the likelihood that the draft publication will be approved for publication. Please notify the Chair <mailto:r.b.marks@ieee.org> as early as possible, in written or electronic form, of any patents (granted or under application) that may cover technology that is under consideration by or has been approved by IEEE 802.16. The Chair will disclose this notification via the IEEE 802.16 web site <http://ieee802.org/16/ipr/patents/notices>.</p>	

Coexistence Recommended Practice – working document version 1.3

[This WORD version of the amended document is provided for convenient reading and editing by WG members It is to be read in conjunction with the Framemaker/ pdf version of the published information. Editorial instructions for the IEEE editor show the proposed amendments to the published document and only these are to be considered. The inclusion of original text and graphics is otherwise only for convenience of reading.]

[The title page and IEEE introductory pages have been omitted from this version of the working document]

IEEE Draft Recommended Practice for Local and Metropolitan area networks

Coexistence of Fixed Broadband Wireless Access Systems

[review following text]

Abstract: This document amends IEEE recommended practice 802.16.2-2001 by adding guidelines for minimizing interference in fixed broadband wireless access (BWA) systems operating in the frequency range 2 – 11 GHz and by adding guidelines for coexistence with point to point link systems operating in the frequency range 23.5 to 43.5 GHz. It analyzes appropriate additional coexistence scenarios and provides guidance for system design, deployment, coordination and frequency usage.

Keywords: coexistence, fixed broadband wireless access (FBWA), interference, local multipoint distribution service (LMDS), millimeter wave, multipoint, point-to-multipoint, radio, wireless metropolitan area network (WirelessMANTM) standard

Editor's Notes

1. The task group editor's notes are highlighted in yellow and are in brackets []. Draft text for review is highlighted in yellow.
2. Editorial instructions for the IEEE editor are in red text.
3. The following interpretation to be used to revise the text in the existing document: Subsection 6.1.3, Out-of-block unwanted emissions of the Recommended Practice for Coexistence of Fixed Broadband Wireless Access Systems relates to out-of-block unwanted emissions. Figure 7 provides an example application of out-of-block unwanted emission limits. The transmitter spectrum shown in the figure is an example of a typical actual spectrum for one possible channel bandwidth. It shows the relationship between the placement of the example carrier and the block edge mask, so as to meet the recommended out-of-blocks limits.

It is not an emission mask and there is no intention to imply the use of any particular mask. The system designer is free to choose the levels and placement of carrier frequencies in order to meet the recommended out-of-block emission limits.
4. The definition of B0 is to be reviewed and text revised, if necessary.
5. Proposed draft revisions to the text of the published document (to bring it up to date) are to be included in part1
6. A draft record of archived documents is to be added to the document
7. The introduction and related pages, together with the list of participants are to be added later. These precede the table of contents and the main text.
8. Add definition of what we mean by coexistence (see paper DRAFT 02072r0P802-15_TG2, submitted at St Louis meeting)

Table of Contents

OVERVIEW OF RECOMMENDED PRACTICE 6

SCOPE OF RECOMMENDED PRACTICE 6

NORMATIVE REFERENCES [TO BE REVISED] 7

DEFINITIONS AND ABBREVIATIONS [TO BE UPDATED] 7

 DEFINITIONS 7

 ABBREVIATIONS 9

PART 1 COEXISTENCE OF FIXED BROADBAND WIRELESS ACCESS SYSTEMS OPERATING IN THE FREQUENCY RANGE 23.5 – 43.5 GHZ 12

SCOPE OF PART 1 12

 SUMMARY OF FIXED BWA COEXISTENCE RECOMMENDATIONS AND GUIDELINES 12

Document philosophy [revise heading] 12

Recommendations 13

Suggested guidelines for geographical and frequency spacing 16

 SYSTEM OVERVIEW 17

System architecture 18

System components 19

Medium Overview 19

 EQUIPMENT DESIGN PARAMETERS 19

Transmitter design parameters 20

Receiver design parameters 20

 DEPLOYMENT AND COORDINATION 20

Co frequency, adjacent area 20

Same area/ adjacent frequency 20

Use of power spectral flux density (psfd) as a coexistence metric 20

Deployment procedure 20

 INTERFERENCE AND PROPAGATION EVALUATION/ EXAMPLES OF COEXISTENCE IN A PMP ENVIRONMENT 20

Guidelines for geographical and frequency spacing between fixed BWA systems 20

 MITIGATION TECHNIQUES 20

 ANNEXES A TO F 20

PART 2. COEXISTENCE OF FIXED BROADBAND WIRELESS ACCESS SYSTEMS OPERATING IN THE FREQUENCY RANGE 23.5 – 43.5 GHZ WITH POINT- TO- POINT LINKS, SHARING THE SAME FREQUENCY BAND. 22

[Overview of section] Scope of Part 2 22

[SCOPE STATEMENT (SUMMARY OF WHAT SCENARIOS HAVE BEEN STUDIED – DERIVED FROM PAR)] DELETE? ... 22

 RECOMMENDATIONS AND GUIDELINES, INCLUDING INDICATIVE GEOGRAPHICAL AND PHYSICAL SPACING BETWEEN SYSTEMS 23

Recommendations 23

Suggested guidelines for geographical and frequency spacing 26

 SYSTEM OVERVIEW (INTERFERER AND VICTIM SYSTEMS) 27

Interference scenario 1: multiple point to point links in a frequency block 27

Interference scenario 2: individually licensed links 27

<i>System parameters assumed in the simulations</i>	27
<i>Typical antenna characteristics</i>	30
<i>Interference Scenarios</i>	30
<i>Equipment design parameters</i>	31
<i>Antenna parameters</i>	31
<i>Deployment and coordination</i>	31
<i>Description of Interference Evaluation/ example scenarios</i>	31
MITIGATION TECHNIQUES	36
<i>Impact of buildings on Mesh/PP to PMP co-channel interference</i>	36
<i>Simulation Methodology</i>	36
<i>Simulation Results</i>	37
<i>Conclusions</i>	38
ANNEX 2A (INFORMATIVE)	38
TEST AND MEASUREMENT/ HARDWARE PARAMETER SUMMARY	39
ANNEX 2B (INFORMATIVE)	39
PSFD CALCULATIONS	39
ANNEX2C (INFORMATIVE)	39
DESCRIPTION OF CALCULATIONS AND SIMULATION METHODS	39
PART 3: COEXISTENCE OF FIXED BROADBAND WIRELESS ACCESS SYSTEMS OPERATING IN FREQUENCY RANGE 1; 2-11 GHZ	39
OVERVIEW OF SECTION	39
SCOPE STATEMENT (SUMMARY OF WHAT SCENARIOS HAVE BEEN STUDIED – DERIVED FROM PAR)	39
<i>Document philosophy [revise heading]</i>	40
RECOMMENDATIONS AND GUIDELINES, INCLUDING INDICATIVE GEOGRAPHICAL AND PHYSICAL SPACING BETWEEN SYSTEMS	41
<i>Recommendations</i>	41
<i>Suggested guidelines for geographical and frequency spacing</i>	44
SYSTEM OVERVIEW	44
<i>System architecture</i>	45
<i>System components</i>	46
SYSTEM DESCRIPTION (INTERFERER AND VICTIM SYSTEMS)	46
<i>Description of system interference scenarios</i>	46
<i>System parameters assumed in the simulations</i>	46
<i>Typical antenna characteristics</i>	50
<i>Medium Overview</i>	50
EQUIPMENT DESIGN PARAMETERS	51
<i>Transmitter design parameters</i>	51
<i>Receiver design parameters</i>	51
DEPLOYMENT AND COORDINATION	51
<i>Co frequency, adjacent area</i>	51
<i>Same area/ adjacent frequency</i>	51
<i>Use of power spectral flux density (psfd) as a coexistence metric</i>	51
<i>Deployment procedure</i>	51
INTERFERENCE AND PROPAGATION EVALUATION/ EXAMPLES OF COEXISTENCE IN A PMP ENVIRONMENT	52

<i>Guidelines for geographical and frequency spacing between fixed BWA systems</i>	52
MITIGATION TECHNIQUES	54
ANNEX 3A	54
TEST AND MEASUREMENT/ HARDWARE PARAMETER SUMMARY	54
ANNEX 3B	54
POWER SPECTRAL FLUX DENSITY (PSFD) CALCULATIONS	54
ANNEX 3C	54
DESCRIPTION OF CALCULATIONS AND SIMULATION METHODS	54
DESCRIPTION OF SIMULATIONS – 2.5 GHZ	54
<i>Methodology</i>	54
<i>Outline results from each simulation</i>	54
DESCRIPTION OF SIMULATIONS – 3.5 GHZ	54
<i>Methodology</i>	54
<i>Outline results from each simulation</i>	54
DESCRIPTION OF SIMULATIONS – 10.5 GHZ	54
ANNEX 3D	55
WORK OF OTHER BODIES	55
ANNEX 3E	55
UK RADIOCOMMUNICATIONS AGENCY COORDINATION PROCESS	55
ANNEX 3F	55
INDUSTRY CANADA COORDINATION PROCESS	55
ANNEX [] BIBLIOGRAPHY OF REFERENCES TO COMPLETE SIMULATION ANALYSIS	56
SIMULATIONS AND RELATED DOCUMENTS USED IN THE COMPILATION OF PART 1.....	56
SIMULATIONS AND RELATED DOCUMENTS USED IN THE COMPILATION OF PART 2.....	56
SIMULATIONS AND RELATED DOCUMENTS USED IN THE COMPILATION OF PART 3.....	57
OTHER ISSUES (FOR INTEGRATION INTO MAIN TEXT)	60
DOCUMENT HISTORY	60

Editorial Instruction: Delete the existing Overview and replace with the following text:

Overview of Recommended Practice

This document provides recommended practice for the design and coordinated deployment of fixed Broadband Wireless Access (BWA) systems to control interference and promote coexistence. This Recommended Practice is divided into three parts

- Part 1 deals with coexistence of FBWA systems in the frequency range 23.5 –43.5 GHz.
- Part 2 deals with coexistence issues between point-to-point link systems and FBWA systems in the frequency range 23.5 3.5 GHz.
- Part 3 deals with coexistence of FBWA systems in the frequency range 2-11 GHz

[It may be worth producing a general section preceding the three main parts. This would contain common material, mainly extracted from part 1. However, this creates more editing and it may be satisfactory just to repeat some material, thus making each part substantially self – contained]

[review following slightly amended text from existing document]

Each part includes nine [check] clauses. Clause 1 of each part provides the scope of the Recommended Practice. Clause 2 lists references to other standards that are useful in applying this Recommended Practice. Clause 3 provides definitions and abbreviations that are either not found in other standards or have been modified for use with this Recommended Practice. Clause 4 provides a summary of fixed BWA coexistence recommendations and guidelines. Clause 5 provides an overview of fixed BWA systems including system architecture and medium overview. Clause 6 deals with equipment design parameters, including radiated power, spectral masks and antenna patterns, and includes limits for both in-band and out-of-band fixed BWA system emissions. Also included in Clause 6 are recommended tolerance levels for certain receiver parameters, including noise floor degradation and blocking performance, for interference received from other fixed BWA systems as well as from other systems. Clause 7 provides the methodology to be used in the deployment and coordination of fixed BWA systems, including band plans, separation distances, and power spectral flux density limits to facilitate coordination and enable successful deployment of fixed BWA systems with tolerable interference. Clause 8 consists of interference and propagation evaluation examples of coexistence in a point-to-multipoint (PMP) environment, indicating some of the models, simulations and analyses used in the preparation of this Recommended Practice. Clause 9 describes some of the mitigation techniques that could be employed in case of co-channel interference between systems operating in adjacent areas or in case of undesired signals caused by natural phenomena and other unintentional sources.

Editorial Instruction: Delete the existing Scope and replace with the following text:

Scope of Recommended Practice

The intent of this document is to define a set of consistent design and deployment recommendations that promote coexistence for fixed BWA systems and for point-to-point systems that share the same bands. The recommendations have been developed and substantiated by analyses and simulations specific to the deployment and propagation environment appropriate to terrestrial fixed BWA intersystem interference experienced between operators licensed for fixed BWA and operators of point-to-point link systems sharing the same bands. These

recommendations, if followed by manufacturers and operators, will facilitate a wide range of equipment to coexist in a shared environment with acceptable mutual interference. The scope of this Recommended Practice includes the examination of interference between systems deployed across geographic boundaries in the same frequency blocks and systems deployed in the same geographic area in adjacent frequency blocks. This document emphasizes coexistence practices for multipoint systems with a variety of architectures and for point-to-point systems, where these share the same frequency bands as the multipoint systems. This Recommended Practice does not cover coexistence issues due to intra-system frequency reuse within the operator's authorized band, and it does not consider the impact of interference created by fixed BWA systems on satellite systems. This document is not intended to be a replacement for applicable regulations, which would take precedence.

Normative References [to be revised]

This Recommended Practice shall be used in conjunction with the following:

ETSI EN 301 390 V1.1.1. (2000-12), Fixed Radio Systems; Point-to-Point and Point-to-Multipoint Systems; Spurious Emissions and Receiver Immunity at Equipment/Antenna Port of Digital Fixed Radio Systems. 1

IEEE P802.16/D3, Draft Standard for Local and Metropolitan Area Networks; Part 16: Standard Air Interface for Fixed Broadband Wireless Access Systems.

Recommendation ITU-R F.1509: Technical and Operational Requirements that Facilitate Sharing between Point-to-Multipoint Systems in the Fixed Service and the Inter-Satellite service in the band 25.25 - 27.5 GHz. 3

Definitions and Abbreviations [to be updated]

Definitions

[numbering?]

3.1.1 authorized band: The range of frequencies over which an operator is permitted to operate radio transmitters and receivers.

3.1.2 automatic transmit power control (ATPC): A technique used in BWA systems to adaptively adjust the transmit power of a transmitter to maintain the received signal level within some desired range.

3.1.3 base station (BS): A generalized equipment set providing connectivity, management, and control of the subscriber station.

3.1.4 broadband: Having instantaneous bandwidths greater than around 1 MHz and supporting data rates greater than about 1.5 Mbit/s.

3.1.5 broadband wireless access (BWA): Wireless access in which the connection(s) capabilities are broadband.

3.1.6 cross-polar discrimination (XPD): The XPD of an antenna for a given direction is the difference in dB between the peak co-polarized gain of the antenna and the cross-polarized gain of the antenna in the given direction.

3.1.7 digital modulation: Digital modulation is the process of varying one or more parameters of a carrier wave (e.g., frequency, phase, amplitude, or combinations thereof) as a function of two or more finite and discrete states of a signal.

3.1.8 downlink: The direction from a base station to the subscriber station.

3.1.9 DS-3: A North American Common Carrier Multiplex level having a line rate of 44.736 Mbit/s.

3.1.10 fixed wireless access: Wireless access application in which the location of the SS and the BS are fixed in location.

3.1.11 frequency block: A contiguous portion of spectrum within a sub-band or frequency band, typically assigned to a single operator.

NOTE: A collection of frequency blocks may form a sub-band and/or a frequency band.

3.1.12 frequency division duplex (FDD): A duplex scheme in which uplink and downlink transmissions use different frequencies but are typically simultaneous.

3.1.13 Frequency Range 1: For purposes of this document, Frequency Range 1 refers to 10 - 23.5 GHz.

3.1.14 Frequency Range 2: For purposes of this document, Frequency Range 2 refers to 23.5 –4 3.5 GHz.

3.1.15 Frequency Range 3: For purposes of this document, Frequency Range 3 refers to 43.5 - 66 GHz.

3.1.16 frequency re-use: A technique for employing a set of frequencies in multiple, closely-spaced cells and/or sectors for the purpose of increasing network traffic capacity.

3.1.17 harmonized transmissions: The use, by multiple operators, of a compatible transmission plan so that the base stations from different operators can share an antenna site and minimize interference. For FDD systems, this implies that each operator's base station transmits in the same frequency sub-block (typically on a different channel) and that their terminals transmit in the corresponding paired sub-block. For TDD systems, harmonization implies frame, slot, and uplink/downlink synchronization.

3.1.18 intercell link: Intercell links interconnect two or more BS units, typically using wireless, fiber, or copper facilities.

3.1.19 mesh: A wireless network topology, known also as multipoint-to-multipoint, in which a number of subscriber stations within a geographic area are interconnected and can act as repeater stations. This allows a variety of routes between the core network and any subscriber station. Mesh systems do not have base stations in the conventional point-to-multipoint sense.

3.1.20 multicarrier system: A system using two or more carriers to provide service from a single transmitter.

3.1.21 multipoint (MP): A generic term for point-to-multipoint and multipoint-to-multipoint and variations or hybrids of these. Multipoint is a wireless topology in which a system provides service to multiple, 3.1.23 OC-3: One hierarchical level in the Synchronous Optical Network transmission standard. The line rate for this level is 155.52 Mbit/s.

3.1.24 occupied bandwidth (B_O): For a single carrier, B_O is the width of a frequency band such that, below its lower and above its upper frequency limits, the mean powers radiated are each equal to 0.5% of the total mean power radiated by a given emission. This implies that 99% of the total mean emitted power is within this band, and hence this bandwidth is also known as the 99% bandwidth. When a multicarrier transmission uses a common amplifier stage, the occupied bandwidth of this composite transmission is defined by the following relationship:

$$B_{OM} = 1/2 B_{OU} + 1/2 B_{OL} + (F_{OU} - F_{OL})$$

where:

B_{OM} = Occupied bandwidth of the multicarrier system

B_{OU} = Single-carrier Occupied Bandwidth of the lowermost sub-carrier

F_{OU} = Center frequency of the uppermost sub-carrier

F_{OL} = Center frequency of the lowermost sub-carrier

NOTE 1: This multicarrier definition will give a bandwidth which is slightly wider than the multicarrier 99% power bandwidth. For example, for six identical, adjacent carriers, B_O will contain 99.5% of the first carrier, 99.5% of the last carrier and 100% of the four middle carriers and therefore 99.8333% of total mean power.

NOTE 2: This definition applies to most analog and simple digital emissions (QAM, QPSK, etc.), but its applicability to other more complex modulation structures (e.g., OFDM, CDMA) is still to be determined.

3.1.25 out-of-block emissions (OOB emissions): Emissions from the edge of the authorized bandwidth up to 200% of the occupied bandwidth from the edge of the authorized bandwidth. These emissions occur both above and below the authorized bandwidth.

3.1.26 point-to-multipoint (PMP): In wireless systems, a topology wherein a base station simultaneously services multiple, geographically separated subscriber stations and each subscriber station is permanently associated with only one base station.

- 3.1.27 point-to-point: A topology in which a radio link is maintained between two stations.
- 3.1.28 power flux density (pfd): The radiated power flux per unit area.
- 3.1.29 power spectral flux density (psfd): The radiated power flux per unit bandwidth per unit area.
- 3.1.30 radiation pattern envelope (RPE): The RPE is a graph that represents the maximum sidelobe levels of an antenna over the specified band.
- 3.1.31 repeater station (RS): A station other than the BS that includes radio communication equipment facing two or more separate directions. Traffic received from one direction may be partly or wholly retransmitted in another direction. Traffic may also terminate and originate at the repeater station.
- 3.1.32 service area: A geographic area in which an operator is authorized to transmit.
- 3.1.33 spectrum disaggregation: Segregation of spectrum to permit several operators access to subportions of a licenseeTMs authorized band.
- 3.1.34 spurious emissions: Emissions greater than 200% of the occupied bandwidth from the edge of the authorized bandwidth. While this definition is specific to this Recommended Practice, International Telecommunications Union (ITU) Radio Regulation S.145 defines spurious emission as follows: Emission on a frequency or frequencies which are outside the necessary bandwidth and the level of which may be reduced without affecting the corresponding transmission of information. Spurious emissions include harmonic emissions, parasitic emissions, intermodulation products and frequency conversion products, but exclude out-of-band emissions.
- 3.1.35 subscriber station (SS): A generalized equipment set providing connectivity between subscriber equipment and a base station.
- 3.1.36 synchronized transmissions: Harmonized time-division duplex (TDD) transmissions.
- 3.1.37 terminal equipment: Terminal equipment encompasses a wide variety of apparatus at customer premises, providing end user services and connecting to subscriber station equipment (SS) via one or more interfaces.
- 3.1.38 time-division duplex (TDD): A duplex scheme where uplink and downlink transmissions occur at different times but may share the same frequency.
- 3.1.39 uplink: The direction from a subscriber station to the base station.
- 3.1.40 unwanted emissions: Out-of-band emissions, spurious emissions, and harmonics.
- 3.1.41 virtual block edge: A reference frequency used as a block edge frequency for testing of unwanted emissions so as to avoid effects of radio frequency (RF) block filters.
- 3.1.42 wireless access: End-user radio connection(s) to core networks.

Abbreviations

AdjCh	adjacent channel
ATPC	automatic transmit power control
AZ	azimuth
BER	bit error ratio
BFWA	broadband fixed wireless access
B _o	occupied bandwidth
BRAN	broadband radio access networks (an ETSI Project)
BS	base station
BW	bandwidth
BWA	broadband wireless access
CDF	cumulative distribution function
CDMA	code division multiple access
CEPT	Conférence Européenne des Administrations des Postes et des Télécommunications (European Conference of Postal and Telecommunication Administrations)
C/I	carrier-to-interference ratio

C/N	carrier-to-noise ratio
C/(N+I)	carrier-to-noise and interference ratio
CoCh	co-channel
CS	central station (used in Annexes only); or channel separation (in 6.1.3 only)
CW	continuous wave
dBc	decibels relative to the carrier level
dBi	gain relative to a hypothetical isotropic antenna
DRS	data relay satellite
DS-3	44.736 Mbit/s line rate
D/U	desired carrier-to-undesired carrier ratio
EL	elevation
EIRP	effective isotropic radiated power
EN	European norm
ERC	European Radiocommunications Committee
ETSI	European Telecommunications Standards Institute
FCC	Federal Communications Commission (USA)
FDD	frequency division duplex
FDMA	frequency division multiple access
FSPL	free space path loss
FWA	fixed wireless access
GSO	geostationary orbit
IA	Interference area
IC	Industry Canada
IEC	International Electrotechnical Commission
IEEE	Institute of Electrical and Electronics Engineers, Inc.
I/N	interference-to-thermal noise ratio
ISOP	interference scenario occurrence probability
ITU	International Telecommunication Union
ITU-R	International Telecommunication Union R Radiocommunication Sector
LMCS	local multipoint communication system
LMDS	local multipoint distribution service
LOS	line of sight
MAN	metropolitan area network
MCL	minimum coupling loss
MP	multipoint
MP-MP	multipoint-to-multipoint
MWS	multimedia wireless systems
NFD	net filter discrimination
OC-3	155.52 Mbit/s line rate
OFDM	orthogonal frequency division multiplexing
OOB	out-of-block
PCS	personal communication service
pdf	power flux density
PMP	point-to-multipoint
psd	power spectral density
psfd	power spectral flux density
PTP	point-to-point
QAM	quadrature amplitude modulation

2002-05-10

IEEE C802.16.2a-02/27

QPSK quadrature phase shift keying
RA Radiocommunications Agency
RABC Radio Advisory Board of Canada
RF radio frequency
RPE radiation pattern envelope
RS repeater station
RSS Radio Standards Specifications
Rx receive
SRSP Standard Radio Systems Plan
SS subscriber station
TDD time division duplex
TDMA time division multiple access
TS terminal station
Tx transmit
XPD cross-polar discrimination

Part 1 Coexistence of Fixed Broadband Wireless Access Systems operating in the Frequency Range 23.5 – 43.5 GHz

[Editor's note: insert text from published Recommended Practice here, starting at section 4 and ending after annex F. Review in Task Group. Note the need to update some parts, to review the B0 issue and to include text relating to the published IEEE Interpretation.]

[revise section numbering]

[review following draft text for part 1 scope]

Editorial instruction: Insert new scope section as follows:-

Scope of part 1

Part 1 of this Recommended Practice defines a set of consistent design and deployment recommendations that promote coexistence for fixed BWA systems that share the same bands. The recommendations have been developed and substantiated by appropriate analyses and simulations. The recommendations, if followed by manufacturers and operators, will facilitate a wide range of equipment to coexist in a shared environment with acceptable mutual interference.

The scope of this Part 1 of the Recommended Practice includes the examination of interference between systems deployed across geographic boundaries in the same frequency blocks and systems deployed in the same geographic area in adjacent frequency blocks.

This document is not intended to be a replacement for applicable regulations, which would take precedence.

Summary of fixed BWA coexistence recommendations and guidelines

Document philosophy [revise heading]

Radio waves permeate through legislated (and even national) boundaries and emissions spill outside spectrum allocations. Coexistence issues between multiple operators are therefore inevitable. The resolution of coexistence issues is an important factor for the fixed BWA industry. The Recommendations in 4.2 are provided for consideration by operators, manufacturers, and administrations to promote coexistence. Practical implementation within the scope of the current recommendations will assume that some portion of the frequency spectrum (at the edge of the authorized bandwidth) may be unusable. Furthermore, some locations within the service area may not be usable for deployment. Coexistence will rely heavily on the good-faith collaboration between spectrum holders to find and implement economical solutions. The document analyzes coexistence using two scenarios:

- A co-channel (CoCh) scenario in which two operators are in either adjacent territories or territories within radio line of sight of each other and have the same spectrum allocation, and
- An adjacent Channel (AdjCh) scenario in which the licensed territories of two operators overlap and they are assigned adjacent spectrum allocations.

Coexistence issues may arise simultaneously from both scenarios as well as from these scenarios involving multiple operators. As a starting point for the consideration of tolerable levels of interference into fixed BWA

systems, ITU-R Recommendation F.758-2 [B16] details two generally accepted values for the interference-to-thermal noise ratio (I/N) for long-term interference into fixed service receivers. When considering interference from other services, it identifies an I/N value of -6dB or -10dB matched to specific requirements of individual systems. This approach provides a method for defining a tolerable limit that is independent of most characteristics of the victim receiver, apart from noise figure, and has been adopted for this Recommended Practice. The acceptability of any I/N value needs to be evaluated against the statistical nature of the interference environment. In arriving at the Recommendations in this document this evaluation has been carried out for an I/N value of -6 dB.

Clause 9 provides interference mitigation measures that can be utilized to solve coexistence problems. Because of the wide variation in subscriber station and base station distribution, radio emitter/receiver parameters, localized rain patterns, and the statistics of overlapping emissions in frequency and time, it is impossible to prescribe in this document which of the mitigation measures are appropriate to resolving a particular coexistence problem. In the application of these mitigation measures, identification of individual terminals or groups of terminals for modification is preferable to the imposition of pervasive restrictions.

Implementing the measures suggested in Recommendations 8E10 in 4.2 using the suggested equipment parameters in Clause 6 will, besides improving the coexistence conditions, have a generally positive effect on intrasystem performance. Similarly, simulations performed in the preparation of this Recommended Practice suggest that most of the measures undertaken by an operator to promote intrasystem performance will also promote coexistence. It is outside the scope of this document to make recommendations that touch on intrasystem matters such as frequency plans, frequency reuse patterns, etc.

Recommendations

Recommendation 1

Adopt a criterion of 6 dB below receiver thermal noise (i.e., I/N \geq 6 dB) in the victim receiver as an acceptable level of interference from a transmission of an operator in a neighboring area. The document recommends this value in recognition of the fact that it is not practical to insist upon an interference-free environment. Having once adopted this value, the following are some important consequences: -Each operator accepts a 1 dB degradation [the difference in dB between C/N and C/(N + I)] in receiver sensitivity. In some regard, an I/N of \geq 6 dB becomes the fundamental criterion for coexistence. The very nature of the MP system is that receivers must accept interference from intrasystem transmitters. Although a good practice would be to reduce the intrasystem interference level to be well below the thermal noise level (see Recommendation 6 in 4.2.6), this is not always feasible. The actual level of external interference could be higher than the limit stated above and still be not controlling, or comparable to the operator's intrasystem interference. Thus, there is some degree of interference allocation that could be used to alleviate the coexistence problem.

- Depending upon the particular deployment environment, an operator's receiver may have interference contributions from multiple CoCh and AdjCh operators. Each operator should include design margin capable of simultaneously accepting the compound effect of interference from all other relevant operators. The design margin should be included preemptively at initial deployment, even if the operator in question is the first to deploy in a region and is not experiencing interference.

All parties should recognize that, in predicting signal levels that result in the \geq 6 dB interference value, it is difficult to be precise in including the aggregating effect of multiple terminals, the effect of uncorrelated rain, etc. Therefore, all parties should be prepared to investigate claims of interference even if the particular assessment method used to substantiate the \geq 6 dB value predicts that there should not be any interference.

Recommendation 2

Each operator should take the initiative to collaborate with other known operators prior to initial deployment and prior to every relevant system modification. This recommendation should be followed even if an operator is the first to deploy in a region. To encourage this behavior for co-channel interference, this document introduces the concept of using power spectral flux density values to “trigger” different levels of initiatives taken by an operator to give notification to other operators. The specific trigger values and their application to the two deployment scenarios are discussed in Recommendation 5 (4.2.5) and Recommendation 6 (4.2.6) and in Clause 7

Recommendation 3

In the resolution of coexistence issues, in principle, incumbents and first movers should coordinate with operators who deploy at a later time. In resolving coexistence issues, it is legitimate to weigh the capital investment an incumbent operator has made in his or her system. It is also legitimate to weigh the capital investment required by an incumbent operator for a change due to coexistence versus the capital investment costs that the new operator will incur. The logic behind this Recommendation is that some coexistence problems cannot be resolved simply by modifying the system of a new entrant into a region. Rather, they require the willingness of an incumbent to make modifications as well. It is recognized that this Recommendation is especially challenging in the AdjCh scenario where overlapping territories imply that the incumbent and the late-comer may be competing for the same clients. The reality of some spectrum allocations are such that AdjCh operators will be allocated side-by-side frequency channels. As is seen below, this is an especially difficult coexistence problem to resolve without co-location of the operator’s cell sites.

Recommendation 4

No coordination is needed in a given direction if the transmitter is greater than 60 km from either the service area boundary or the neighbor’s boundary (if known) in that direction. Based on typical fixed BWA equipment parameters and an allowance for potential LOS interference couplings, subsequent analysis indicates that a 60 km boundary distance is sufficient to preclude the need for coordination. At lesser distances, coordination may be required, but this is subject to a detailed examination of the specific transmission path details that may provide for interference link excess loss or blockage. This coordination criteria is viewed to be necessary and appropriate for both systems that conform to this Recommended Practice and those that do not.

Recommendation 5

(This Recommendation applies to co-channel cases only.) Recommendation 2 above introduced the concept of using power spectral flux density “triggers” as a stimulus for an operator to take certain initiatives to collaborate with his or her neighbor. It is recommended that regulators specify the applicable trigger values for each frequency band, failing which the following values may be adopted: The coordination trigger values (see Annex B) of ≤ 114 (dBW/m²)/MHz (24, 26, and 28 GHz bands) and ≤ 111 (dBW/m²)/MHz (38 and 42 GHz bands) are employed in the initiative procedure described in Recommendation 6 (4.2.6). The evaluation point for the trigger exceedance may be at either the victim operator’s licensed area boundary, the interfering operator’s boundary, or at a defined point in between depending to some extent on the specific geographic circumstances of the BWA licensing. These values were derived as that power spectral flux density values which, if present at a typical point-to-multipoint base station antenna and typical receiver, would result in approximately the ≤ 6 dB interference value cited in Recommendation 1. It should be emphasized that the trigger values are useful only as thresholds for taking certain actions with other operators; they do not make an absolute statement as to whether there is, or is not, interference potential. In cases of significant deployment of point-to-point systems alongside point-to-multipoint systems where protection of the point-to-point systems is mandated, tighter psfd trigger levels may be appropriate. For example, ≤ 125 (dBW/m²)/MHz at 38 GHz band is applied by some administrations to protect point-to-point links.

Recommendation 6

(This Recommendation applies to co-channel cases only.)

The “triggers” of Recommendation 5 and Recommendation 6 should be applied prior to deployment and prior to each relevant system modification. Should the trigger values be exceeded, the operator should try to modify the deployment to meet the trigger or, failing this, the operator should coordinate with the affected operator. Three existing coordination procedures are described in D, E, and F.

Recommendation 7

For same area/adjacent channel interference cases, analysis and simulation indicate that deployment may require an equivalent guard frequency between systems operating in close proximity and in adjacent frequency blocks. It is convenient to think of the “guard frequency” in terms of “equivalent channels” related to the systems operating at the edges of the neighboring frequency blocks. The amount of guard frequency depends on a variety of factors such as “out of block” emission levels and in some cases is linked to the probability of interference in given deployment scenarios. Clause 8 provides insight into some methods that can be employed to assess these situations, while Clause 9 describes some possible interference mitigation techniques. These mitigation techniques include frequency guard bands, recognition of cross-polarization differences, antenna angular discrimination, spatial location differences, and frequency assignment substitution. In most co-polarized cases, where the transmissions in each block are employing the same channel bandwidth, the guard frequency should be equal to one equivalent channel. Where the transmissions in neighboring blocks employ significantly different channel bandwidths, it is likely that a guard frequency equal to one equivalent channel of the widest bandwidth system will be adequate. However, analysis suggests that, under certain deployment circumstances, this may not offer sufficient protection and that a guard frequency equal to one channel at the edge of each operator’s block may be required. Where administrations do not set aside guard channels, the affected operators would need to reach agreement on how the guard channel is apportioned between them. It is possible that, with careful and intelligent frequency planning, coordination, and/or use of orthogonal polarization or other mitigation techniques, all or partial use of this guard channel may be achieved. However, in order to minimize interference conflicts and at the same time maximize spectrum utilization, cooperative deployment between operators will be essential. This recommendation strongly proposes this.

Recommendation 8

Utilize antennas for the base station and subscriber stations at least as good as the Class 1 antennas described in 6.2. The coexistence simulations which led to the Recommendations contained herein revealed that a majority of coexistence problems are the result of main-beam interference. The sidelobe levels of the base station antennas are of a significant but secondary influence. The sidelobe levels of the subscriber antenna are of tertiary importance. In the context of coexistence, therefore, antennas such as those presented in 6.2 are sufficient. It should be emphasized that utilizing antennas with sidelobe (and polarization) performance better than the minimum will not degrade the coexistence performance and, in fact, is an effective mitigation technique for specific instances. In many cases, intrasystem considerations may place higher demands on antenna performance than those required for intersystem coordination.

Recommendation 9

Utilize an emission mask at least as good as that described in 6.1.3. The utility of emission masks for controlling adjacent channel coexistence issues is strongly dependent upon the separation of the two emitters in space and in frequency. In case of large spatial separation between emitters, the opportunity exists for an interfering emitter to be much closer to a receiver than the desired emitter. This unfavorable range differential can overwhelm even the best emission mask. Likewise, emission masks are most effective when at least one guard channel exists between allocations. The emission mask presented in 6.1.3 is most appropriate for the case in which a guard channel

separates allocations and emitters are modestly separated. For cases with no guard band, it is recommended that co-location of harmonized base station emitters be considered before trying to improve emission masks.

Recommendation 10

Limit maximum EIRP in accordance with recommendations in 6.1.1 and use SS power control in accordance with recommendations in 6.1.1.5. The interests of coexistence are served by reducing the amount of EIRP emitted by base, SS, and repeater stations. The proposed maximum EIRP spectral density values are significantly less than allowed by some regulatory agencies but should be an appropriate balance between constructing robust fixed BWA systems and promoting coexistence.

Recommendation 11

In conducting analyses to predict power spectral flux density and for coordination purposes, the following should be considered:

- a) Calculations of path loss to a point on the border should consider:
 - 1) Clear air (no rain) plus relevant atmospheric absorption
 - 2) Intervening terrain blockage
- b) For the purpose of calculating psfd trigger compliance level, the psfd level at the service area boundary should be the maximum value which occurs at some elevation point up to 500 m above local terrain elevation. Equations (B.2) and (B.3) in Annex B should be used to calculate the psfd limits.
- c) Actual electrical parameters (e.g., EIRP, antenna patterns, etc.) should be used.
- d) Clear sky propagation (maximum path length) conditions should be assumed. Where possible, use established ITU-R Recommendations relating to propagation (e.g., Recommendation ITU-R P.452 [B20]).

Suggested guidelines for geographical and frequency spacing

This subclause and Clause 8 indicate some of the models, simulations, and analysis used in the preparation of this Recommended Practice. While a variety of tools may be used, the scenarios studied below should be considered when coordination is required. Guidelines for geographical and frequency spacing of fixed BWA systems that would otherwise mutually interfere are given in 8.1 for each of a number of interfering mechanisms. This subclause summarizes the overall guidelines, taking into account all the identified interference mechanisms. The two main deployment scenarios are as follows:

- Co-channel systems that are geographically spaced
- Systems that overlap in coverage and (in general) require different frequencies of operation

The most severe of the several mechanisms that apply to each case determines the guideline spacing, as shown in Table 1: ~~delete colon?~~

The guidelines are not meant to replace the coordination process described in Clause 7. However, in many (probably most) cases, these guidelines will provide satisfactory psfd levels at system boundaries. The information is therefore valuable as a first step in planning the deployment of systems.

System overview

BWA generally refers to fixed radio systems used primarily to convey broadband services between users' premises and core networks. The term "broadband" is usually taken to mean the capability to deliver significant bandwidth to each user. In ITU terminology, and in this document, broadband transmission refers to transmission rate of greater than around 1.5 Mbit/s, though many BWA networks support significantly

Table 1: Summary of the guidelines for geographical and frequency spacing

Dominant interference path(note 1)	Scenario	Spacing at which interference is below target level (generally 6 dB below receiver noise floor)
PMP BS to PMP BS	Adjacent area, same channel	60 km (note 5)
Mesh SSs to PMP BS	Adjacent area, same channel	12 km (note 2)
PMP BS to PMP BS	Same area, adjacent channel	1 guard channel (notes 3 and 5)
Mesh SSs to PMP SS	Same area, adjacent channel	1 guard channel (note 4)

NOTES

1 -The dominant interference path is that which requires the highest guideline geographical or frequency spacing.

2 -The 12 km value is based on a BS at a typical 50 m height. For other values, the results change to some extent, but are always well below the 60 km value calculated for the PMP CE PMP case.

3 -The single guard channel spacing is based on both interfering and victim systems using the same channel size. Where the transmissions in neighboring blocks employ significantly different channel bandwidths then it is likely that a guard frequency equal to one equivalent channel of the widest bandwidth system will be adequate. However, analysis suggests that, under certain deployment circumstances, this may not offer sufficient protection and that a guard frequency equal to one channel at the edge of each operator's block may be required.

4 -The single guard channel spacing for mesh to PMP is based on both interfering and victim systems using the same channel size. This may be reduced in some circumstances. Where the transmissions in neighboring blocks employ significantly different channel bandwidths, it is likely that a guard frequency equal to one equivalent channel of the widest bandwidth system will be adequate. However, analysis suggests that under certain deployment circumstances this may not offer sufficient protection and that a guard frequency equal to one channel at the edge of each operatorTMs block may be required.

5 -In a case of harmonized FDD band plans and/or frequency reassignable TDD systems, the BS-to-BS case ceases to be dominant.

higher data rates. The networks operate transparently, so users are not aware that services are delivered by radio. A typical fixed BWA network supports connection to many user premises within a radio coverage area. It provides a pool of bandwidth, shared automatically among the users. Demand from different users is often

statistically of low correlation, allowing the network to deliver significant bandwidth-on-demand to many users with a high level of spectrum efficiency. Significant frequency reuse is employed.

The range of applications is very wide and evolving quickly. It includes voice, data, and entertainment services of many kinds. Each subscriber may require a different mix of services; this mix is likely to change rapidly as connections are established and terminated. Traffic flow may be unidirectional, asymmetrical, or symmetrical, again changing with time. In some territories, systems delivering these services are referred to as multimedia wireless systems (MWS) in order to reflect the convergence between traditional telecommunications services and entertainment services.

These radio systems compete with other wired and wireless delivery means for the “first mile” connection to services. Use of radio or wireless techniques result in a number of benefits, including rapid deployment and relatively low “up-front” costs.

System architecture

Fixed BWA systems often employ multipoint architectures. The term multipoint includes point-to-multipoint (PMP) and multipoint-to-multipoint (MP-MP). The IEEE 802.16 Working Group on Broadband Wireless Access (see Clause 2) is developing standards for PMP systems with base stations and subscriber stations communicating over a fully specified air interface. A similar PMP standard is being developed within the “HIPERACCESS” topic within ETSI Project BRAN 7. Coexistence specifications for MWS (which includes

PMP Systems

[old text OK?]

MP systems (Mesh)

[old text OK?]

System components

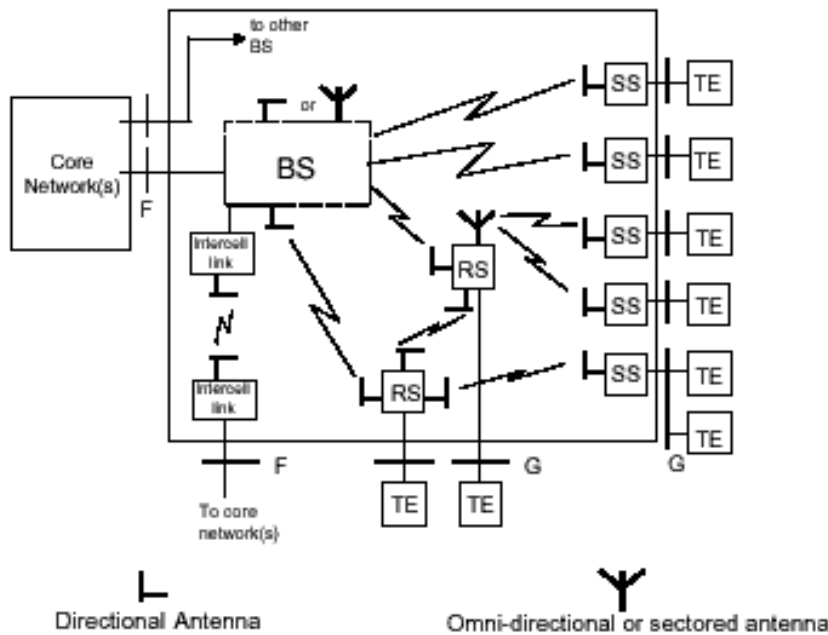

SOURCE: ETSI 301 390 v1.1.1 (2000 – 12) [is this the correct reference – it seems to be a diagram from the 40 GHz MWS specification?]

Figure 1 – Interference Sources to a fixed BWA BS [Review this title – it is really a reference diagram]

Medium Overview

[keep original text]

Interference Scenarios

[keep original text]

- Forms of Interference
- Acceptable level of interference
- Interference paths
 - Victim BS
 - Victim subscriber station

Equipment design Parameters

[keep original text]

Transmitter design parameters

[keep original text]

Maximum EIRP spectral density limits

Base station
Subscriber station
Repeater station
In – band intercell links
Uplink power control
Downlink power control

Frequency tolerance or stability

Out – of – block unwanted emissions

[review this section; B(0) issue]

Antenna parameters

[keep original text]

Receiver design parameters

[keep original text]

Deployment and coordination

[keep original text]

Co frequency, adjacent area

[keep original text]

Same area/ adjacent frequency

[keep original text]

Use of power spectral flux density (psfd) as a coexistence metric

[keep original text]

Deployment procedure

[keep original text]

Interference and propagation evaluation/ examples of coexistence in a PMP environment

[keep original text]

Guidelines for geographical and frequency spacing between fixed BWA systems

[keep original text]

Mitigation techniques

[keep original text]

Annexes A to F

2002-05-10

IEEE C802.16.2a-02/27

[keep original text; review headings and position in document. Add archive references to annex C]

Editorial instruction: Add complete new section (part 2) as follows [starts at Part 2 heading and ends attba]

Part 2. Coexistence of Fixed Broadband Wireless Access Systems operating in the Frequency Range 23.5 – 43.5 GHz with point- to- point links, sharing the same frequency band.

Delete? [This section extends the work of IEEE802.16.2 to include interference with point to point links. The frequency range studied is the same as in part a (i.e. 23.5 – 43.5 GHz)]

[Overview of section] Scope of Part 2

Old text – delete? [This section contains guidelines and recommendations for coexistence between PMP systems and point to point link systems, corresponding to two main scenarios. The guidelines and recommendations are supported by the results of a large number of simulations or representative interference cases. The full details of the simulation work are contained in input documents, referenced in section 4. This section lists the full set of archived input documents used in the preparation of this document and in the preparation of the published recommended practice.]

New text to be added as follows?;

Part 2 of this document defines a set of consistent design and deployment recommendations that promote coexistence between fixed BWA systems and point-to-point systems that share the same bands. The analysis covers frequency range 2 (23.5-43.5 GHz). Each scenario considers the case where one component is a single PP link or a system comprising multiple PP links and the other component is a fixed BWA system, which may be the victim or the interferer.

The recommendations have been developed and substantiated by appropriate analysis and simulations relevant to system interference experienced between operators licensed for fixed BWA and operators of point-to-point link systems sharing the same bands. These recommendations, if followed by manufacturers and operators, will facilitate a wide range of equipment to coexist in a shared environment with acceptable mutual interference.

The scope of this Recommended Practice includes the examination of interference between systems deployed across geographic boundaries in the same frequency blocks and systems deployed in the same geographic area in adjacent frequency blocks.

This Recommended Practice does not cover coexistence issues due to intra -system frequency reuse within the operator's authorized band, and it does not consider the impact of interference created by fixed BWA systems on satellite systems. This document is not intended to be a replacement for applicable regulations, which would take precedence.

[Scope statement (summary of what scenarios have been studied – derived from PAR)] delete?

Recommendations and Guidelines, including indicative geographical and physical spacing between systems.

Recommendations

[list to be reviewed – the following is the complete set of those in the published recommended practice and needs to be assessed by the task group. e.g. rec. 1, 2, 3, 4, plus modified versions of rec. 5,6,7 and new recommendations concerning antennas, emission masks and EIRP limits may be required]
[numbering?]

Recommendation 1

Adopt a criterion of 6 dB below receiver thermal noise (i.e., $I/N = -6$ dB) in the victim receiver as an acceptable level of interference from a transmission of an operator in a neighboring area. The document recommends this value in recognition of the fact that it is not practical to insist upon an interference-free environment. Having once adopted this value, the following are some important consequences: -Each operator accepts a 1 dB degradation [the difference in dB between C/N and $C/(N + I)$] in receiver sensitivity. In some regard, an I/N of -6 dB becomes the fundamental criterion for coexistence. The very nature of the MP system is that receivers must accept interference from intrasystem transmitters. Although a good practice would be to reduce the intrasystem interference level to be well below the thermal noise level (see Recommendation 6 in 4.2.6), this is not always feasible. The actual level of external interference could be higher than the limit stated above and still be not controlling, or comparable to the operator's intrasystem interference. Thus, there is some degree of interference allocation that could be used to alleviate the coexistence problem.

- Depending upon the particular deployment environment, an operator's receiver may have interference contributions from multiple CoCh and AdjCh operators. Each operator should include design margin capable of simultaneously accepting the compound effect of interference from all other relevant operators. The design margin should be included preemptively at initial deployment, even if the operator in question is the first to deploy in a region and is not experiencing interference.

All parties should recognize that, in predicting signal levels that result in the ≤ 6 dB interference value, it is difficult to be precise in including the aggregating effect of multiple terminals, the effect of uncorrelated rain, etc. Therefore, all parties should be prepared to investigate claims of interference even if the particular assessment method used to substantiate the ≤ 6 dB value predicts that there should not be any interference.

Recommendation 2

Each operator should take the initiative to collaborate with other known operators prior to initial deployment and prior to every relevant system modification. This recommendation should be followed even if an operator is the first to deploy in a region. To encourage this behavior for co-channel interference, this document introduces the concept of using power spectral flux density values to "trigger" different levels of initiatives taken by an operator to give notification to other operators. The specific trigger values and their application to the two deployment scenarios are discussed in Recommendation 5 (4.2.5) and Recommendation 6 (4.2.6) and in Clause 7

Recommendation 3

In the resolution of coexistence issues, in principle, incumbents and first movers should coordinate with operators who deploy at a later time. In resolving coexistence issues, it is legitimate to weigh the capital investment an incumbent operator has made in his or her system. It is also legitimate to weigh the capital investment required by an incumbent operator for a change due to coexistence versus the capital investment costs that the new operator will incur. The logic behind this Recommendation is that some coexistence problems cannot be resolved simply by modifying the system of a new entrant into a region. Rather, they require the willingness of an incumbent to

make modifications as well. It is recognized that this Recommendation is especially challenging in the AdjCh scenario where overlapping territories imply that the incumbent and the late-comer may be competing for the same clients. The reality of some spectrum allocations are such that AdjCh operators will be allocated side-by-side frequency channels. As is seen below, this is an especially difficult coexistence problem to resolve without co-location of the operator's cell sites.

Recommendation 4

No coordination is needed in a given direction if the transmitter is greater than 60 km from either the service area boundary or the neighbor's boundary (if known) in that direction. Based on typical fixed BWA equipment parameters and an allowance for potential LOS interference couplings, subsequent analysis indicates that a 60 km boundary distance is sufficient to preclude the need for coordination. At lesser distances, coordination may be required, but this is subject to a detailed examination of the specific transmission path details that may provide for interference link excess loss or blockage. This coordination criteria is viewed to be necessary and appropriate for both systems that conform to this Recommended Practice and those that do not.

Recommendation 5

This Recommendation applies to co-channel cases only.) Recommendation 2 above introduced the concept of using power spectral flux density "triggers" as a stimulus for an operator to take certain initiatives to collaborate with his or her neighbor. It is recommended that regulators specify the applicable trigger values for each frequency band, failing which the following values may be adopted: The coordination trigger values (see Annex B) of ≤ 114 (dBW/m²)/MHz (24, 26, and 28 GHz bands) and ≤ 111 (dBW/m²)/MHz (38 and 42 GHz bands) are employed in the initiative procedure described in Recommendation 6 (4.2.6). The evaluation point for the trigger exceedance may be at either the victim operator's licensed area boundary, the interfering operator's boundary, or at a defined point in between depending to some extent on the specific geographic circumstances of the BWA licensing. These values were derived as that power spectral flux density values which, if present at a typical point-to-multipoint base station antenna and typical receiver, would result in approximately the ≤ 6 dB interference value cited in Recommendation 1. It should be emphasized that the trigger values are useful only as thresholds for taking certain actions with other operators; they do not make an absolute statement as to whether there is, or is not, interference potential. In cases of significant deployment of point-to-point systems alongside point-to-multipoint systems where protection of the point-to-point systems is mandated, tighter psfd trigger levels may be appropriate. For example, ≤ 125 (dBW/m²)/MHz at 38 GHz band is applied by some administrations to protect point-to-point links.

Recommendation 6

(This Recommendation applies to co-channel cases only.)

The "triggers" of Recommendation 5 and Recommendation 6 should be applied prior to deployment and prior to each relevant system modification. Should the trigger values be exceeded, the operator should try to modify the deployment to meet the trigger or, failing this, the operator should coordinate with the affected operator. Three existing coordination procedures are described in D, E, and F.

Recommendation 7

For same area/adjacent channel interference cases, analysis and simulation indicate that deployment may require an equivalent guard frequency between systems operating in close proximity and in adjacent frequency blocks. It is convenient to think of the "guard frequency" in terms of "equivalent channels" related to the systems operating at the edges of the neighboring frequency blocks. The amount of guard frequency depends on a variety of factors such as "out of block" emission levels and in some cases is linked to the probability of interference in given deployment scenarios. Clause 8 provides insight into some methods that can be employed to assess these situations, while Clause 9 describes some possible interference mitigation techniques. These mitigation

techniques include frequency guard bands, recognition of cross-polarization differences, antenna angular discrimination, spatial location differences, and frequency assignment substitution. In most co-polarized cases, where the transmissions in each block are employing the same channel bandwidth, the guard frequency should be equal to one equivalent channel. Where the transmissions in neighboring blocks employ significantly different channel bandwidths, it is likely that a guard frequency equal to one equivalent channel of the widest bandwidth system will be adequate. However, analysis suggests that, under certain deployment circumstances, this may not offer sufficient protection and that a guard frequency equal to one channel at the edge of each operator's block may be required. Where administrations do not set aside guard channels, the affected operators would need to reach agreement on how the guard channel is apportioned between them. It is possible that, with careful and intelligent frequency planning, coordination, and/or use of orthogonal polarization or other mitigation techniques, all or partial use of this guard channel may be achieved. However, in order to minimize interference conflicts and at the same time maximize spectrum utilization, cooperative deployment between operators will be essential. This recommendation strongly proposes this.

Recommendation 8

Utilize antennas for the base station and subscriber stations at least as good as the Class 1 antennas described in 6.2. The coexistence simulations which led to the Recommendations contained herein revealed that a majority of coexistence problems are the result of main-beam interference. The sidelobe levels of the base station antennas are of a significant but secondary influence. The sidelobe levels of the subscriber antenna are of tertiary importance. In the context of coexistence, therefore, antennas such as those presented in 6.2 are sufficient. It should be emphasized that utilizing antennas with sidelobe (and polarization) performance better than the minimum will not degrade the coexistence performance and, in fact, is an effective mitigation technique for specific instances. In many cases, intrasystem considerations may place higher demands on antenna performance than those required for intersystem coordination.

Recommendation 9

Utilize an emission mask at least as good as that described in 6.1.3. The utility of emission masks for controlling adjacent channel coexistence issues is strongly dependent upon the separation of the two emitters in space and in frequency. In case of large spatial separation between emitters, the opportunity exists for an interfering emitter to be much closer to a receiver than the desired emitter. This unfavorable range differential can overwhelm even the best emission mask. Likewise, emission masks are most effective when at least one guard channel exists between allocations. The emission mask presented in 6.1.3 is most appropriate for the case in which a guard channel separates allocations and emitters are modestly separated. For cases with no guard band, it is recommended that co-location of harmonized base station emitters be considered before trying to improve emission masks.

Recommendation 10

Limit maximum EIRP in accordance with recommendations in 6.1.1 and use SS power control in accordance with recommendations in 6.1.1.5. The interests of coexistence are served by reducing the amount of EIRP emitted by base, SS, and repeater stations. The proposed maximum EIRP spectral density values are significantly less than allowed by some regulatory agencies but should be an appropriate balance between constructing robust fixed BWA systems and promoting coexistence.

Recommendation 11

In conducting analyses to predict power spectral flux density and for coordination purposes, the following should be considered:

a) Calculations of path loss to a point on the border should consider:

1) Clear air (no rain) plus relevant atmospheric absorption

2) Intervening terrain blockage

b) For the purpose of calculating psfd trigger compliance level, the psfd level at the service area boundary should be the maximum value which occurs at some elevation point up to 500 m above local terrain elevation. Equations (B.2) and (B.3) in Annex B should be used to calculate the psfd limits.

c) Actual electrical parameters (e.g., EIRP, antenna patterns, etc.) should be used.

d) Clear sky propagation (maximum path length) conditions should be assumed. Where possible, use established ITU-R Recommendations relating to propagation (e.g., Recommendation ITU-R P.452 [B20]).

Suggested guidelines for geographical and frequency spacing

This subclause summarizes the models, simulations and analysis used in Part 2 of this Recommended Practice and provides guidelines for the most severe of the mechanisms identified. The complete set of interference mechanisms is described in [1].

Dominant Path (Note 1)	Interference Scenario	Spacing at which interference is below target level (generally 6dB below receiver noise floor)
PMP BS to PP link station	Adjacent area, same channel	Tba km
PP link station to PMP BS	Adjacent area, same channel	Tba km
PMP BS to PP link station	Same area, adjacent channel	Tba guard channels
PP link station to PMP BS	Same area, adjacent channel	Tba guard channels
PMP BS to multi PP link system	Adjacent area, same channel	Tba km
multi PP link system to PMP BS	Adjacent area, same channel	Tba km
PMP BS to multi PP link system	Same area, adjacent channel	Tba guard channels
multi PP link system to PMP BS	Same area, adjacent channel	Tba guard channels
Notes 1- the dominant interference path is that which requires the highest value for the guideline geographical or frequency spacing 2- the guard channel size assumes that the interferer and victim use the same channel size [what if not? Also, could state in terms of equivalent isolation, rather than number of guard channels]		

System overview (interferer and victim systems)

In all cases, a Fixed BWA system is present and may be the victim or interferer. The other system is a point to point link or an arrangement of several point to point links. There are two main licensing scenarios for the point to point link component.

[insert new reference diagram]

Fixed BWA systems are described in Part 1 of this Recommended Practice [insert latest ref.]. They are generally of point to multipoint architecture, or sometimes multipoint to multipoint. Although information on base station (BS) locations may be readily available, subscriber stations (SS) are added and removed regularly and information on their locations is not usually available to third parties.

Point to point links are simple, generally line of sight, direct connections by radio, using narrow beam antennas. Once installed, they usually have a long lifetime without any changes being made to operating frequencies or other characteristics.

Interference scenario 1: multiple point to point links in a frequency block

In some territories, point- to- point links may share frequency bands with MP systems. In this scenario, the links are permitted to operate within a frequency block, and the operator assigns specific frequencies. The system operator decides the link frequencies within the block, determines the antenna characteristics and manages coexistence issues. The regulatory authority does not have responsibility for resolving interference issues, except possibly at block boundaries.

Because the point to point link arrangements can change over time, an analysis of interference is best carried out using Monte Carlo simulation techniques, to provide general guidelines for frequency and geographical spacing. The guidelines should be chosen so that the probability of interference above some chosen threshold is acceptably low.

Interference scenario 2: individually licensed links

In territories where point- to- point links share frequency bands with MP systems, the links are commonly individually licensed. In this scenario, the national regulator assigns the link frequencies, determines the antenna characteristics and manages coexistence issues. The operator of the PP link is not free to alter link frequencies or other characteristics without agreement of the regulator. The links are often given a “protected” status over the other services sharing the band, so that the onus is on the operator of the FBWA system to avoid generating unacceptable interference.

Because links are generally protected in this scenario, a worst - case analysis rather than a statistical approach is appropriate. The guidelines should be set so as to avoid all cases of unacceptable interference to (but not necessarily from) the point to point link.

System parameters assumed in the simulations

The following tables of parameters for point to point systems were developed as a starting point for simulations and other calculations used in the interference studies.

[insert latest version of the point to point parameters tables]

Table []: multi – link point to point systems

Characteristic (point to point systems)	Examples
Layout of system(s) including diagrams	Quasi – random layout of links Consider multiple star/hub configurations
Link lengths	50 to 5000m at 25 GHz 50 to 3000m at 38 GHz
Density of terminal stations	Up to 5/ sq km
Distribution of terminal stations in relation to link length	Uniform (all link lengths have same probability)
Frequency of operation (for each variant to be studied)	Circa 25GHz, circa 38GHz
Duplex method	FDD
Access method	N/A
Receiver parameters	
Channel bandwidth	12.5, 14, 25, 28, 50, 56 MHz Start analysis by assuming 25/28 MHz
filter response	Root Nyquist, 25% roll-off
noise floor	TBA (6dB noise figure at 25 GHz, 9dB at 38 GHz)
acceptable level for co-channel interference	I/N = -6dB (aggregate of all interferers)
Transmitter parameters	
Channel bandwidth	12.5, 14, 25, 28, 50, 56 MHz Start by assuming 25/28 MHz
emission mask	Depends on modulation – to be specified Assume ETSI or FCC (further discussion required)
maximum power	1W
Typical power	To meet link budget
use of ATPC, steps and range	Uplink and downlink, 2dB steps, 40dB range
Tx-Rx parameters	NFD (net filter discrimination; call for contributions needed)
Antenna characteristics (station at point of connection to backhaul or core network)	Composite RPE 1 ft antenna as per contribution from RW – note 1 Gain 40-42dBi tbc
Antenna characteristics (subscriber station)	Composite RPE 1 ft antenna as per contribution from RW - note 1 Gain 40-42dBi tbc
Antenna characteristics (repeater station)	Same as other antennas
Backhaul links	In – band, separate assignments

Table []: Discrete point to point links

(where assignments for point to point systems are made in the same frequency bands as FWA systems)

Characteristic (point to point systems)	Examples
Layout of system(s) including diagrams	Individual, planned link, coordinated by regulatory body
Link lengths	50 to 5000m at 25 GHz 50 to 3000m at 38 GHz
Density of terminal stations	N/A
Distribution of terminal stations in relation to link length	N/A
Frequency of operation (for each variant to be studied)	25GHz, 38GHz
Duplex method	FDD
Access method	N/A
Receiver parameters	
Channel bandwidth	12.5, 14, 25, 28, 50, 56 MHz Start analysis by assuming 25/28 MHz
filter response	Root Nyquist, 25% roll-off
noise floor	(6dB noise figure at 25 GHz, 9dB at 38 GHz)
acceptable level for co-channel interference	I/N = -6dB (aggregate of all interferers)
Transmitter parameters	
Channel bandwidth	12.5, 14, 25, 28, 50, 56 MHz Start by assuming 25/28 MHz
emission mask	Depends on modulation – to be specified Assume ETSI or FCC (further discussion required)
maximum power	1W
Typical power	To achieve link budget
use of ATPC, steps and range	Uplink and downlink, 2dB steps, 40dB range
Tx-Rx parameters	NFD (net filter discrimination). Use ETSI values if no other data available (call for contributions needed)
Antenna characteristics (station at point of connection to backhaul or core network)	Composite RPE 1ft and 2ft antenna(s) as per contribution from RW – note 1 Gain = 40-42dBi tbc
Antenna characteristics (subscriber station)	Composite RPE 1ft and 2ft antenna(s) as per contribution from RW – note 1 Gain = 40-42 dBi tbc
Antenna characteristics (repeater station)	N/A
Backhaul links	In – band, separate assignments

[Note: the tables could be moved to an appendix in the final document]

[Delete this text?: Some preliminary characteristics of point to point systems were derived in an output paper from session #14; IEEE 802.16.2-01/12 [3]. These and some variations on them have been used in the simulations, to test the sensitivity of the results to various parameters.

The main characteristics are as follows:

- Frequency = 28 GHz
- Polarisation = Vertical
- APC on, with step size = 4 dB
- Link antenna gain = 40/ 42 dBi
- % of links using same channel = 12.5
- Density of point to point links = 5/ 10 stations per sq km
- Area covered by links = 10 x 5 km
- Link length = 50 – 5000m
- Building density = 750/ sq km
- Fractional Building Area = 0.1
- Building Height Parameter = 0 to 7m]

Typical antenna characteristics

Research into typical antennas for links operating around 25GHz and around 38GHz has been used to compile a set of “composite” antenna characteristics. Whilst these are not intended as a basis for antenna design, they are considered to be;

- (a) adequate to meet reasonable interference objectives and
- (b) practically feasible (i.e. it could be expected that a number of manufacturers could supply antennas meeting these criteria).

These “composite” antenna RPES have therefore been adopted as the starting point for interference simulations.

[insert main results from Bob Whiting’s paper]

Interference Scenarios

Forms of interference

[repeat or edit or refer to the original section 5.3.1.1]

Acceptable level of interference

[repeat or edit or refer to the original section 5.3.1.2]

Interference Paths

[new text and diagrams needed]

Equipment design parameters

[refer to original section 6 for the PMP part plus the PP link parameters in the section “System parameters assumed in the simulations” above]

Antenna parameters

[refer to original section 6.2 for the PMP part plus the paper from Robert Whiting 802.16.2-01/14; “proposed antenna radiation pattern envelopes for coexistence study”]

Deployment and coordination

[do we need this section for this part of the recommended practice]

Description of Interference Evaluation/ example scenarios

[equivalent of section 8 of part 1]

Guidelines for geographical and frequency spacing between fixed BWA systems

The following subclauses describe the models, simulations and analysis used in [this part of] the preparation of this Recommended Practice. A number of interference scenarios have been identified that include point to point links as one system and a BFWA system as the other. For each scenario, a summary of the methodology for calculating interference levels is described and a guideline geographical or frequency spacing is derived.

Summary

This subclause provides guidelines for geographical and frequency spacings between fixed BWA systems and PP systems that would otherwise mutually interfere. The guidelines are not meant to replace the coordination process described in [Clause 7.] However, in many (probably most) cases, by following these guidelines, satisfactory operation will be possible. The information is therefore valuable as a first step in planning the deployment of systems. Because many point to point links have “protected” status, it will often be necessary to carry out further specific calculations or measurements. Any adjustments to system layout can then be made. These adjustments should be relatively small, except in unusual cases.

Interference mechanisms

Various interference mechanisms can reduce the performance of fixed BWA systems operating within interfering range of PP systems. Although intrasystem interference is often a significant source of performance degradation, it is not considered in this analysis. Its reduction to acceptable levels requires careful system design and deployment, but these are under the control of the operator, who may decide what constitutes an acceptable maximum level. Thus, only intersystem interference mechanisms, where inter-operator coordination may be appropriate, are considered here. In each frequency band assigned for fixed BWA use, different types of systems may be deployed, some conforming to IEEE 802.16 standards and some designed to other specifications. The bands may be shared with PP system of various kinds. Therefore, we consider a wide range of possibilities in determining the likely interference levels and methods for reduction to acceptable levels. The following are the two main scenarios, each with several variants:

- Co-channel systems that are geographically spaced
- Systems that overlap in coverage and (in general) require different frequencies of operation

The various potential BS-PP and SS-PP interference paths need to be considered to determine how much interference will occur. Between any two systems, several interference mechanisms may be operating

simultaneously [(see 5.3).] The geographical or frequency spacing (or both) necessary to reduce interference to acceptable levels is then determined by the most severe mechanism that occurs.

A number of techniques have been used to estimate intersystem interference. They are as follows:

- Worst case analysis
- Interference Area method
- Monte Carlo simulations

Each of these is described [in section]. The most appropriate method depends on the interference mechanism. In each case, geographical or frequency spacing between systems has been varied in the calculations until the interference is below an acceptable threshold. These values are shown in the tables of results as guidelines for nominal geographical or frequency spacing.

Simulations and calculations

Table [] summarizes the simulations and calculations undertaken for this part of the Recommended Practice. The most appropriate method has been selected, dependent on the scenario and interference path.

Table [] Summary of the simulations and calculations

[delete column 1 to be consistent with part1; add a column showing the guideline results; add a column referring to the relevant simulation contributions?]

	Scenario	PP system type	Area/ channel	Methodology
1	PMP BS to PP	Single link	Adjacent area, same channel	Worst case analysis
2	PMP SS to PP	Single link	Adjacent area, same channel	Worst case analysis
3	PP to PMP BS	Single link	Adjacent area, same channel	Worst case analysis
4	PP to PMP SS	Single link	Adjacent area, same channel	Worst case analysis
5	PMP BS to PP	Single link	Same area, adjacent channel	Worst case analysis
6	PMP SS to PP	Single link	Same area, adjacent channel	Worst case analysis
7	PP to PMP BS	Single link	Same area, adjacent channel	Worst case analysis
8	PP to PMP SS	Single link	Same area, adjacent channel	Worst case analysis
9	PMP BS to PP	Multi - link	Adjacent area, same channel	Worst case analysis
10	PMP SS to PP	Multi - link	Adjacent area, same channel	?
11	PP to PMP BS	Multi - link	Adjacent area, same channel	Monte Carlo simulation

12	PP to PMP SS	Multi - link	Adjacent area, same channel	Monte Carlo simulation
13	PMP BS to PP	Multi - link	Same area, adjacent channel	Worst case analysis
14	PMP SS to PP	Multi - link	Same area, adjacent channel	Worst case analysis
15	PP to PMP BS	Multi - link	Same area, adjacent channel	Monte Carlo simulation
16	PP to PMP SS	Multi - link	Same area, adjacent channel	Monte Carlo simulation
<p>Notes</p> <p>1 – a multi- link PP system means one in which a significant number of PP links are deployed by the operator in a block assignment, so that the interference created varies as the system evolves.</p>				

[Delete this clause?]

Variables

In the simulations, a number of parameters have been varied in order to test the sensitivity of the results to critical aspects of system design. In particular, antennas with various RPEs have been evaluated. In particular, simulations have been completed using data for antennas with a range of RPEs. While many of the simulation results show improvement with the use of antennas with enhanced RPEs, the relative value of the performance improvement was found to be modest for all of the antennas considered. On this basis, a good practice is to choose the best antenna possible, consistent with system economics. In some configurations, the intrasystem interference considerations will dominate the decision on antenna RPEs. Effective frequency reuse between cells will demand the use of antennas whose intrasystem requirements can provide satisfactory intersystem interference levels.]

Results of the analysis

Simulations have been undertaken for [many of] the interference mechanisms described below. A summary of each method and its results is given in Annex []

Co-channel case

BS-to-PP co-polar, co – channel case

[new proposed text]:

This scenario occurs where the victim PP receiver is co-channel to the interfering BS transmitter(s). Multiple interferers can occur when the PMP system has multiple cells/ sectors with a frequency reuse pattern. The BS-to-PP interference is not usually the worst case, but has a relatively high probability because of the wide beamwidth of a typical BS antenna.

When the PP link receiver has protected status, it is essential when planning the system to reduce this kind of interference below the required threshold (typically an aggregate interference level not exceeding – 114.5dBm/MHz). The guideline system spacing for a randomly chosen PP link and BS antenna pointing direction will be large. For more reasonable distances, use must be made of antenna offsets or terrain and building losses or a combination of these and specific coordination is therefore usually required.

When the victim receiver is part of a multi-link PP system, the requirement for coordination will be reduced.

PP-to-BS, co-polar, co-channel case

In general, the victim receiver does not have “protected” status and so the system can be designed to give a low (but non – zero) probability of exceeding the interference threshold value.

When the interferer is a “protected” PP link, a relatively simple worst – case analysis of the interference can be carried out. The severity of the interference will depend on the PP link length. The probability of worst – case interference is generally low, since it only occurs when two highly directional antennas are aligned.

When the interferer is a multi- link PP system, a Monte Carlo analysis is more appropriate. This provides results indicating the probability of a range of interference values. The highest values are usually of very low probability and a view can be taken on a compromise system spacing that gives a low value of interference in most cases

SS to PP, co-polar, co-channel case

This scenario occurs where the victim PP receiver is co-channel to the interfering SS transmitter(s). Multiple interferers can occur because the PMP cell has multiple subscribers. These may or may not transmit simultaneously, dependent on the systems design. The PMP system may also have multiple cells/ sectors with a frequency reuse pattern. The SS-to-PP interference is usually worse than the BS – PP case. The probability of interference from a single SS is low because both interferer and victim use narrow beam antennas. However, the potential for multiple interferers is significant. These may transmit simultaneously (in which case, the interference must be aggregated) or separately (in which case the probability of a given value of interference may increase).

When the PP link receiver has protected status, it is essential when planning the system to reduce this kind of interference below the required threshold (typically an aggregate interference level not exceeding – 114.5dBm/MHz). The guideline system spacing for a randomly chosen PP link and SS antenna pointing direction will be large. For more reasonable distances, use must be made of antenna offsets or terrain and building losses or a combination of these and specific coordination is therefore usually required.

When the victim receiver is part of a multi-link PP system, the requirement for coordination will be reduced.

PP to SS, co-polar, co-channel case

In general, the victim receiver does not have “protected” status and so the system can be designed to give a low (but non – zero) probability of exceeding the interference threshold value.

When the interferer is a “protected” PP link, a relatively simple worst – case analysis of the interference can be carried out. The severity of the interference will depend on the PP link length. The probability of worst – case interference is generally low, since it only occurs when two highly directional antennas are aligned.

When the interferer is a multi- link PP system, a Monte Carlo analysis is more appropriate. This provides results indicating the probability of a range of interference values. The highest values are usually of very low probability and a view can be taken on a compromise system spacing that gives a low value of interference in most cases

BS to PP, same area, adjacent channel case

This scenario occurs where the victim PP receiver is operating in the same area as the interfering BS transmitter(s). Multiple interferers can occur when the PMP system has multiple cells/ sectors with a frequency reuse pattern. The BS-to-PP interference is not usually the worst case, but has a relatively high probability because of the wide beamwidth of a typical BS antenna.

When the PP link receiver has protected status, it is essential when planning the system to reduce this kind of interference below the required threshold (typically an aggregate interference level not exceeding – 114.5dBm/MHz). This usually requires some additional isolation over and above free space path loss. The isolation is normally achieved by using a “guard – band”, typically an integer multiple of the channel spacing of the system(s).

For typical guard – band/ isolation values, a significant proportion of the cell area may be unusable for the PP link station, unless use is made of antenna offsets or terrain and building losses or a combination of these. Specific coordination is usually required.

When the victim receiver is part of a multi-link PP system, the requirement for coordination will be reduced, since the victim system does not normally have “protected” status.

PP to BS, same area, adjacent channel case

In general, the victim receiver does not have “protected” status and so the system can be designed to give a low (but non – zero) probability of exceeding the interference threshold value.

When the interferer is a “protected” PP link, a relatively simple worst – case analysis of the interference can be carried out. The severity of the interference will depend on the PP link length, the distance from the BS and the amount of guard band isolation between the systems. Typically, satisfactory operation is possible except in an area close to the BS.

When the interferer is a multi- link PP system, satisfactory operation of the PP link station(s) will normally be possible, except in a small area close to the BS. The calculation can therefore be carried out in the same way as for the single PP case.

SS to PP, same area, adjacent channel case

This scenario occurs where the victim PP receiver is operating in the same area as the interfering SS transmitter(s). Multiple interferers can occur because the PMP cell has multiple subscribers. These may or may not transmit simultaneously, dependent on the systems design. The PMP system may also have multiple cells/ sectors with a frequency reuse pattern. The SS-to-PP interference is usually worse than the BS – PP case. The probability of interference from a single SS is low because both interferer and victim use narrow beam antennas. However, the potential for multiple interferers is significant. These may transmit simultaneously (in which case, the interference must be aggregated) or separately (in which case the probability of a given value of interference may increase).

When the PP link receiver has protected status, it is essential when planning the system to reduce this kind of interference below the required threshold (typically an aggregate interference level not exceeding – 114.5dBm/MHz). Interference can be reduced by physical spacing and guard band isolation, combined with antenna pointing restrictions.

When the victim receiver is part of a multi-link PP system, the requirement for coordination will be reduced, since the PP link receiver(s) do not have “protected” status.

PP to SS, same area, adjacent channel case

In general, the victim receiver does not have “protected” status and so the system can be designed to give a low (but non – zero) probability of exceeding the interference threshold value.

When the interferer is a single PP link, a relatively simple worst – case analysis of the interference can be carried out. The severity of the interference will depend on a number of factors including the PP link length, antenna orientation and guard band isolation. The probability of worst – case interference is generally low, since it only occurs when two highly directional antennas are aligned.

When the interferer is a multi- link PP system, a Monte Carlo analysis is more appropriate. This provides results indicating the probability of a range of interference values, for a given guard band isolation. The choice of guard band is a compromise that gives a low probability of interference in most cases, so that occasional coordination may be needed between PP link stations and SSs that have the worst alignment and are close together.

Mitigation techniques

[refer to relevant clauses in part 1 plus new section as follows:]

Impact of buildings on Mesh/PP to PMP co-channel interference

Mesh systems make use of terrain and buildings, combined with use of low transmit power and relatively short links, to reduce interference. The reduction in interference serves two functions:

it reduces internal interference, thus allowing increased frequency reuse and significantly improved spectral efficiency.

It reduces external interference, so that geographical spacing and guard bands can be reduced.

In this paper, the impact of buildings on coexistence of a mesh system is calculated, using a simulation tool. The simulator computes the cumulative interference from a mesh system into a victim receiver, which may be a PMP base station, PMP terminal station or a mesh node station. For the purposes of this document, only the most severe case (the PMP base station) is examined.

Since a mesh system is designed specifically to make use of buildings for reduction of interference, the model includes additional path losses due to buildings, using a methodology adapted from that used in the RAL CRABS report [4].

The impact of buildings is varied in the model by means of a parameter describing the distribution of building heights (Rayleigh parameter).

Simulation Methodology

The simulator computes the power received from a complete MP- MP system (mesh) at a PMP base station receiver, a PMP subscriber station receiver or other victim receiver, in a cell adjacent to the mesh. The

simulation is performed using a purpose-written program, which repeatedly constructs random (but adequately legitimate) MP-MP (mesh) systems and integrates the total power received at a given range and elevation, based on system, beam and terrain geometries.

A description of the simulation tool is provided in [] and will therefore not be repeated here.

The main analysis and all the results presented are based on systems operating in the 24- 28GHz band, but can be applied to any frequency up to at least 43.5GHz.

Interfering Power Calculation

From each mesh transmitter and in line with the line of sight probability, the power received by the victim base station is computed. All these powers are summed, and the result rounded to the nearest dBm and assigned to a histogram bin, so that the relative probability of each power level can be estimated.

Simulation Results

In order to assess the impact of different building heights, the parameters in the simulation tool were set as follows:

Frequency = 28 GHz

victim receiver = bases station with 90 degree sector antenna and 19dBi gain

distance from mesh edge to base station = 12km (any value can be set)

mesh link lengths from 50m to 1000m

mesh nodes placed 1m above roof height in all cases

mesh antenna gain = 25dBi

Rayleigh parameter (building height distribution) varying from zero to 20m

The only parameter varied between simulation runs was the Rayleigh parameter. This characterises the building height distribution curve, so that a value of zero would mean that there are no buildings, whilst a value of 20m would be a reasonable figure for a city. An example taken from real data, for the large city of Leeds in the UK, indicates a best –fit value of $R=40$.

Each simulation run was based on 10,000 trials, in which each trial represented a separate random mesh with 100 nodes per sq km. A cumulative distribution curve was produced for each run, showing the probability that the total interference received at the victim station was less than a particular value (x axis of the graph)

The results are shown in figure [x] .

Figure x

cumulative probability distributions

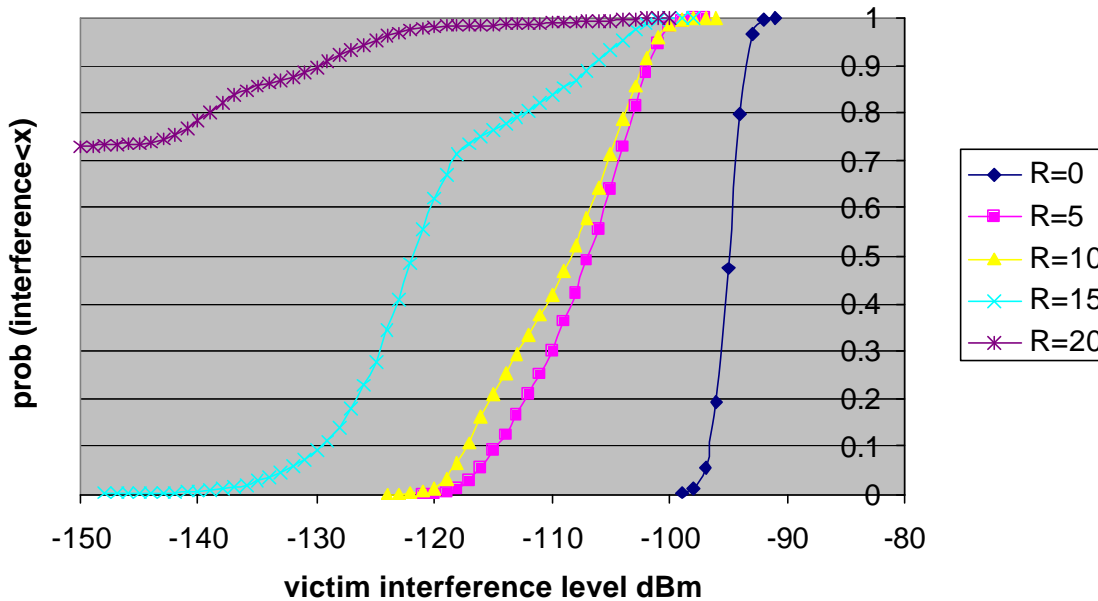

It can be seen that for all significant (non – zero) values of the Rayleigh parameter R, buildings have a significant impact on the level of interference. The target maximum level for interference is nominally –100dBm (-114.5dBm/ MHz).

For values of R in the range 5<R<20 the proportion of the random meshes that exceed the threshold is very small, so the 12 km spacing is likely to be a reasonable value in the great majority of deployments.

For the case where there are no buildings, the highest value is 7-8 dB above the threshold, so that a wider spacing would then be required. However, a mesh would not be deployed when there are no buildings on which to mount nodes. This scenario is therefore highly pessimistic and an unrealistic representation of real deployments.

Conclusions

Buildings have a significant and extremely useful effect on interference from a mesh system, reducing the required co- channel system spacing by a factor of approximately 2. This effect does not rely on the use of any additional mitigation technique and is derived from a simple assumption that all mesh layouts are random. Even relatively low buildings are effective in reducing interference, because mesh nodes are placed at or near building height rather than on tall masts.

Even with no buildings, the co-channel spacing is similar to or less than that recommended for PMP systems in SE19 report [3].

Annex 2A (informative)

Test and measurement/ hardware parameter summary

? anything to add to Annex (1)A

Annex 2B (informative)***Psfd calculations***

?add 38 GHz calculation. Otherwise refer to Annex (1)B

Annex2C (informative)***Description of calculations and simulation methods***

[See separate document; to be reviewed and added to main text]

Editorial instruction: Add complete new section (part 3) as follows [starts at Part 3 heading and ends attba]

Part 3: Coexistence of Fixed Broadband Wireless Access Systems operating in frequency range 1; 2-11 GHz***Overview of section***

This section contains guidelines and recommendations for coexistence between various types of FBWA systems, operating in the frequency range 2-11 GHz. Because of the wide frequency range and variety of system types, three sets of results have been derived, covering operating frequencies around 2.5 GHz, 3.5 GHz and 10.5 GHz. The guidelines and recommendations are supported by the results of a large number of simulations or representative interference cases. The full details of the simulation work are contained in input documents, referenced in section [4.] This section lists the full set of archived input documents used in the preparation of this document and in the preparation of the published recommended practice.

Scope statement (summary of what scenarios have been studied – derived from PAR)

Part 3 of this Recommended Practice defines a set of consistent design and deployment recommendations that promote coexistence for fixed BWA systems that share the same bands within the frequency range 2-11GHz. The recommendations, if followed by manufacturers and operators, will facilitate a wide range of equipment to coexist in a shared environment with acceptable mutual interference.

The scope of this Part 3 of the Recommended Practice includes the examination of interference between systems deployed across geographic boundaries in the same frequency blocks and systems deployed in the same geographic area in adjacent frequency blocks.

This document is not intended to be a replacement for applicable regulations, which would take precedence.

Document philosophy [revise heading]

As noted in Part 1, radio waves permeate through legislated (and even national) boundaries and emissions spill outside spectrum allocations. Coexistence issues between multiple operators are therefore inevitable. The resolution of coexistence issues is an important factor for the fixed BWA industry. The Recommendations in [4.2] are provided for consideration by operators, manufacturers, and administrations to promote coexistence. Practical implementation within the scope of the current recommendations will assume that some portion of the frequency spectrum (at the edge of the authorized bandwidth) may be unusable. Furthermore, some locations within the service area may not be usable for deployment. Coexistence will rely heavily on the good-faith collaboration between spectrum holders to find and implement economical solutions. The document analyzes coexistence using two scenarios:

- A co-channel (CoCh) scenario in which two operators are in either adjacent territories or territories within radio line of sight of each other and have the same spectrum allocation, and
- An adjacent Channel (AdjCh) scenario in which the licensed territories of two operators overlap and they are assigned adjacent spectrum allocations.

Coexistence issues may arise simultaneously from both scenarios as well as from these scenarios involving multiple operators. As a starting point for the consideration of tolerable levels of interference into fixed BWA systems, ITU-R Recommendation F.758-2 [B16] details two generally accepted values for the interference-to-thermal noise ratio (I/N) for long-term interference into fixed service receivers. When considering interference from other services, it identifies an I/N value of -6dB or -10dB matched to specific requirements of individual systems. This approach provides a method for defining a tolerable limit that is independent of most characteristics of the victim receiver, apart from noise figure, and has been adopted for this Recommended Practice. The acceptability of any I/N value needs to be evaluated against the statistical nature of the interference environment. In arriving at the Recommendations in this document this evaluation has been carried out for an I/N value of -6 dB.

Clause 9 provides interference mitigation measures that can be utilized to solve coexistence problems. Because of the wide variation in subscriber station and base station distribution, radio emitter/receiver parameters, localized rain patterns, and the statistics of overlapping emissions in frequency and time, it is impossible to prescribe in this document which of the mitigation measures are appropriate to resolving a particular coexistence problem. In the application of these mitigation measures, identification of individual terminals or groups of terminals for modification is preferable to the imposition of pervasive restrictions.

Implementing the measures suggested in Recommendations 8CE10 in 4.2 using the suggested equipment parameters in Clause 6 will, besides improving the coexistence conditions, have a generally positive effect on intrasystem performance. Similarly, simulations performed in the preparation of this Recommended Practice suggest that most of the measures undertaken by an operator to promote intrasystem performance will also promote coexistence. It is outside the scope of this document to make recommendations that touch on intrasystem matters such as frequency plans, frequency reuse patterns, etc.

Recommendations and Guidelines, including indicative geographical and physical spacing between systems.

Recommendations

[review/ edit the following recommendations]

Recommendation 1

Adopt a criterion of 6 dB below receiver thermal noise (i.e., $I/N \leq -6$ dB) in the victim receiver as an acceptable level of interference from a transmission of an operator in a neighboring area. The document recommends this value in recognition of the fact that it is not practical to insist upon an interference-free environment. Having once adopted this value, the following are some important consequences: -Each operator accepts a 1 dB degradation [the difference in dB between C/N and $C/(N + I)$] in receiver sensitivity. In some regard, an I/N of ≤ -6 dB becomes the fundamental criterion for coexistence. The very nature of the MP system is that receivers must accept interference from intrasystem transmitters. Although a good practice would be to reduce the intrasystem interference level to be well below the thermal noise level (see Recommendation 6 in 4.2.6), this is not always feasible. The actual level of external interference could be higher than the limit stated above and still be not controlling, or comparable to the operator's intrasystem interference. Thus, there is some degree of interference allocation that could be used to alleviate the coexistence problem.

- Depending upon the particular deployment environment, an operator's receiver may have interference contributions from multiple CoCh and AdjCh operators. Each operator should include design margin capable of simultaneously accepting the compound effect of interference from all other relevant operators. The design margin should be included preemptively at initial deployment, even if the operator in question is the first to deploy in a region and is not experiencing interference.

All parties should recognize that, in predicting signal levels that result in the ≤ -6 dB interference value, it is difficult to be precise in including the aggregating effect of multiple terminals, the effect of uncorrelated rain, etc. Therefore, all parties should be prepared to investigate claims of interference even if the particular assessment method used to substantiate the ≤ -6 dB value predicts that there should not be any interference.

Recommendation 2

Each operator should take the initiative to collaborate with other known operators prior to initial deployment and prior to every relevant system modification. This recommendation should be followed even if an operator is the first to deploy in a region. To encourage this behavior for co-channel interference, this document introduces the concept of using power spectral flux density values to "trigger" different levels of initiatives taken by an operator to give notification to other operators. The specific trigger values and their application to the two deployment scenarios are discussed in Recommendation 5 (4.2.5) and Recommendation 6 (4.2.6) and in Clause 7

Recommendation 3

In the resolution of coexistence issues, in principle, incumbents and first movers should coordinate with operators who deploy at a later time. In resolving coexistence issues, it is legitimate to weigh the capital investment an incumbent operator has made in his or her system. It is also legitimate to weigh the capital investment required by an incumbent operator for a change due to coexistence versus the capital investment costs that the new operator will incur. The logic behind this Recommendation is that some coexistence problems cannot be resolved simply by modifying the system of a new entrant into a region. Rather, they require the willingness of an incumbent to make modifications as well. It is recognized that this Recommendation is especially challenging in the AdjCh scenario

where overlapping territories imply that the incumbent and the late-comer may be competing for the same clients. The reality of some spectrum allocations are such that AdjCh operators will be allocated side-by-side frequency channels. As is seen below, this is an especially difficult coexistence problem to resolve without co-location of the operator's cell sites.

Recommendation 4

No coordination is needed in a given direction if the transmitter is greater than 60 km from either the service area boundary or the neighbor's boundary (if known) in that direction. Based on typical fixed BWA equipment parameters and an allowance for potential LOS interference couplings, subsequent analysis indicates that a 60 km boundary distance is sufficient to preclude the need for coordination. At lesser distances, coordination may be required, but this is subject to a detailed examination of the specific transmission path details that may provide for interference link excess loss or blockage. This coordination criteria is viewed to be necessary and appropriate for both systems that conform to this Recommended Practice and those that do not.

Recommendation 5

(This Recommendation applies to co-channel cases only.) Recommendation 2 above introduced the concept of using power spectral flux density "triggers" as a stimulus for an operator to take certain initiatives to collaborate with his or her neighbor. It is recommended that regulators specify the applicable trigger values for each frequency band, failing which the following values may be adopted: The coordination trigger values (see Annex B) of ≤ 114 (dBW/m²)/MHz (24, 26, and 28 GHz bands) and ≤ 111 (dBW/m²)/MHz (38 and 42 GHz bands) are employed in the initiative procedure described in Recommendation 6 (4.2.6). The evaluation point for the trigger exceedance may be at either the victim operator's licensed area boundary, the interfering operator's boundary, or at a defined point in between depending to some extent on the specific geographic circumstances of the BWA licensing. These values were derived as that power spectral flux density values which, if present at a typical point-to-multipoint base station antenna and typical receiver, would result in approximately the ≤ 6 dB interference value cited in Recommendation 1. It should be emphasized that the trigger values are useful only as thresholds for taking certain actions with other operators; they do not make an absolute statement as to whether there is, or is not, interference potential. In cases of significant deployment of point-to-point systems alongside point-to-multipoint systems where protection of the point-to-point systems is mandated, tighter psfd trigger levels may be appropriate. For example, ≤ 125 (dBW/m²)/MHz at 38 GHz band is applied by some administrations to protect point-to-point links.

Recommendation 6

(This Recommendation applies to co-channel cases only.)

The "triggers" of Recommendation 5 and Recommendation 6 should be applied prior to deployment and prior to each relevant system modification. Should the trigger values be exceeded, the operator should try to modify the deployment to meet the trigger or, failing this, the operator should coordinate with the affected operator. Three existing coordination procedures are described in D, E, and F.

Recommendation 7

For same area/adjacent channel interference cases, analysis and simulation indicate that deployment may require an equivalent guard frequency between systems operating in close proximity and in adjacent frequency blocks. It is convenient to think of the "guard frequency" in terms of "equivalent channels" related to the systems operating at the edges of the neighboring frequency blocks. The amount of guard frequency depends on a variety of factors such as "out of block" emission levels and in some cases is linked to the probability of interference in given deployment scenarios. Clause 8 provides insight into some methods that can be employed to assess these situations, while Clause 9 describes some possible interference mitigation techniques. These mitigation techniques include frequency guard bands, recognition of cross-polarization differences, antenna angular

discrimination, spatial location differences, and frequency assignment substitution. In most co-polarized cases, where the transmissions in each block are employing the same channel bandwidth, the guard frequency should be equal to one equivalent channel. Where the transmissions in neighboring blocks employ significantly different channel bandwidths, it is likely that a guard frequency equal to one equivalent channel of the widest bandwidth system will be adequate. However, analysis suggests that, under certain deployment circumstances, this may not offer sufficient protection and that a guard frequency equal to one channel at the edge of each operator's block may be required. Where administrations do not set aside guard channels, the affected operators would need to reach agreement on how the guard channel is apportioned between them. It is possible that, with careful and intelligent frequency planning, coordination, and/or use of orthogonal polarization or other mitigation techniques, all or partial use of this guard channel may be achieved. However, in order to minimize interference conflicts and at the same time maximize spectrum utilization, cooperative deployment between operators will be essential. This recommendation strongly proposes this.

Recommendation 8

Utilize antennas for the base station and subscriber stations at least as good as the Class 1 antennas described in 6.2. The coexistence simulations which led to the Recommendations contained herein revealed that a majority of coexistence problems are the result of main-beam interference. The sidelobe levels of the base station antennas are of a significant but secondary influence. The sidelobe levels of the subscriber antenna are of tertiary importance. In the context of coexistence, therefore, antennas such as those presented in 6.2 are sufficient. It should be emphasized that utilizing antennas with sidelobe (and polarization) performance better than the minimum will not degrade the coexistence performance and, in fact, is an effective mitigation technique for specific instances. In many cases, intrasystem considerations may place higher demands on antenna performance than those required for intersystem coordination.

Recommendation 9

Utilize an emission mask at least as good as that described in 6.1.3. The utility of emission masks for controlling adjacent channel coexistence issues is strongly dependent upon the separation of the two emitters in space and in frequency. In case of large spatial separation between emitters, the opportunity exists for an interfering emitter to be much closer to a receiver than the desired emitter. This unfavorable range differential can overwhelm even the best emission mask. Likewise, emission masks are most effective when at least one guard channel exists between allocations. The emission mask presented in 6.1.3 is most appropriate for the case in which a guard channel separates allocations and emitters are modestly separated. For cases with no guard band, it is recommended that co-location of harmonized base station emitters be considered before trying to improve emission masks.

Recommendation 10

Limit maximum EIRP in accordance with recommendations in 6.1.1 and use SS power control in accordance with recommendations in 6.1.1.5. The interests of coexistence are served by reducing the amount of EIRP emitted by base, SS, and repeater stations. The proposed maximum EIRP spectral density values are significantly less than allowed by some regulatory agencies but should be an appropriate balance between constructing robust fixed BWA systems and promoting coexistence.

Recommendation 11

In conducting analyses to predict power spectral flux density and for coordination purposes, the following should be considered:

- a) Calculations of path loss to a point on the border should consider:
 - 1) Clear air (no rain) plus relevant atmospheric absorption
 - 2) Intervening terrain blockage

b) For the purpose of calculating psfd trigger compliance level, the psfd level at the service area boundary should be the maximum value which occurs at some elevation point up to 500 m above local terrain elevation. Equations (B.2) and (B.3) in Annex B should be used to calculate the psfd limits.

c) Actual electrical parameters (e.g., EIRP, antenna patterns, etc.) should be used.

d) Clear sky propagation (maximum path length) conditions should be assumed. Where possible, use established ITU-R Recommendations relating to propagation (e.g., Recommendation ITU-R P.452 [B20]).

Suggested guidelines for geographical and frequency spacing

This subclause and Clause [8] indicate some of the models, simulations, and analysis used in the preparation of this Recommended Practice. While a variety of tools may be used, the scenarios studied below should be considered when coordination is required. Guidelines for geographical and frequency spacing of fixed BWA systems that would otherwise mutually interfere are given in [8.1] for each of a number of interfering mechanisms. This subclause summarizes the overall guidelines, taking into account all the identified interference mechanisms. The two main deployment scenarios are as follows:

- Co-channel systems that are geographically spaced
- Systems that overlap in coverage and (in general) require different frequencies of operation

The most severe of the several mechanisms that apply to each case determines the guideline spacing, as shown in Table 1: [delete colon?]

[Edit/ delete? The guidelines are not meant to replace the coordination process described in Clause 7. However, in many (probably most) cases, these guidelines will provide satisfactory psfd levels at system boundaries. The information is therefore valuable as a first step in planning the deployment of systems.]

System overview

[review/ edit this section]

BWA generally refers to fixed radio systems used primarily to convey broadband services between users’ premises and core networks. The term “broadband” is usually taken to mean the capability to deliver significant bandwidth to each user. In ITU terminology, and in this document, broadband transmission refers to transmission rate of greater than around 1.5 Mbit/s, though many BWA networks support significantly

Table [1] Summary of the guidelines for geographical and frequency spacing

Dominant interference path(note 1)	Scenario	Spacing at which interference is below target level (generally 6 dB below receiver noise floor)
PMP BS to PMP BS	3.5 GHz; Adjacent area, same channel	

Mesh SSs to PMP BS	3.5 GHz; Adjacent area, same channel	[no contributions for low frequency mesh?]
PMP BS to PMP BS	3.5 GHz; Same area, adjacent channel	
Mesh SSs to PMP SS	3.5 GHz; Same area, adjacent channel	[no contributions for low frequency mesh?]
PMP BS to PMP BS	10.5 GHz; Adjacent area, same channel	
Mesh SSs to PMP BS	10.5 GHz; Adjacent area, same channel	[no contributions for low frequency mesh?]
PMP BS to PMP BS	10.5 GHz; Same area, adjacent channel	
Mesh SSs to PMP SS	10.5 GHz; Same area, adjacent channel	[no contributions for low frequency mesh?]
Notes:		

higher data rates. The networks operate transparently, so users are not aware that services are delivered by radio. A typical fixed BWA network supports connection to many user premises within a radio coverage area. It provides a pool of bandwidth, shared automatically among the users. Demand from different users is often statistically of low correlation, allowing the network to deliver significant bandwidth-on-demand to many users with a high level of spectrum efficiency. Significant frequency reuse is employed.

The range of applications is very wide and evolving quickly. It includes voice, data, and entertainment services of many kinds. Each subscriber may require a different mix of services; this mix is likely to change rapidly as connections are established and terminated. Traffic flow may be unidirectional, asymmetrical, or symmetrical, again changing with time. In some territories, systems delivering these services are referred to as multimedia wireless systems (MWS) in order to reflect the convergence between traditional telecommunications services and entertainment services.

These radio systems compete with other wired and wireless delivery means for the “first mile” connection to services. Use of radio or wireless techniques result in a number of benefits, including rapid deployment and relatively low “up-front” costs.

System architecture

[review/ edit this section]

Fixed BWA systems often employ multipoint architectures. The term multipoint includes point-to-multipoint (PMP) and multipoint-to-multipoint (MP-MP). The IEEE 802.16 Working Group on Broadband Wireless Access (see Clause 2) is developing standards for PMP systems with base stations and subscriber stations communicating over a fully specified air interface. A similar PMP standard is being developed within the “HIPERACCESS” topic within ETSI Project BRAN 7. Coexistence specifications for MWS (which includes

PMP Systems

[old part 1 text OK?]

MP systems (Mesh)

[old part 1 text OK?]

System components

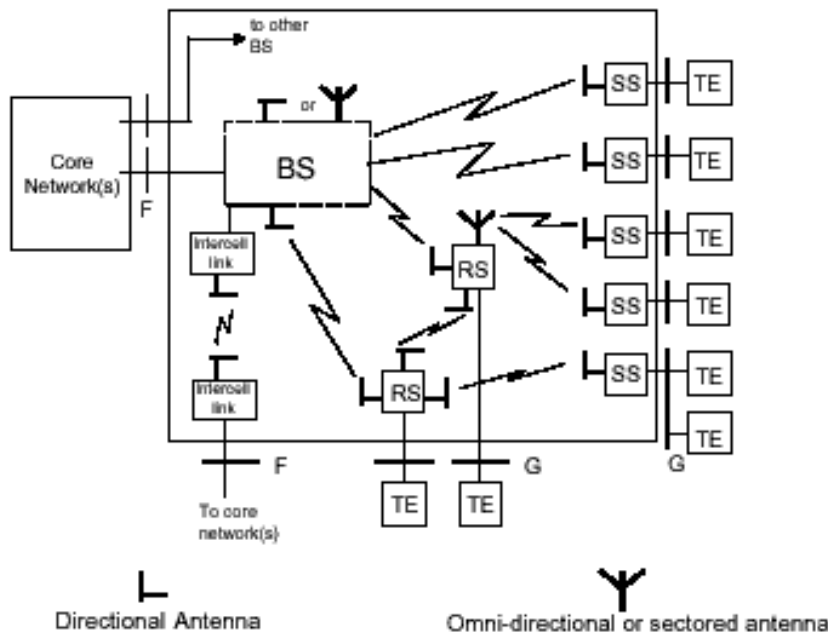

SOURCE: ETSI 301 390 v1.1.1 (2000 – 12) [is this the correct reference – it seems to be a diagram from the 40 GHz MWS specification?]

Figure [1] – Interference Sources to a fixed BWA BS [Review this title – it is really a reference diagram]

System description (interferer and victim systems)

Description of system interference scenarios

[new text to be written]

(e.g. line of sight systems, lower frequency systems operating with path obstructions, external systems such as satellites)

System parameters assumed in the simulations

The system parameters assumed in the simulations are based on the data in document IEEE 802.16.2a-01/12 []

Table []: circa. 2.5 GHz systems with a cellular architecture.

Characteristic (cellular systems)	Examples
-----------------------------------	----------

Layout of system(s) including diagrams	Multi – cell (uniformly distributed), (variable cell sizes including “super cell”) Block diagrams needed
Typical sector arrangements and frequencies	Typically 4-sectors per cell, 4 frequencies, V and H polarization both used; . Some systems will use adaptive antennas, pointing at users. TDD Transmitter diversity may be used (base stations only). FDD also used
Propagation	Partly obstructed paths allowed (channel model available 802.16.3c01_29r2) For coexistence purposes, assume free space loss up to a distance of (tba) and beyond that use best fit curve from measured results (JC to produce a typical formula for a best fit curve).[3]. Rain fading assumptions – negligible. Atmospheric multipath fading not considered
Cell size	Up to 45km radius
Availability objective	99.9 – 99.99% of time for 80 – 90% cell area coverage
Number of cells in a system	1 to 25 (typical range)
Number of terminal stations per MHz per T/R per cell	Up to 70
Distribution of terminal stations	Uniform per unit area.
Frequency of operation (for each variant to be studied)	2.15 -2.162, 2.305 – 2.32/ 2.345 – 2.360 and 2.50 to 2.69 GHz. Use 2.6 GHz for coexistence calculations.
Duplex method	TDD, FDD, Half duplex
Receiver parameters	
Channel bandwidth	1.5/3/6/12/25 MHz (N. America) 1.75/3.5/7/14 MHz (Europe). Use 6 MHz for coexistence calculations.
filter response	Root Nyquist with 25% roll off factor assumed
noise floor	4dB noise figure upstream 5dB noise figure downstream
acceptable level for co-channel interference	I/N = –6dB (aggregate of all interferers)
Transmitter parameters	
Channel bandwidth	1.5/3/6/12/25 MHz (N. America) 1.75/3.5/7/14 MHz (Europe) Use 6 MHz for coexistence calculations.
Emission mask	See figures 6 and 7 of IEEE 802.16ab-01/01.
Maximum eirp	2000W eirp at base station or subscriber

Typical transmitter power	(100W at base station, 1W at subscriber)
use of ATPC, steps and range (typical) Tx-Rx parameters	Uplink only, 2dB steps, 50dB range NFD (net filter discrimination; call for contributions to be posted for real measurements or values calculated by numerical integration) (use TM4 values or calculate, in the absence of any other sources of data)
Antenna characteristics (base station, typical)	Use ETSI RPE for 90 degree sector Gain = 16 dBi [RW to investigate whether this is practical]
Antenna characteristics (subscriber station, typical)	Use ETSI RPE Gain = 16dBi; hpbw 25 degrees Some systems may use omni with 2dB gain.
Antenna characteristics (repeater station)	Assume same as BS and SS
Backhaul links	Separate frequency assignments

Table []: 3.5 GHz systems with a cellular architecture.

Characteristic (cellular systems)	Examples
Layout of system(s) including diagrams	Multi – cell (uniformly distributed), (variable cell sizes) Block diagrams needed [1]
Typical sector arrangements and frequencies	Typically 4-sectors per cell, 4 frequencies, V and H polarization both used [1]; Some systems will use adaptive antennas, pointing at individual users. FDD and TDD used
Propagation	Partly obstructed paths allowed (channel model available 802.16.3c01_29r2, subject to formal adoption. For coexistence purposes use line of sight loss up to 15km, then d^4 beyond that point [2] Rain fading assumptions – negligible. Atmospheric multipath ignored on interfering paths.
Cell size	Typically 7km
Availability objective	99.9 – 99.99% of time for 80 – 90% cell area coverage
Number of cells in a system	1 to 25 (typical range)
Number of terminal stations per MHz per T/R per cell	Up to 70
Distribution of terminal stations	Uniform per unit area.
Frequency of operation (for each variant to be studied)	3.4 to 3.8 GHz (use 3.6 GHz for coexistence calculations)

Duplex method	TDD, FDD, Half duplex
Receiver parameters Channel bandwidth	1.5/3/6/12/25 MHz (N. America) 1.75/3.5/7/14 MHz (Europe) (use 7 MHz for coexistence calculations)
filter response	Root Nyquist with 25% roll off factor assumed
noise floor	4dB noise figure upstream 5dB noise figure downstream
Acceptable level for co-channel interference	I/N = -6dB (aggregate of all interferers)
Transmitter parameters	
Channel bandwidth	1.5/3/6/12/25 MHz (N. America) 1.75/3.5/7/14 MHz (Europe) (use 7 MHz for coexistence calculations)
emission mask	See figures 4 and 5 of IEEE 802.16ab-01/01
Maximum eirp	Tba
typical transmitter power use of ATPC, steps and range	(3W at base station, 1W at subscriber) Uplink only, 2dB steps, 40dB range
Tx-Rx parameters	NFD (net filter discrimination; call for contributions to be posted for real measurements or values calculated by numerical integration) (use TM4 values or calculate, in the absence of any other sources of data)
Antenna characteristics (base station)	Use ETSI RPE for 90 degree sector Gain = 14.5 dBi
Antenna characteristics (subscriber station)	Use ETSI RPE Gain = 18dBi – note 3
Antenna characteristics (repeater station)	Assume same as BS and SS
Backhaul links	Separate frequency assignments

Table []: 10.5 GHz systems with a cellular architecture.

Characteristic (cellular systems)	Examples
Layout of system(s) including diagrams	Multi – cell (uniformly distributed), (variable cell sizes)
Typical sector arrangements and frequencies	Typically 4-sectors per cell, 4 frequencies, V and H polarization.
Propagation	Line of sight paths only [3]. . Rain fading important – ITU equations to be used. Atmospheric multipath fading ignored for coexistence purposes
Cell size	Typically 7km

Availability objective	99.9 – 99.99% of time for approx. 50% cell area coverage
Number of cells in a system	1 to 25 (typical range)
Number of terminal stations per MHz per T/R per cell	70
Distribution of terminal stations	Uniform per unit area.
Frequency of operation (for each variant to be studied)	10.5 to 10.68 GHz
Duplex method	TDD, FDD, Half duplex
Receiver parameters	
Channel bandwidth	3/6/12/25 MHz (N. America) 3.5/7/14 MHz (Europe) Use 7 MHz for coexistence calculations
filter response	Root Nyquist with 25% roll off factor assumed
noise floor	6dB noise figure
Acceptable level for co-channel interference	I/N = –6dB (aggregate of all interferers)
Transmitter parameters	
Channel bandwidth	3/6/12/25 MHz (N. America) 3.5/7/14 MHz (Europe) Use 7 MHz for coexistence calculations
emission mask	Not defined (use ETSI for the purpose of calculating NFD)
Maximum power	TBA
typical power	(1W at base station, ???1W at subscriber)
use of ATPC, steps and range	Uplink only, 2dB steps, 40dB range
Tx-Rx parameters	NFD (net filter discrimination; call for contributions needed) (use TM4 values or calculate, in the absence of any other source of data).
Antenna characteristics (base station)	Use ETSI RPE for 90 degree sector Gain = tba ???16 dBi (RW will research PW to remind RW).
Antenna characteristics (subscriber station)	Use ETSI RPE Gain = 25 dBi (GJG and RW will research)
Antenna characteristics (repeater station)	TBA
Backhaul links	Separate frequency assignments

Typical antenna characteristics

Medium Overview

[new text required or edit previous from part 1?]

Interference Scenarios

[new text required or edit previous from part 1?]

Forms of Interference

Acceptable level of interference

Interference paths

Victim BS

Victim subscriber station

Equipment design Parameters

Transmitter design parameters

[new text required or edit previous from part 1?]

Maximum EIRP spectral density limits

Base station

Subscriber station

Repeater station

In – band intercell links

Uplink power control

Downlink power control

Frequency tolerance or stability

Out – of – block unwanted emissions

Antenna parameters

[in absence of input, we can only state our assumptions in the various simulations]

Receiver design parameters

[new text required or edit previous from part 1?]

Deployment and coordination

[new text required or edit previous from part 1?]

Co frequency, adjacent area

[edit part 1 text?]

Same area/ adjacent frequency

[edit text from part 1?]

Use of power spectral flux density (psfd) as a coexistence metric

[new text or delete – no contributions for lower frequencies?]

Deployment procedure

[edit text from part 1?]

Interference and propagation evaluation/ examples of coexistence in a PMP environment

Guidelines for geographical and frequency spacing between fixed BWA systems

[new text needed or edited version of that in part 1, plus table to be reviewed and edited]

	Scenario	Frequency	Area/ channel	Guideline spacing	Methodology
18	BS – SS	2.5 GHz	Adjacent area, same channel	No contributions	
19	SS – BS	2.5 GHz	Adjacent area, same channel	No contributions	
20	SS – SS	2.5 GHz	Adjacent area, same channel	No contributions	
21	BS – BS	2.5 GHz	Same area, adjacent channel	No contributions	
22	BS – SS	2.5 GHz	Same area, adjacent channel	No contributions	
23	SS – BS	2.5 GHz	Same area, adjacent channel	No contributions	
24	SS – SS	2.5 GHz	Same area, adjacent channel	No contributions	
25	BS – BS	3.5 GHz	Adjacent area, same channel	review meeting #19	Worst case analysis
26	BS – SS	3.5 GHz	Adjacent area, same channel	Review meeting #19	Worst case analysis
27	SS – BS	3.5 GHz	Adjacent area, same channel	Typically 60 – 80 km spacing needed	Monte Carlo analysis
28	SS– SS	3.5 GHz	Adjacent area, same channel	Low probability. Coordination needed for the bad cases.	N/A

29	BS – BS	3.5 GHz	Same area, adjacent channel	Combination of isolation (NFD etc) and physical spacing is required (typically 0.1 – 2km, dependent on available isolation)	Monte Carlo analysis
30	BS – SS	3.5 GHz	Same area, adjacent channel	Isolation needed (NFD etc) depends on modulation. In some cases it may be possible to operate in the adjacent channel.	Monte Carlo analysis
31	SS – BS	3.5 GHz	Same area, adjacent channel	Isolation needed (NFD etc) depends on modulation. In some cases it may be possible to operate in the adjacent channel.	Monte Carlo analysis
32	SS – SS	3.5 GHz	Same area, adjacent channel	Low/ medium probability Coordination needed for the bad cases.	TBA
33	BS – BS	10.5 GHz	Adjacent area, same channel	Tba	
34	BS – SS	10.5 GHz	Adjacent area, same channel	Tba	
35	SS – BS	10.5 GHz	Adjacent area, same channel	Typically 60 – 80 km spacing required	Monte Carlo analysis
36	SS – SS	10.5 GHz	Adjacent area, same channel	Tba	
37	BS – BS	10.5 GHz	Same area, adjacent	Tba	
38	BS – SS	10.5 GHz	Same area, adjacent	Tba	
39	SS – BS	10.5 GHz	Same area, adjacent	Tba	
40	SS – SS	10.5 GHz	Same area, adjacent	Tba	

Mitigation techniques

[new text or edit from part 1?]

Annex 3A**Test and measurement/ hardware parameter summary**

[edit text from part 1 or delete?]

Annex 3B**Power spectral flux density (psfd) calculations**

[revise text and calculations from part 1, so as to be appropriate for lower frequencies?]

Annex 3C

(Informative)

Description of calculations and simulation methods

[short summary text to be added]

Description of simulations – 2.5 GHz

[simulation results not yet available]

Methodology**Outline results from each simulation****Description of simulations – 3.5 GHz**

[simulation work for the co-channel adjacent area TS to CS scenario has been undertaken by GJG. The contribution is being updated. When the contribution is updated it will be pasted into this section, for subsequent editing].

[Provisional conclusion; The probability of receiving unacceptable interference is relatively high for all the propagation models used in the simulations. Therefore, the recommended co – channel system spacing will be of the order of 60km (over the horizon in most cases)]

Methodology**Outline results from each simulation****Description of simulations – 10.5 GHz**

[simulation work for the co-channel adjacent area TS to CS scenario has been undertaken by GJG. The contributions are being updated. When the contributions have been updated they will be pasted into this section, for subsequent editing].

[Provisional conclusion; The probability of receiving unacceptable interference is relatively high for all the propagation models used in the simulations. Therefore, the recommended co – channel system spacing will be of the order of 60km (over the horizon in most cases)]

Annex 3D

Work of other bodies

[no references so far?]

Annex 3E

UK Radiocommunications Agency coordination process

[none available for lower frequencies; delete?]

Annex 3F

Industry Canada coordination process

[none available for lower frequencies; delete?]

Editorial instruction: add new annex of references to complete simulation analysis:

Annex [] Bibliography of references to complete simulation analysis

This list includes references for all relevant contributions to the simulation work for all parts of the amended recommended practice, including those relating to the document published in September 2001. The source documents may be found in the current 802.16 directory or in the archive.

[add refs. It may be useful to do this in tabular form, including a brief abstract of each simulation contribution]

Simulations and related documents used in the compilation of Part 1

[to be reviewed and completed]

[] ERC Report; “SE19 Report on the analysis of the coexistence of two FWA cells in the 24.5-29.5GHz bands”.

Simulations and related documents used in the compilation of Part 2

[to be reviewed and completed]

[] IEEE C802.16.2a-01/06: “System parameters for point to point links for use in Coexistence Simulations (revision 1)” (Philip Whitehead, 01/09/13)

[] IEEE C802.16.2a-02/22; “Interference from a BFWA PMP system to a multi-link PP system (co-channel case; frequency range 2: 23.5 to 43.5 GHz)” (Philip Whitehead, 02/04/24)

[] IEEE C802.16.2a-02/21; “Interference from a BFWA PMP system to a PP link system (co-channel case; frequency range 2: 23.5 to 43.5 GHz)” (Philip Whitehead, 02/04/24)

[] IEEE C802.16.2a-02/20; “Interference from a BFWA PMP system to a PP link system (same area, adjacent channel case)” (Philip Whitehead, 02/04/24)

[] IEEE C802.16.2a-02/19; “Interference from a PP link system to a BFWA PMP system (same area, adjacent channel case)” (Philip Whitehead, 02/04/24)

[] IEEE C802.16.2a-02/18; “Interference from a BFWA PMP system to a multi-link PP system (co-channel case; frequency range 2: 23.5 to 43.5 GHz)” (Philip Whitehead, 02/04/23)

[] IEEE C802.16.2a-01/15r1; “Distance Resulting in a -100 dBm Interference Level into a 25 GHz PTP Receiver from a 25 GHz PTMP Transmitter” (Rémi Chayer, 01/09/13)

[] IEEE C802.16.2a-01/11

Simulation data (point to point links interfering with PMP systems) (Philip Whitehead, 01/10/30)

[] IEEE C802.16.2a-01/10; “Interference between a PMP system and a multi-link PP system (same area, adjacent channel case)” (Philip Whitehead, 01/10/30)

[] IEEE C802.16.2a-01/09; “Coexistence between point to point links and PMP systems (revision 1)” (Philip Whitehead, 01/10/30)

[] IEEE C802.16.2a-01/04; “Simulation data (point to point links interfering with PMP systems)” (Philip Whitehead, 01/09/13)

[] IEEE C802.16.2a-01/03; “Impact of buildings on Mesh/PP to PMP Co-channel Interference” (Philip Whitehead, 01/09/04)

[] IEEE C802.16.2a-01/02; “Coexistence between point to point links and PMP systems” (Philip Whitehead, 01/08/30)

[] IEEE 802.16.2-01/14; “Proposed Antenna Radiation Pattern Envelopes for Coexistence Study” (Robert Whiting, 01/07/12)

2002-05-10

IEEE C802.16.2a-02/27

- [] IEEE802.16c-01/03r1; “Amendments for Coexistence of High Density Fixed Systems (HDFS) Point-to-Multipoint (PMP), Point-to-Point (PTP) and Mesh Systems” (Reza Arefi, Peter A. Soltesz, and Fred Ricci, 01/03/08)
- [] IEEE 802.16.2p-00/13: “Coexistence analysis at 26 GHz and 28 GHz” (This paper contains an explanation of NFD and provides NFD values derived from an ETSI report)
- [] IEEE C802.16-2a-01/03; “Impact of buildings on Mesh/ PP to PMP co-channel interference”; Philip Whitehead
- [] IEEE C802.16-2a-01/04: “Simulation data (point to point links interfering with PMP systems)”; Philip Whitehead
- [] ACTS Project 215, Deliverable Report D3P1B; Cellular Radio Access for Broadband Services (CRABS)
- [] ITU-R P.838; “Specific attenuation model for rain for use in prediction methods”
- [] ITU-R P.452-8; “Prediction procedure for ... microwave interference ...”
- [] ITU-R P.676-3; Atmospheric attenuation
- [] ITU-R P.840-2; Rain attenuation
- [] ETSI EN 301 215-2,V1.1.1; “Antennas for use in PMP systems (24GHz to 30GHz)”
- [] ETSI EN 301 213-3,V1.1.1; “Transmitter characteristics for TDMA PMP systems”
- [] IEEE 802.16.2; “Recommended Practice for Coexistence of Fixed Broadband Wireless Systems”
- [] IEEE 802.16.2-01/14; “Proposed Antenna Radiation Pattern Envelopes for Coexistence Study” by Robert Whiting, 01/07/12
- [] IEEE 802.16.2-01/12; “System parameters for point to point links for use in Coexistence Simulations”; Phil Whitehead, 01/07/12

Simulations and related documents used in the compilation of Part 3

[to be reviewed and completed]

- [] IEEE 802.16c-01/02; Coexistence studies for frequencies below 11GHz and with point to point links; Philip Whitehead
- [] IEEE C802.16.2a-02/23; “Coexistence Same Area C/I Simulation Estimates at 10.5 GHz (CS to CS)” (G. Jack Garrison, 02/04/25)
- [] IEEE C802.16.2a-02/17; “An Addendum to: "A Simplified Method for the Estimation of Rain Attenuation at 10.5 GHz" (G. Jack Garrison, 02/04/15)
- [] IEEE C802.16.2a-02/16; “Coexistence Same Area Simulations at 10.5 GHz (Outbound)” (G. Jack Garrison, 02/04/10)
- [] IEEE C802.16.2a-02/15; “A Simplified Method for the Estimation of Rain Attenuation at 10.5 GHz”(G. Jack Garrison, 02/04/01)
- [] IEEE C802.16.2a-02/14; “Estimates of the Horizon Distance at 3.5 and 10.5 GHz” (G. Jack Garrison, 02/03/28)
- [] IEEE C802.16.2a-02/13; “Outbound Boundary pfd Simulations at 3.5 GHz” (G. Jack Garrison, 02/03/28)
- [] IEEE C802.16.2a-02/12; “CS to CS Boundary pfd Simulations at 3.5 GHz” (G. Jack Garrison, 02/03/28)
- [] IEEE C802.16.2a-02/09; “Coexistence Same Area C/I Simulation Estimates at 3.5 GHz (CS to CS)” (G. Jack Garrison, 02/03/19)
- [] IEEE C802.16.2a-02/08; “Coexistence Same Area Simulations at 3.5 GHz (Inbound)” (G. Jack Garrison, 02/03/16)
- [] IEEE C802.16.2a-02/07; “Coexistence Same Area Simulations at 3.5 GHz (Outbound)” (G. Jack Garrison, 02/03/16)
- [] IEEE C802.16.2a-02/03; “A TS Antenna RPE Sensitivity Analysis for Boundary Coexistence at 10.5 GHz” (G. Jack Garrison, 02/01/02)

2002-05-10

IEEE C802.16.2a-02/27

[] IEEE C802.16.2a-02/02r1 [Rev. 0: 01/12/15]; “Coexistence Co-Channel Boundary pfd Simulations at 3.5 GHz (Inbound)” (G. Jack Garrison, 02/03/01)

[] IEEE C802.16.2a-02/01r1 [Rev. 0: 01/12/02]; “Coexistence Co-Channel Boundary pfd Simulations at 10.5 GHz (Inbound)” (G. Jack Garrison, 02/03/01)

[] IEEE C802.16.2a-01/14; “Path Loss Calculation Plots for 2.5 GHz Systems” (James C. Cornelius, 02/01/07)

[] IEEE C802.16.2a-01/13; “Propagation in the frequency range 2-11 GHz” (G. Jack Garrison, 01/11/15)

[] IEEE C802.16.2a-01/12; “System parameters for 2-11 GHz Coexistence Simulations, Revision 2” (Philip Whitehead, 01/11/15)

[] IEEE C802.16.2a-01/08; “Methods of Predicting Interference - FCC Appendix D” (David Chauncey, 01/09/13)

[] IEEE C802.16.2a-01/05; “System parameters for 2-11 GHz Coexistence Simulations (revision 1)” (Philip Whitehead, 01/09/13)

Editorial instruction; re-label annex G as appropriate and add the following informative references

[1] ETSI TM4 Technical Report DEN TR 4120;

[2] IEEE; Recommended Practice for Coexistence of Fixed Broadband Wireless Systems

[] IEEE S802.16.2a-02/11; “Simulation on Aggregate Interference from Wireless Access Systems including RLANs into Earth Exploration-Satellite Service in the 5250-5350 MHz Band” (Rebecca Chan, 02/03/08)

[] IEEE S802.16.2a-02/10; “Canadian Proposals for the WRC-03 on 5GHz RLAN issues” (Rebecca Chan, 02/03/08)

Other issues (for integration into main text)

[Definitions, Acronyms and Abbreviations (update)]

[Out of block emission limits (review values of Bo and consequent emission limits)]

[Simulation descriptions (add references to complete archived descriptions and results)]

[Introduction (refer to new sections)]

[Participants (new list)]

[Acknowledgements (update)]

[Contents (update)]

[References (update)]

Document History

Version	Date	Notes
1.0	September 2001	First version of working document (output of session #15)
1.1	January 2002	Includes results from contributions prior to session #17
1.2	January 2002	Includes modifications as a result of contributions and conclusions reached at session # 17
1.3	May 2002	Includes modifications as a result of contributions and conclusions reached at session # 18. This version is intended to be the basis for a first formal WG draft, subject to completion and review of all simulations at session #19