

Project	IEEE 802.16 Broadband Wireless Access Working Group < http://ieee802.org/16 >	
Title	Proposal for Radio Conformance Test Specification for P1802.16.3	
Date	2003-05-08	
Submitted		
Source(s)	Lars Lindh Nokia Research Center P.O Box 407 FIN-00045 Nokia Group	Voice: +358 50 483 6671 Fax: +358 7180 36851 mailto:lars.e.lindh@nokia.com
Re:	Re: 1802.16.3-03/01 Call for Contributions on Project 1802.16.3 (03/04/02)	
Abstract	This document contains test procedures for the 802.16 physical layer	
Purpose	To aid TGC in developing the RCT document	
Notice	This document has been prepared to assist IEEE 802.16. It is offered as a basis for discussion and is not binding on the contributing individual(s) or organization(s). The material in this document is subject to change in form and content after further study. The contributor(s) reserve(s) the right to add, amend or withdraw material contained herein.	
Release	The contributor grants a free, irrevocable license to the IEEE to incorporate material contained in this contribution, and any modifications thereof, in the creation of an IEEE Standards publication; to copyright in the IEEE's name any IEEE Standards publication even though it may include portions of this contribution; and at the IEEE's sole discretion to permit others to reproduce in whole or in part the resulting IEEE Standards publication. The contributor also acknowledges and accepts that this contribution may be made public by IEEE 802.16.	
Patent Policy and Procedures	The contributor is familiar with the IEEE 802.16 Patent Policy and Procedures < http://ieee802.org/16/ipr/patents/policy.html >, including the statement "IEEE standards may include the known use of patent(s), including patent applications, provided the IEEE receives assurance from the patent holder or applicant with respect to patents essential for compliance with both mandatory and optional portions of the standard." Early disclosure to the Working Group of patent information that might be relevant to the standard is essential to reduce the possibility for delays in the development process and increase the likelihood that the draft publication will be approved for publication. Please notify the Chair < mailto:chair@wirelessman.org > as early as possible, in written or electronic form, if patented technology (or technology under patent application) might be incorporated into a draft standard being developed within the IEEE 802.16 Working Group. The Chair will disclose this notification via the IEEE 802.16 web site < http://ieee802.org/16/ipr/patents/notices >.	

Contents

1		
2		
3		
4	1. Introduction.....	1
5	2. Scope.....	1
6	3. Purpose.....	1
7	4. References.....	1
8	5. Definitions abbreviations.....	2
9	5.1 Definitions.....	2
10	5.2 Acronyms.....	2
11	6. Overview.....	2
12	6.1 General Requirements.....	3
13	6.2 Test Conditions.....	4
14	7. Environmental requirements.....	4
15	8. Required Tests.....	4
16	9. Test Procedures.....	6
17	9.1 Tests for the Subscriber Station.....	7
18	9.1.1 RS outer code t = 10 / BCC - frame control.....	7
19	9.1.1.1 Test setup.....	7
20	9.1.1.2 Test procedure.....	7
21	9.1.2 RS outer code other bursts.....	8
22	9.1.2.1 Test setup.....	8
23	9.1.2.2 Test procedure.....	8
24	9.1.3 Fixed codeword operation.....	9
25	9.1.3.1 Test setup.....	9
26	9.1.3.2 Test procedure.....	9
27	9.1.4 Shortened last codeword operation.....	10
28	9.1.4.1 Test setup.....	10
29	9.1.4.2 Test procedure.....	10
30	9.1.5 Burst preamble.....	11
31	9.1.5.1 Test setup.....	11
32	9.1.5.2 Test procedure.....	11
33	9.1.6 Modulation.....	12
34	9.1.6.1 Test setup.....	12
35	9.1.6.2 Test procedure.....	12
36	9.1.7 RS outer code - Information Block Length.....	13
37	9.1.7.1 Test setup.....	13
38	9.1.7.2 Test procedure.....	13
39	9.1.8 Randomization with programmable seed.....	14
40	9.1.8.1 Test setup.....	14
41	9.1.8.2 Test procedure.....	14
42	9.1.9 RS outer coder - Initial ranging.....	15
43	9.1.9.1 Test setup.....	15
44	9.1.9.2 Test procedure.....	15
45	9.1.10 RS outer code other bursts.....	16
46	9.1.10.1 Test setup.....	16
47	9.1.10.2 Test procedure.....	16
48	9.1.11 Fixed codeword operation.....	17
49	9.1.11.1 Test setup.....	17
50	9.1.11.2 Test procedure.....	17
51	9.1.12 Shortened last codeword operation.....	18
52	9.1.12.1 Test setup.....	18
53	9.1.12.2 Test procedure.....	18
54	9.1.13 BCC inner code.....	19
55		
56		
57		
58		
59		
60		
61		
62		
63		
64		
65		

1	9.1.13.1	Test setup	19
2	9.1.13.2	Test procedure.....	19
3	9.1.14	Burst preamble	20
4	9.1.14.1	Test setup	20
5	9.1.14.2	Test procedure.....	20
6	9.1.15	Modulation.....	21
7	9.1.15.1	Test setup	21
8	9.1.15.2	Test procedure.....	21
9	9.1.16	RS outer code - Information Block Length	22
10	9.1.16.1	Test setup	22
11	9.1.16.2	Test procedure.....	22
12	9.1.17	Channel allocation	23
13	9.1.17.1	Test setup	23
14	9.1.17.2	Test procedure.....	23
15	9.1.18	Tx Dynamic range	24
16	9.1.18.1	Test setup	24
17	9.1.18.2	Test procedure.....	24
18	9.1.19	Rx Dynamic range	25
19	9.1.19.1	Test setup	25
20	9.1.19.2	Test procedure.....	25
21	9.1.20	Tx Power level at maximum power level setting	26
22	9.1.20.1	Test setup	26
23	9.1.20.2	Test procedure.....	26
24	9.1.21	Tx Power level adjustment step accuracy	27
25	9.1.21.1	Test setup	27
26	9.1.21.2	Test procedure.....	27
27	9.1.22	Symbol timing accuracy	28
28	9.1.22.1	Test setup	28
29	9.1.22.2	Test procedure.....	28
30	9.1.23	Tx Burst timing	29
31	9.1.23.1	Test setup	29
32	9.1.23.2	Test procedure.....	29
33	9.1.24	Carrier frequency	30
34	9.1.24.1	Test setup	30
35	9.1.24.2	Test procedure.....	30
36	9.1.25	Spectral mask.....	31
37	9.1.25.1	Test setup	31
38	9.1.25.2	Test procedure.....	31
39	9.1.26	Ramp up / down time.....	32
40	9.1.26.1	Test setup	32
41	9.1.26.2	Test procedure.....	32
42	9.1.27	Output noise power spectral density when Tx is not transmitting.....	33
43	9.1.27.1	Test setup	33
44	9.1.27.2	Test procedure.....	33
45	9.1.28	Modulation accuracy.....	34
46	9.1.28.1	Test setup	34
47	9.1.28.2	Test procedure.....	34
48	9.1.29	BER performance threshold.....	35
49	9.1.29.1	Test setup	35
50	9.1.29.2	Test procedure.....	35
51	9.1.30	Transition time from Tx to Rx and from Rx to Tx	36
52	9.1.30.1	Test setup	36
53	9.1.30.2	Test procedure.....	36
54	9.1.31	1st adjacent channel interference	37
55			
56			
57			
58			
59			
60			
61			
62			
63			
64			
65			

1	9.1.31.1	Test setup	37
2	9.1.31.2	Test procedure.....	37
3	9.1.32	2nd adjacent channel interference.....	39
4	9.1.32.1	Test setup	39
5	9.1.32.2	Test procedure.....	39
6	9.1.33	Tx Power level absolute accuracy	41
7	9.1.33.1	Test setup	41
8	9.1.33.2	Test procedure.....	41
9	9.2	Tests for the Base Station	42
10	9.2.1	RS outer code t = 10 / BCC - frame control	42
11	9.2.1.1	Test setup	42
12	9.2.1.2	Test procedure.....	42
13	9.2.2	RS outer code other bursts	43
14	9.2.2.1	Test setup	43
15	9.2.2.2	Test procedure.....	43
16	9.2.3	Fixed codeword operation	44
17	9.2.3.1	Test setup	44
18	9.2.3.2	Test procedure.....	44
19	9.2.4	Shortened last codeword operation.....	45
20	9.2.4.1	Test setup	45
21	9.2.4.2	Test procedure.....	45
22	9.2.5	Burst preamble	46
23	9.2.5.1	Test setup	46
24	9.2.5.2	Test procedure.....	46
25	9.2.6	Modulation.....	47
26	9.2.6.1	Test setup	47
27	9.2.6.2	Test procedure.....	47
28	9.2.7	RS outer code - Information Block Length	48
29	9.2.7.1	Test setup	48
30	9.2.7.2	Test procedure.....	48
31	9.2.8	Randomization with programmable seed	49
32	9.2.8.1	Test setup	49
33	9.2.8.2	Test procedure.....	49
34	9.2.9	RS outer code - Initial ranging.....	50
35	9.2.9.1	Test setup	50
36	9.2.9.2	Test procedure.....	50
37	9.2.10	RS outer code other bursts	51
38	9.2.10.1	Test setup	51
39	9.2.10.2	Test procedure.....	51
40	9.2.11	Fixed codeword operation	52
41	9.2.11.1	Test setup	52
42	9.2.11.2	Test procedure.....	52
43	9.2.12	Shortened last codeword operation.....	53
44	9.2.12.1	Test setup	53
45	9.2.12.2	Test procedure.....	53
46	9.2.13	BCC inner code.....	54
47	9.2.13.1	Test setup	54
48	9.2.13.2	Test procedure.....	54
49	9.2.14	Burst preamble	55
50	9.2.14.1	Test setup	55
51	9.2.14.2	Test procedure.....	55
52	9.2.15	Modulation.....	56
53	9.2.15.1	Test setup	56
54	9.2.15.2	Test procedure.....	56
55			
56			
57			
58			
59			
60			
61			
62			
63			
64			
65			

1	9.2.16	RS outer code - Information Block Length	57
2	9.2.16.1	Test setup	57
3	9.2.16.2	Test procedure.....	57
4	9.2.17	Channel allocation	58
5	9.2.17.1	Test setup	58
6	9.2.17.2	Test procedure.....	58
7	9.2.18	Symbol timing accuracy	59
8	9.2.18.1	Test setup	59
9	9.2.18.2	Test procedure.....	59
10	9.2.19	Carrier frequency	60
11	9.2.19.1	Test setup	60
12	9.2.19.2	Test procedure.....	60
13	9.2.20	Spectral mask.....	61
14	9.2.20.1	Test setup	61
15	9.2.20.2	Test procedure.....	61
16	9.2.21	Spurious	62
17	9.2.21.1	Test setup	62
18	9.2.21.2	Test procedure.....	62
19	9.2.22	Tx RMS Power level.....	63
20	9.2.22.1	Test setup	63
21	9.2.22.2	Test procedure.....	63
22	9.2.23	Ramp up / down time.....	64
23	9.2.23.1	Test setup	64
24	9.2.23.2	Test procedure.....	64
25	9.2.24	Modulation accuracy.....	65
26	9.2.24.1	Test setup	65
27	9.2.24.2	Test procedure.....	65
28	9.2.25	Rx Dynamic range	66
29	9.2.25.1	Test setup	66
30	9.2.25.2	Test procedure.....	66
31	9.2.26	BER performance threshold.....	67
32	9.2.26.1	Test setup	67
33	9.2.26.2	Test procedure.....	67
34	9.2.27	1st adjacent channel interference	68
35	9.2.27.1	Test setup	68
36	9.2.27.2	Test procedure.....	68
37	9.2.28	2nd adjacent channel interference.....	70
38	9.2.28.1	Test setup	70
39	9.2.28.2	Test procedure.....	70
40	10. Annex A.....		71
41	10.1 Requirements for the test laboratories		71
42	11. Test equipment.....		71
43	12. General test platform		72
44	13. Carrier frequencies.....		72
45			
46			
47			
48			
49			
50			
51			
52			
53			
54			
55			
56			
57			
58			
59			
60			
61			
62			
63			
64			
65			

Proposal for Radio Conformance Test specification for P1802.16.3

Lars Lindh

Nokia

1. Introduction

To evaluate conformance of a particular implementation of a radio interface, it is necessary to have a common radio testing document with common radio test procedures as outlined in the Test Suite Structure and Test Purposes (TSS&TP) document. The Radio Conformance Test (RCT) specification document serves this purpose.

2. Scope

This document is a specification for the radio conformance test of the 802.16 PHY layer.

The scope of the document is as follows:

It specifies the test procedures and the test conditions in order to ensure the interoperability between equipment developed by different manufacturers. This is achieved by testing the baseband and RF signal processing functionalities in the transmitter and the receiver. The specification covers basic RF aspects, including the radio frequency channel plans and those other parameters necessary for radio regulatory coexistence purposes.

The tests correspond to the requirements in the Test Purposes in the IEEE 802.16 10–66 GHz conformance testing. Sub-part 2: "Test Suite Structure and Test Purposes (TSS & TP) Specification". The requirements are given in conjunction with the tests.

Requirements for the test laboratories are given in Annex A

3. Purpose

In order to ensure interoperability between the equipment built by different manufacturers from the PHY-perspective and compliance with IEEE Std 802.16-200: "Local and Metropolitan Area Networks – Part 16: Standard Air Interface for Fixed Wireless Access Systems", standardized conformance test procedures for the PHY specifications are specified. However, for supporting these test procedure some basic functionalities from the MAC layer are required.

In order to perform these tests some dedicated test equipment and testing capabilities are required by the test laboratories.

4. References

The following documents contain provisions, which, through reference in this text, constitute provisions of the present document.

References are either specific (identified by date of publication, edition number, version number, etc.) or non-specific. For a specific reference, subsequent revisions do not apply.

For non-specific references, the latest versions apply.

- [1] IEEE Std 802.16-200: "Local and Metropolitan Area Networks – Part 16: Standard Air Interface for Fixed Wireless Access Systems"
- [2] ISO/IEC 9646-1: "Information technology – Open Systems Interconnection – Conformance testing methodology and framework – Part 1: General concepts"
- [3] ISO/IEC 9646-7: "Information technology - Open Systems Interconnection – Conformance testing methodology and framework - Part 6: Protocol profile test specification"
- [4] ISO/IEC 9646-7: "Information technology – Open Systems Interconnection – Conformance testing methodology and framework – Part 7: Implementation Conformance Statements"
- [5] IEEE 802.16c-2002: "Amendment to IEEE Standard for Local and Metropolitan Area Networks – Part 16: Air Interface for Broadband Fixed Wireless Access Systems – Detailed System profiles for 10-66 GHz"
- [6] IEEE P1802.16.1/D1-2002: "Protocol Implementation Conformance Statements for 10-66 GHz Wireless-MAN-SC Air Interface"
- [7] IEEE 802.16 10–66 GHz conformance testing. Sub-part 2: "Test Suite Structure and Test Purposes (TSS & TP) Specification"

5. Definitions abbreviations

5.1 Definitions

For the purposes of this document, the terms defined in [1], as amended by [5], [6], and [7] apply.

5.2 Acronyms

For the purposes of this document, the acronyms defined in [1], as amended by [5], [6], and [7] apply.

6. Overview

The IEEE 802.16 Part 16: "Air Interface for Fixed Broadband Wireless Access Systems" specifies the 802.16 transmission scheme in order to guarantee interoperability between equipment developed by different manufacturers. This is achieved by describing all signal processing structures and all protocol issues.

The 802.16 Radio Conformance Testing specification (RCT) is intended to specify the conformance testing procedures and requirements (in both directions for both the BS and SS) of all parameters specified in the physical layer. The test requirements are defined in IEEE 802.16 10–66 GHz conformance testing. Sub-part 2: "Test Suite Structure and Test Purposes (TSS & TP) Specification" and are also described in conjunction with the test procedures.

In addition to the main requirements of the 802.16 RCT, Test Laboratory equipment requirements are described in Annex A.

The general block diagram of the 802.16 downlink and uplink system is illustrated in Figure 1.

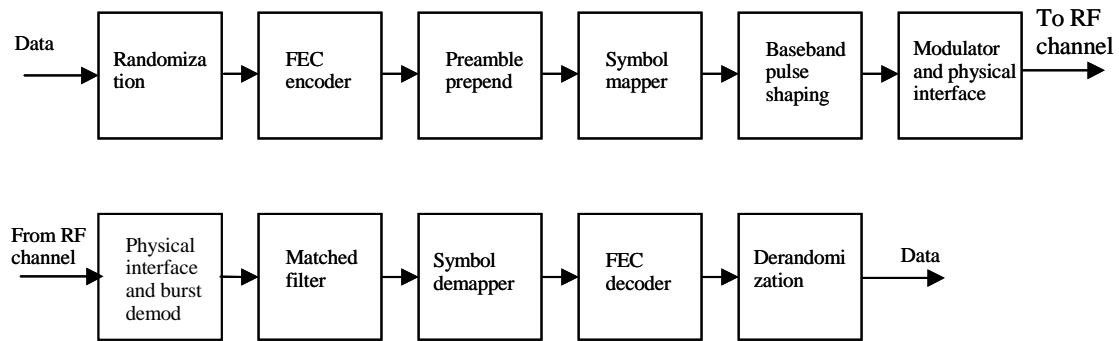

Figure 1—PHY layer conceptual block diagram

6.1 General Requirements

The general block-diagram with naming of test interfaces is given in Figure 2. The block diagram describes only conceptually the main system components and interfaces, and does not dictate any implementation. The manufacturer shall during the testing occasion make the signals in the listed interfaces available for measurements.

The following abbreviations have been used:

- A: Antenna interface
- M: MAC interface
- SC: Symbol Clock interface

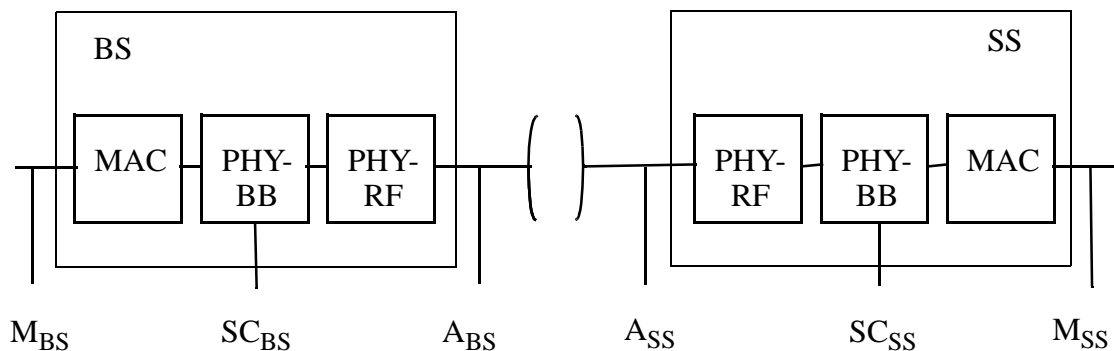

Figure 2—General block diagram

6.2 Test Conditions

7. Environmental requirements

8. Required Tests

The required tests are described in the IEEE 802.16 10–66 GHz conformance testing. Sub-part 2: "Test Suite Structure and Test Purposes (TSS & TP) Specification" [7] and listed in table 1. Test Procedures

Table 1—Required tests

	Mandatory	Optional
Parameters for the Subscriber Station		
Downlink		
RS outer code $t = 10$ / BCC - frame control	M	
RS outer code other bursts	M	
Fixed codeword operation	M	
Shortened last codeword operation	M	
Burst preamble	M	
Modulation	M	
RS outer code - information block length	M	
Uplink		
Randomization with programmable seed	M	
RS outer coder - initial ranging	M	
RS outer code other bursts	M	
Fixed codeword operation	M	
Shortened last codeword operation	M	
BCC inner code	M	
Burst preamble	M	
Modulation	M	
RS outer code - information block length	M	
Minimum performance		
Channel allocation	M	
Transmitter dynamic range	M	
Receiver dynamic range	M	
Transmitter RMS power level at maximum power level setting	M	

Table 1—Required tests (continued)

Transmitter power level adjustment step accuracy	M	
Symbol timing accuracy	M	
Transmitter burst timing	M	
Carrier frequency	M	
Spectral mask	M	
Ramp up / ramp down	M	
Output noise power spectral density	M	
Modulation accuracy	M	
BER performance threshold	M	
Transition time from Tx to Rx and from Rx to Tx	M	
1st adjacent channel interference	M	
2nd adjacent channel interference	M	
Parameters for the Base Station		
Downlink		
RS outer code $t = 10$ / BCC - frame control	M	
RS outer code other bursts	M	
Fixed codeword operation	M	
Shortened last codeword operation	M	
Burst preamble	M	
Modulation	M	
RS outer code - information block length	M	
Uplink		
Randomization with programmable seed	M	
RS outer coder - initial ranging	M	
RS outer code other bursts	M	
Fixed codeword operation	M	
Shortened last codeword operation	M	
BCC inner code	M	
Burst preamble	M	
Modulation	M	
RS outer code - information block length	M	
Minimum performance		
Channel allocation	M	
Symbol timing accuracy	M	

1
2
3
4
5
6
7
8
9
10
11
12
13
14
15
16
17
18
19
20
21
22
23
24
25
26
27
28
29
30
31
32
33
34
35
36
37
38
39
40
41
42
43
44
45
46
47
48
49
50
51
52
53
54
55
56
57
58
59
60
61
62
63
64
65

Table 1—Required tests (continued)

Carrier frequency	M	
Spectral mask	M	
Spurious	M	
Transmitter RMS power level	M	
Ramp up / ramp down	M	
Modulation accuracy	M	
Receiver dynamic range	M	
BER performance threshold	M	
1st adjacent channel interference	M	
2nd adjacent channel interference	M	

9. Test Procedures

Some test procedures assume that the counterpart for the IUT, denoted “Test BS”, “Test SS” or “Tester”, has some additional features not mandated by the 802.16 standard. These features are solely there to aid the test procedures. Typical tester functions are: capability to eject gating signals for the measurement instruments, special software for requesting a special behaviour of the IUT. The Tester also has significantly better and known output signal quality than the IUT.

9.1 Tests for the Subscriber Station

9.1.1 RS outer code $t = 10$ / BCC - frame control

9.1.1.1 Test setup

Figure 3 shows the test setup for testing the RS outer code $t = 10$ / BCC - frame control.

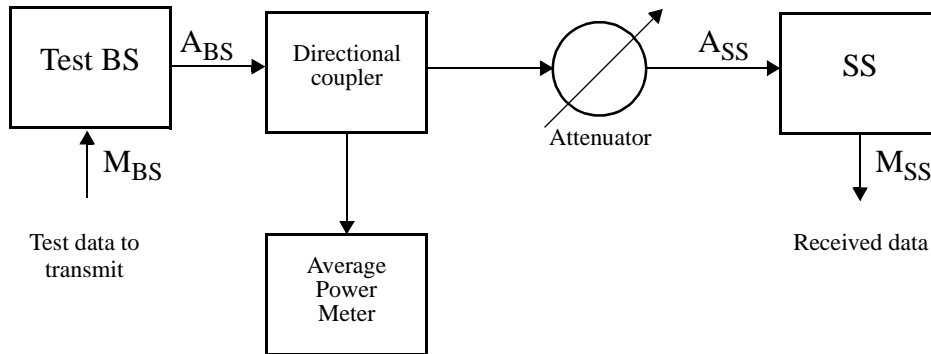

Figure 3—Test setup for RS outer code $t = 10$ / BCC - frame control

Instruments needed: Directional coupler
 Attenuator
 Average power meter

9.1.1.2 Test procedure

The losses for the coupler and the connecting waveguides are measured and the attenuator is calibrated. When measuring the power the losses and the effect of the coupler shall be taken into account

A connection is setup between the Test BS and the SS. The Test BS is setup to send data consisting of frames filled with QPSK modulated data and coded with Block Convolutional Code + Reed Solomon $t = 4$. The number of information bytes in a RS block shall be 128. The data received at the SS is compared with the transmitted data.

The attenuator is adjusted until the received power is $-98 + 10\log(B)$ dBm, where B is the symbol rate in MBaud.

The bit error rate (BER) is measured at the SS from the payload of the accepted packets and shall be less than $1.12 \cdot 10^{-7}$. This test procedure, using the FEC, is in conformance with the BER requirement of uncoded QPSK in the base specification [1]. The fact that the packets are received correctly proves that the decoding of the frame control portion, BCC + Reed-Solomon $t=10$, works correctly. The measured BER is another proof of that the BCC decoding works satisfactorily.

9.1.2 RS outer code other bursts

9.1.2.1 Test setup

Figure 4 shows the test setup for testing the RS outer code other bursts.

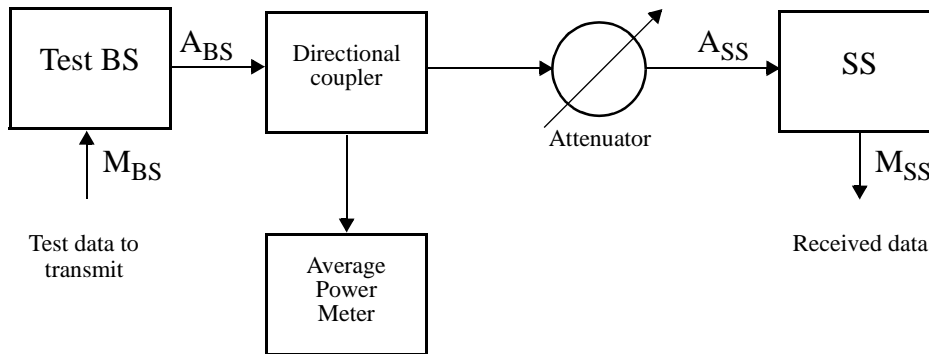

Figure 4—Test setup for RS outer code other bursts

Instruments needed:

- Directional coupler
- Attenuator
- Average power meter

9.1.2.2 Test procedure

The losses for the coupler and the connecting waveguides are measured and the attenuator is calibrated. When measuring the power the losses and the effect of the coupler shall be taken into account.

A connection is setup between the Test BS and the SS. The Test BS transmits the bursts with QPSK modulation, no BCC coding, RS coding with $t = 0, 4, 8$ and 12 , and information bytes = 128 .

The downlink frame is filled with bursts of test data. The received power is adjusted until the S/N is 10 dB above the actual threshold. The data received at the SS is checked for correctness.

The Test BS inserts alternatively $0, 4, 8$ or 12 erroneous bytes in the codeword corresponding to $t = 0, 4, 8$ and 12 . The SS shall receive the data correctly.

The Test BS inserts alternatively $1, 5, 9$ or 13 erroneous bytes in the codeword corresponding to $t = 0, 4, 8$ and 12 . The SS shall not be able to receive the data correctly.

9.1.3 Fixed codeword operation

9.1.3.1 Test setup

Figure 5 shows the test setup for testing the RS fixed codeword operation.

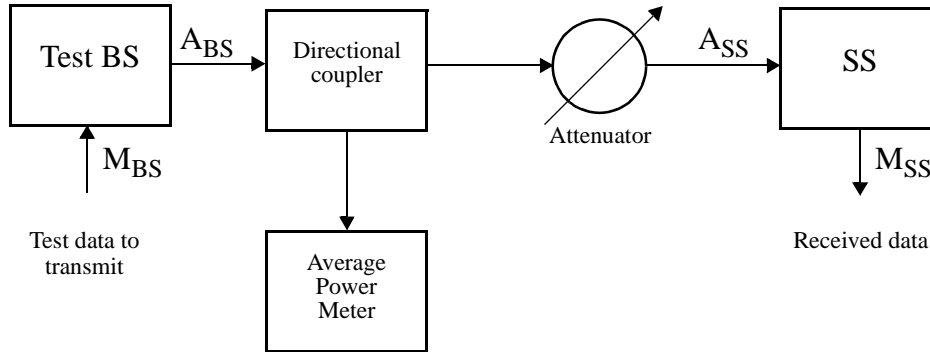

Figure 5—Test setup for Fixed codeword operation

Instruments needed:

- Directional coupler
- Attenuator
- Average power meter

9.1.3.2 Test procedure

The losses for the coupler and the connecting waveguides are measured and the attenuator is calibrated. When measuring the power the losses and the effect of the coupler shall be taken into account.

A connection is setup between the Test BS and the SS. The Test BS transmits the bursts with Reed-Solomon using Fixed codeword option, QPSK modulation, no BCC coding, RS coding with $t = 8$ and information bytes = 128.

The downlink frame is filled with bursts of test data. The number of bytes in the downlink frame must not be a multiple of 128. The received power is adjusted until the S/N is 10 dB above the actual threshold.

The SS receives the data correctly.

9.1.4 Shortened last codeword operation

9.1.4.1 Test setup

Figure 6 shows the test setup for testing the RS shortened codeword operation.

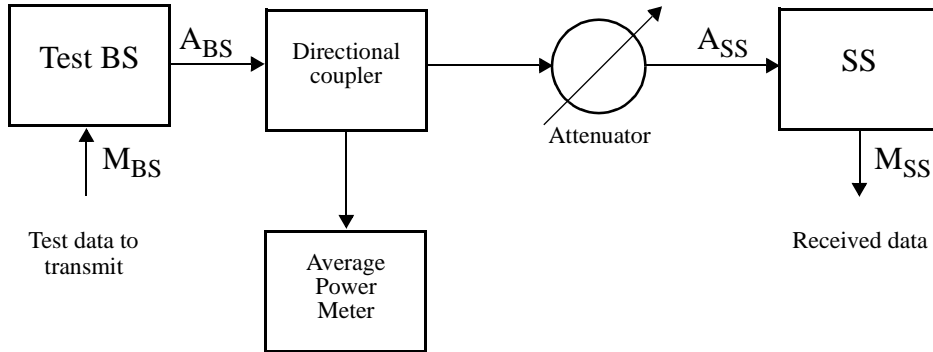

Figure 6—Test setup for Shortened codeword operation

Instruments needed: Directional coupler
 Attenuator
 Average power meter

9.1.4.2 Test procedure

The losses for the coupler and the connecting waveguides are measured and the attenuator is calibrated. When measuring the power the losses and the effect of the coupler shall be taken into account.

A connection is setup between the Test BS and the SS. The Test BS transmits the bursts with Reed-Solomon using Shortened codeword option, QPSK modulation, no BCC coding, RS coding with $t = 8$ and information bytes = 128.

The downlink frame is filled with bursts of test data. The number of bytes in the downlink frame must be not be a multiple of 128. The received power is adjusted until the S/N is 10 dB above the actual threshold.

The SS receives the data correctly.

9.1.5 Burst preamble

9.1.5.1 Test setup

Figure 7 shows the test setup for testing the burst preamble.

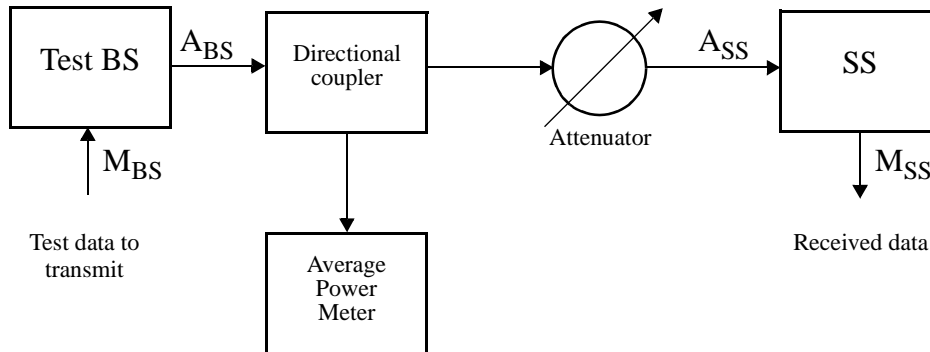

Figure 7—Test setup for burst preamble

Instruments needed:

- Directional coupler
- Attenuator
- Average power meter

9.1.5.2 Test procedure

The losses for the coupler and the connecting waveguides are measured and the attenuator is calibrated. When measuring the power the losses and the effect of the coupler shall be taken into account.

A connection is setup between the Test BS and the SS. The Test BS is setup to transmit data in the TDMA portion of the frame.

The downlink frame is filled with bursts of test data. The received power is adjusted until the S/N is 10 dB above the actual threshold.

The SS receives the data correctly.

The fact that the SS receives the data correctly proves that the SS is able to synchronize to burst preambles, which are in the beginning of each TDMA burst.

1
2
3
4
5
6
7
8
9
10
11
12
13
14
15
16
17
18
19
20
21
22
23
24
25
26
27
28
29
30
31
32
33
34
35
36
37
38
39
40
41
42
43
44
45
46
47
48
49
50
51
52
53
54
55
56
57
58
59
60
61
62
63
64
65

9.1.6 Modulation

9.1.6.1 Test setup

Figure 8 shows the test setup for testing the modulation.

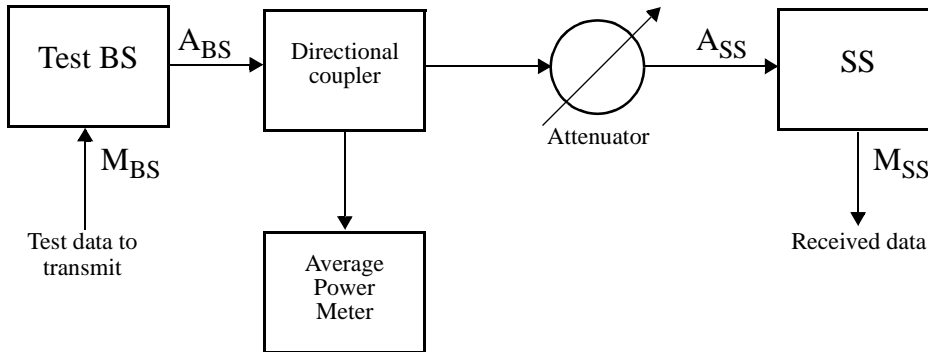

Figure 8—Test setup for modulation

Instruments needed: Directional coupler
 Attenuator
 Average power meter

9.1.6.2 Test procedure

The losses for the coupler and the connecting waveguides are measured and the attenuator is calibrated. When measuring the power the losses and the effect of the coupler shall be taken into account.

A connection is setup between the Test BS and the SS. The Test BS is setup to transmit data in the TDM and TDMA portions of the frame with all modulation schemes supported by the SS.

The downlink frame is filled with bursts of test data. The received power is adjusted until the S/N is 10 dB above the actual thresholds.

The SS receives the data correctly.

9.1.7 RS outer code - Information Block Length

9.1.7.1 Test setup

Figure 9 shows the test setup for testing the RS outer code - Information Block Length.

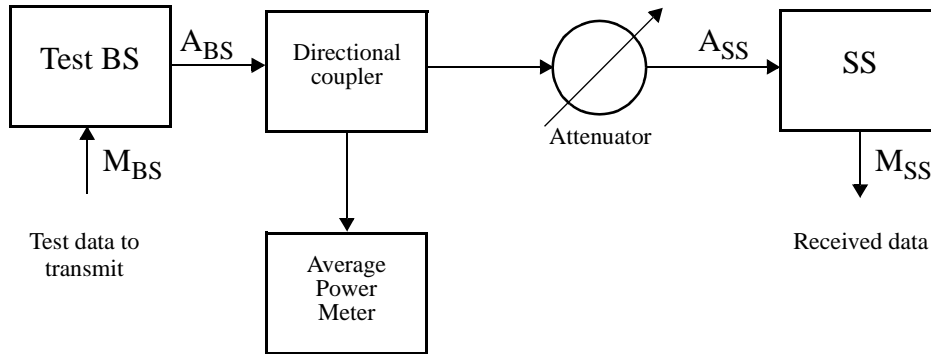

Figure 9—Test setup for RS outer code - Information Block Length

Instruments needed:

- Directional coupler
- Attenuator
- Average power meter

9.1.7.2 Test procedure

The losses for the coupler and the connecting waveguides are measured and the attenuator is calibrated. When measuring the power the losses and the effect of the coupler shall be taken into account.

A connection is setup between the Test BS and the SS. QPSK modulation, no BCC coding, RS coding with information block length = 6, 128, 239 and $t = 8$ are used.

The downlink frame is filled with bursts of test data. The received power is adjusted until the S/N is 10 dB above the actual threshold.

The SS shall receive the data correctly.

9.1.8 Randomization with programmable seed

9.1.8.1 Test setup

Figure 10 shows the test setup for randomization with programmable seed.

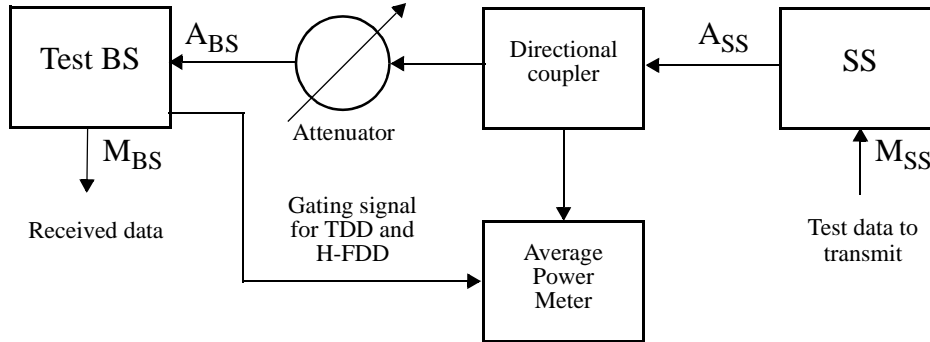

Figure 10—Test setup for randomization with programmable seed

Instruments needed: Directional coupler
 Attenuator
 Average power meter

9.1.8.2 Test procedure

The losses for the coupler and the connecting waveguides are measured and the attenuator is calibrated. When measuring the power the losses and the effect of the coupler shall be taken into account.

A connection is setup between the Test BS and the SS. The Test BS commands the SS to use burst profiles with different seed values for the randomization.

Data is transmitted in the uplink.

The Test BS shall receive the data correctly.

9.1.9 RS outer coder - Initial ranging

9.1.9.1 Test setup

Figure 11 shows the test setup for testing the RS outer code - Initial ranging.

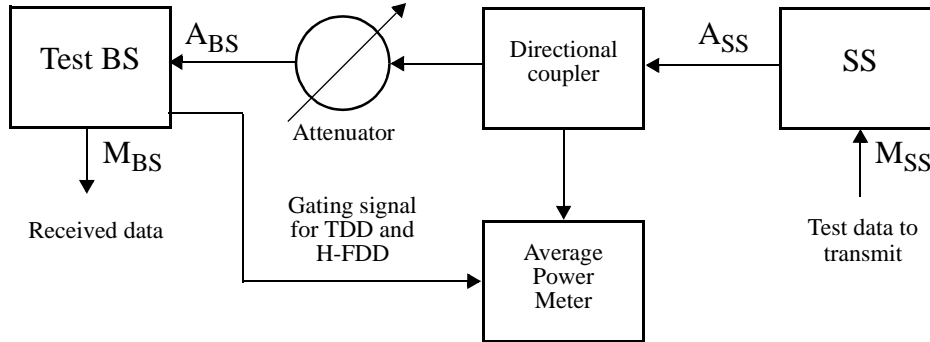

Figure 11—Test setup for RS outer code - Initial ranging

Instruments needed: Directional coupler
 Attenuator
 Average power meter

9.1.9.2 Test procedure

The losses for the coupler and the connecting waveguides are measured and the attenuator is calibrated. When measuring the power the losses and the effect of the coupler shall be taken into account.

A connection is setup between the Test BS and the SS.

The Test BS commands the SS to use burst profiles with RS parameter $t = 10$ for initial ranging.

The SS sends a RNG-REQ message in the initial ranging opportunity. The Test BS receives the data correctly.

9.1.10 RS outer code other bursts

9.1.10.1 Test setup

Figure 12 shows the test setup for testing the RS outer code other bursts.

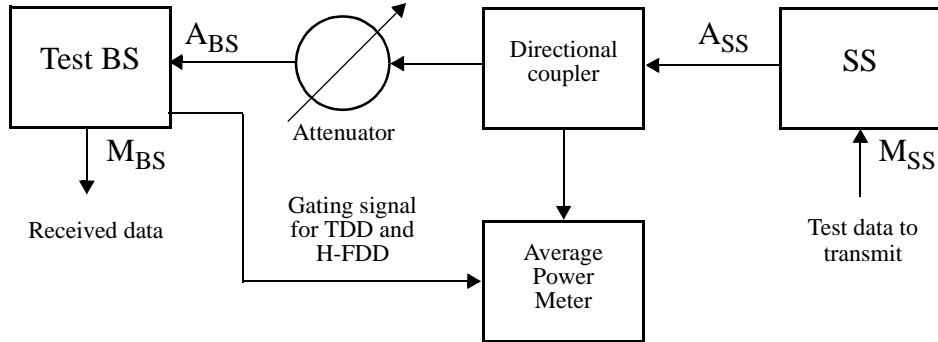

Figure 12—Test setup for RS outer code other bursts

Instruments needed: Directional coupler
 Attenuator
 Average power meter

9.1.10.2 Test procedure

The losses for the coupler and the connecting waveguides are measured and the attenuator is calibrated. When measuring the power the losses and the effect of the coupler shall be taken into account.

A connection is setup between the Test BS and the SS. The Test BS commands the SS to use burst profiles with the RS parameter $t = 0, 4, 8$ or 12 , and information bytes 128 are used.

Data is transmitted in the uplink

The Test BS receives the data correctly.

9.1.11 Fixed codeword operation

9.1.11.1 Test setup

Figure 13 shows the test setup for testing the RS fixed codeword operation.

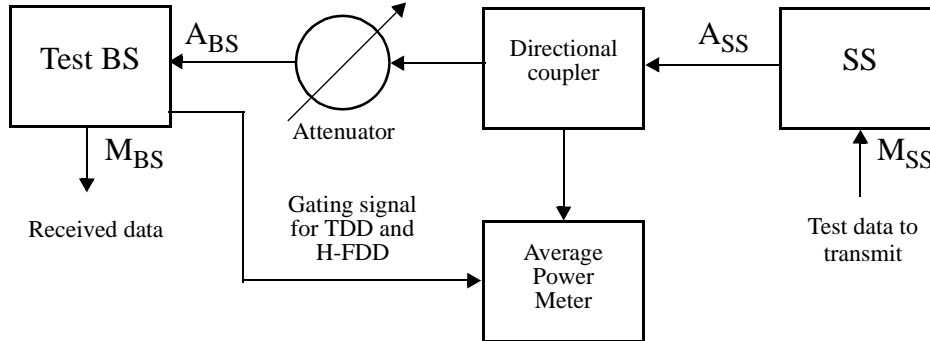

Figure 13—Test setup for Fixed codeword operation

Instruments needed:

- Directional coupler
- Attenuator
- Average power meter

9.1.11.2 Test procedure

The losses for the coupler and the connecting waveguides are measured and the attenuator is calibrated. When measuring the power the losses and the effect of the coupler shall be taken into account.

A connection is setup between the Test BS and the SS. The Test BS commands the SS to use burst profiles with Reed-Solomon Fixed codeword option, QPSK modulation, no BCC coding, RS coding with $t = 8$ and information bytes = 128 in all uplink bursts. The number of bytes in the downlink frame must be not be a multiple of 128.

Data is transmitted in the uplink.

The Test BS receives the data correctly.

9.1.12 Shortened last codeword operation

9.1.12.1 Test setup

Figure 14 shows the test setup for testing the RS shortened codeword operation.

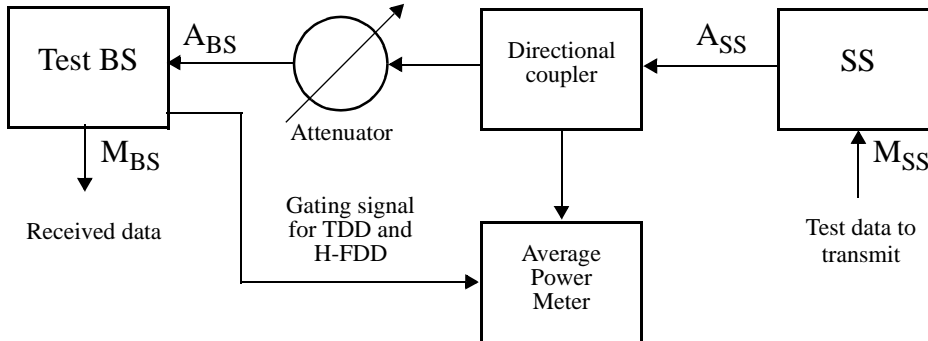

Figure 14—Test setup for Shortened codeword operation

Instruments needed: Directional coupler
 Attenuator
 Average power meter

9.1.12.2 Test procedure

The losses for the coupler and the connecting waveguides are measured and the attenuator is calibrated. When measuring the power the losses and the effect of the coupler shall be taken into account.

A connection is setup between the Test BS and the SS. The Test BS commands the SS to use burst profiles with Reed-Solomon Shortened codeword, QPSK modulation, no BCC coding, RS coding with $t = 8$ and information bytes = 128 in all uplink bursts. The number of bytes in the downlink frame must be not be a multiple of 128.

Data is transmitted in the uplink.

The Test BS receives the data correctly.

9.1.13 BCC inner code

9.1.13.1 Test setup

Figure 15 shows the test setup for testing the BCC innercode operation.

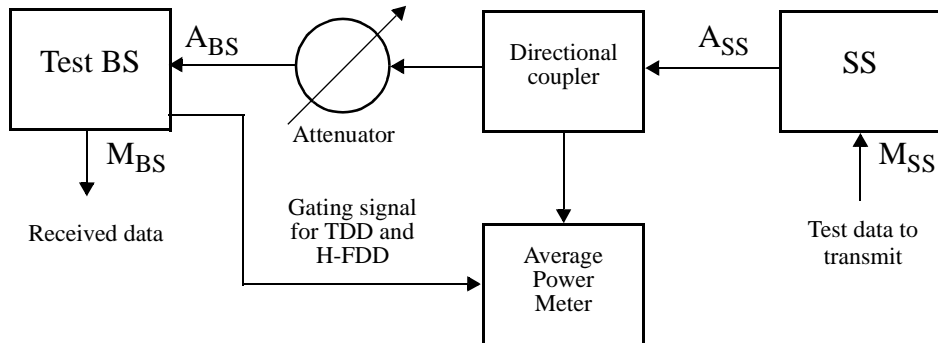

Figure 15—Test setup for BCC inner code operation

Instruments needed: Directional coupler
 Attenuator
 Average power meter

9.1.13.2 Test procedure

The losses for the coupler and the connecting waveguides are measured and the attenuator is calibrated. When measuring the power the losses and the effect of the coupler shall be taken into account.

A connection is setup between the Test BS and the SS. The Test BS commands the SS to use burst profiles with BCC inner code in all uplink bursts.

Data is transmitted in the uplink.

The Test BS receives the data correctly.

9.1.14 Burst preamble

9.1.14.1 Test setup

Figure 16 shows the test setup for testing the burst preamble.

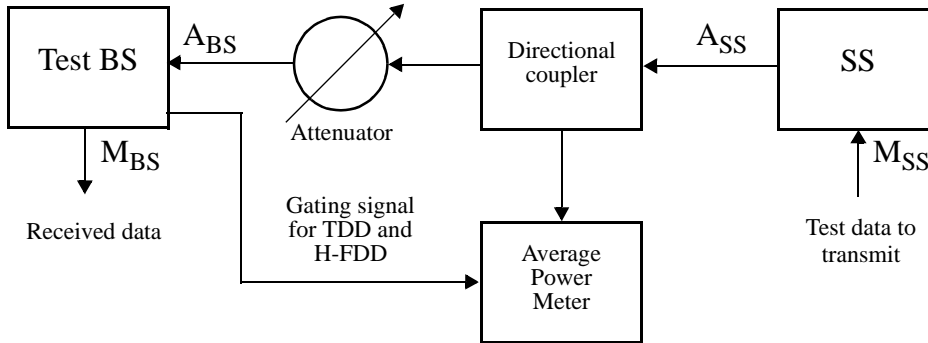

Figure 16—Test setup for burst preamble

Instruments needed:

- Directional coupler
- Attenuator
- Average power meter

9.1.14.2 Test procedure

The losses for the coupler and the connecting waveguides are measured and the attenuator is calibrated. When measuring the power the losses and the effect of the coupler shall be taken into account.

A connection is setup between the Test BS and the SS. The Test BS commands the SS to use burst profiles with different preamble lengths in the uplink bursts.

Data is transmitted in the uplink.

The Test BS receives the data correctly.

9.1.15 Modulation

9.1.15.1 Test setup

Figure 17 shows the test setup for testing the modulation schemes.

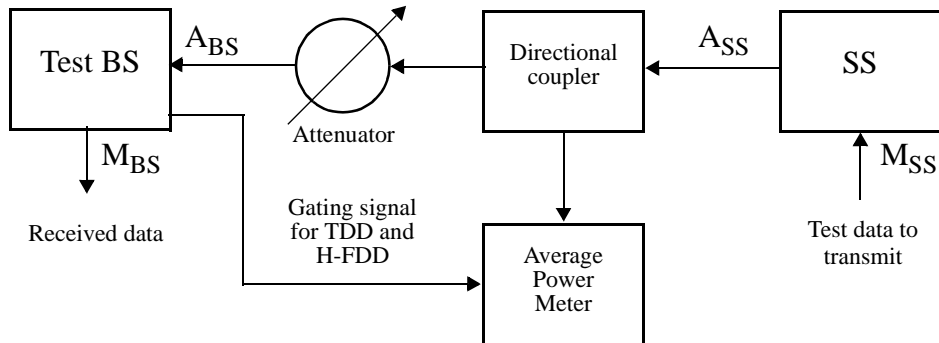

Figure 17—Test setup for the modulation schemes

Instruments needed:

- Directional coupler
- Attenuator
- Average power meter

9.1.15.2 Test procedure

The losses for the coupler and the connecting waveguides are measured and the attenuator is calibrated. When measuring the power the losses and the effect of the coupler shall be taken into account.

A connection is setup between the Test BS and the SS. The Test BS commands the SS to use burst profiles with the different modulation schemes supported by the SS in the uplink bursts.

Data is transmitted in the uplink.

The Test BS receives the data correctly.

9.1.16 RS outer code - Information Block Length

9.1.16.1 Test setup

Figure 18 shows the test setup for testing the RS outer code - Information Block Length.

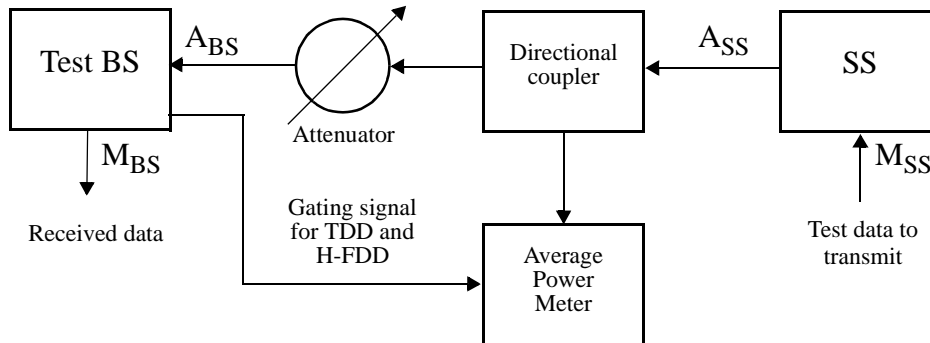

Figure 18—Test setup for RS outer code - Information Block Length

Instruments needed:

- Directional coupler
- Attenuator
- Average power meter

9.1.16.2 Test procedure

The losses for the coupler and the connecting waveguides are measured and the attenuator is calibrated. When measuring the power the losses and the effect of the coupler shall be taken into account.

A connection is setup between the Test BS and the SS. The Test BS commands the SS to use burst profiles with the the RS parameter Information block length = 6, 128 and 239. RS parameter $t = 8$.

Data is transmitted in the uplink.

The Test BS receives the data correctly.

9.1.17 Channel allocation

9.1.17.1 Test setup

Figure 19 shows the test setup for testing the channel allocation.

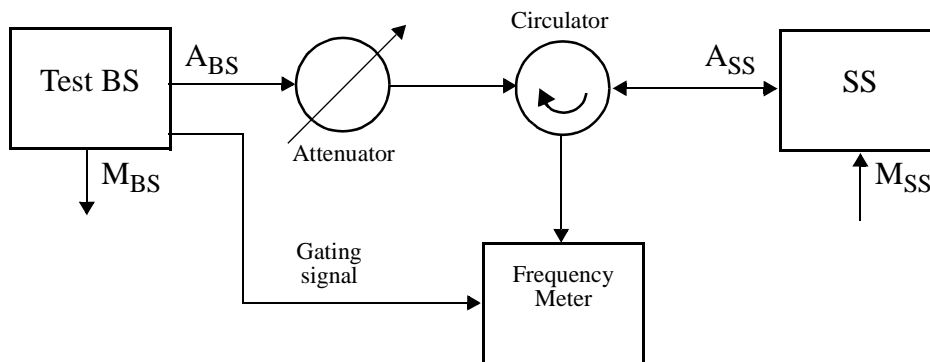

Figure 19—Test setup for Channel allocation

Instruments needed:

- Circulator
- Attenuator
- Frequency meter

9.1.17.2 Test procedure

The Test BS and the SS are set in the CW test mode. The attenuator is adjusted for an optimal reception level

The Test BS generates frequencies which are multiples of 250 KHz in frequency range declared by the SS manufacturer

The SS is able to lock to the frequencies generated by the Test BS. For TDD the frequencies for the Test BS and SS shall be equal and for FDD they shall be separated by the duplex distance declared by the manufacturer.

9.1.18 Tx Dynamic range

9.1.18.1 Test setup

Figure 20 shows the test setup for testing the Tx Dynamic Range

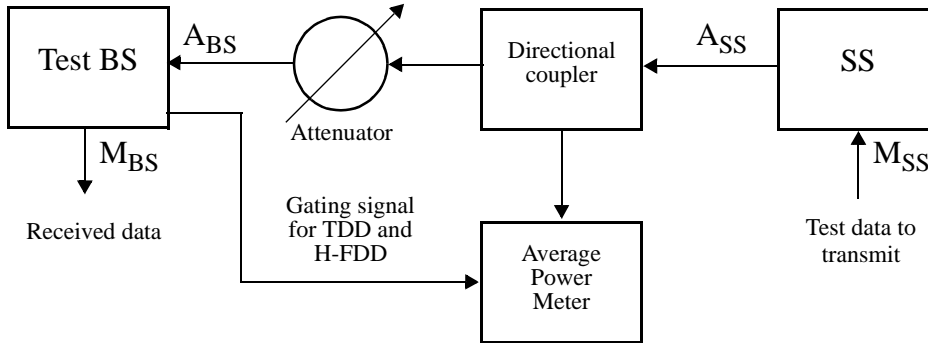

Figure 20—Test setup for Tx Dynamic Range

Instruments needed:

- Directional coupler
- Attenuator
- Average power meter

9.1.18.2 Test procedure

The losses for the coupler and the connecting waveguides are measured and the attenuator is calibrated. When measuring the power the losses and the effect of the coupler shall be taken into account.

A connection is setup between the Test BS and the SS. The Test BS commands the SS to use the most robust burst profile. Data is transmitted in the uplink.

The attenuator is slowly adjusted to its lowest value and as a consequence the SS shall decrease its transmit power until the minimum operable value is achieved. The transmitted power is measured and recorded. The attenuator is then slowly increased until the SS reaches its maximum operable value. The transmitted power is measured and recorded.

The difference between the two power values is the Tx dynamic range and shall be ≥ 40 dB.

9.1.19 Rx Dynamic range

9.1.19.1 Test setup

Figure 21 shows the test setup for testing the Rx Dynamic Range

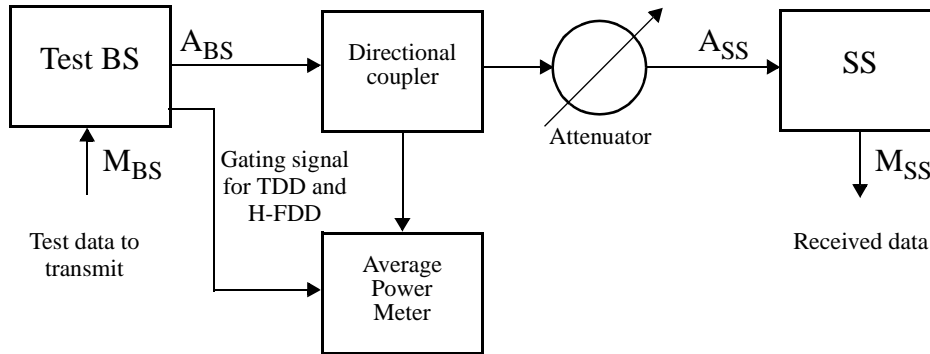

Figure 21—Test setup for Rx Dynamic Range

Instruments needed:

- Directional coupler
- Attenuator
- Average power meter

9.1.19.2 Test procedure

The losses for the coupler and the connecting waveguides are measured and the attenuator is calibrated. When measuring the power the losses and the effect of the coupler shall be taken into account.

A connection is setup between the Test BS and the SS. The Test BS commands the SS to use the most robust burst profile. Data is transmitted in the downlink.

The attenuator is slowly adjusted to its lowest operable value. The power of the received signal is measured and recorded. The attenuator is then slowly increased until the the maximum operable value is reached. The power is measured and recorded.

The difference between the two power values is the Rx dynamic range and shall be ≥ 40 dB.

9.1.20 Tx Power level at maximum power level setting

9.1.20.1 Test setup

Figure 20 shows the test setup for testing the Tx Power level at maximum power level setting

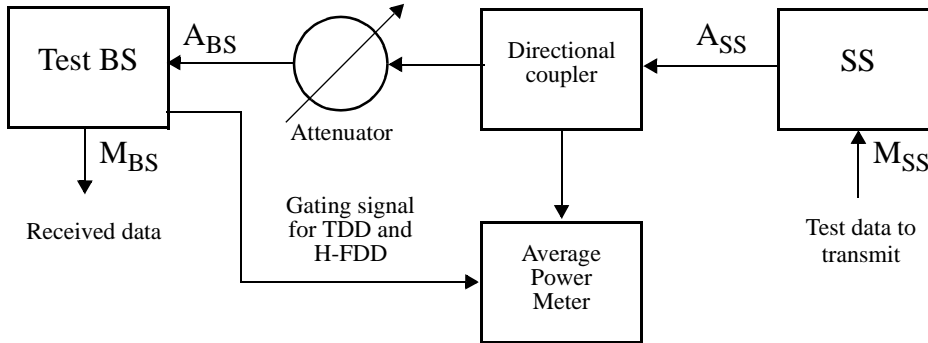

Figure 22—Test setup for Tx Power at maximum power level setting

Instruments needed:

- Directional coupler
- Attenuator
- Average power meter

9.1.20.2 Test procedure

The losses for the coupler and the connecting waveguides are measured and the attenuator is calibrated. When measuring the power the losses and the effect of the coupler shall be taken into account.

A connection is setup between the Test BS and the SS. The Test BS commands the SS to use the most robust burst profile. Data is transmitted in the uplink.

The attenuator is slowly adjusted towards its highest value until the SS increases its transmit power to its maximum. The Test BS shall receive the data correctly. The power is measured

The power shall be ≥ 15 dBm.

9.1.21 Tx Power level adjustment step accuracy

9.1.21.1 Test setup

Figure 23 shows the test setup for testing the Tx Power level adjustment step accuracy.

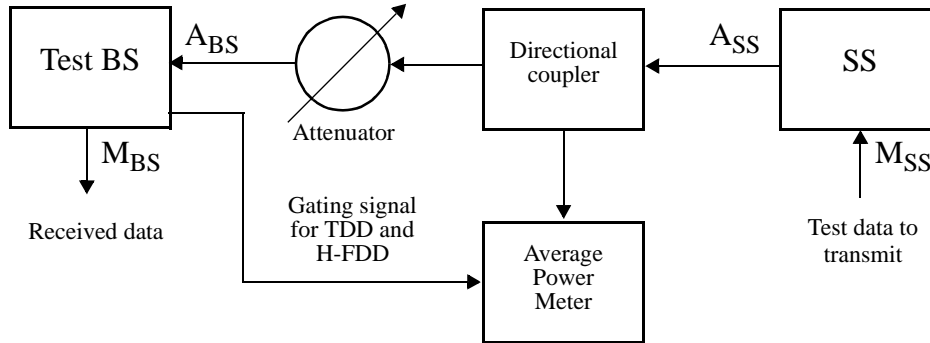

Figure 23—Test setup for Tx Power level step adjustment step accuracy

Instruments needed:

- Directional coupler
- Attenuator
- Average power meter

9.1.21.2 Test procedure

The losses for the coupler and the connecting waveguides are measured and the attenuator is calibrated. When measuring the power the losses and the effect of the coupler shall be taken into account.

A connection is setup between the Test BS and the SS. The Test BS commands the SS to use the most robust burst profile at the bottom, medium and top values of the transmit power range. Data is transmitted in the uplink. The transmit power is measured

The Test BS commands the SS to adjust its transmit power level with the step sizes +/- [0.5 - 2.0] dB, +/- [2 - 5] dB and > +/- 5 dB.

The measured change in power shall be monotonically positive (negative), +/- 2 dB of the requested change, +/- 5 dB of the requested change.

9.1.22 Symbol timing accuracy

9.1.22.1 Test setup

Figure 24 shows the test setup for testing the symbol timing accuracy.

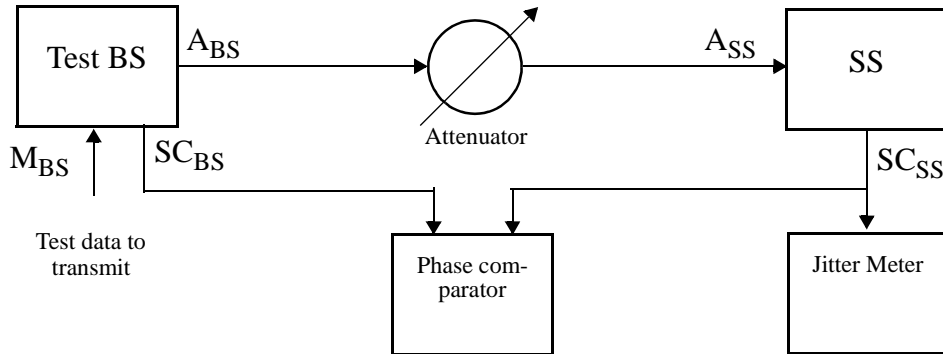

Figure 24—Test setup for symbol timing accuracy

Instruments needed:

- Directional coupler
- Attenuator
- Jitter meter
- Phase comparator

9.1.22.2 Test procedure

The losses for the coupler and the connecting waveguides are measured and the attenuator is calibrated. When measuring the power the losses and the effect of the coupler shall be taken into account.

A connection is setup between the Test BS and the SS. The downlink frame is filled with bursts of QPSK modulated data. The received power is adjusted until the S/N is 10 dB above the actual threshold.

The jitter of the SS symbol clock is measured. Peak-to-peak jitter during a 2 sec measurement period must be less than 2 %.

The symbol clock of the Test BS and SS are connected to a phase comparator. The SS shall be locked to the Test BS symbol clock.

9.1.23 Tx Burst timing

9.1.23.1 Test setup

Figure 25 shows the test setup for testing the Tx Burst timing.

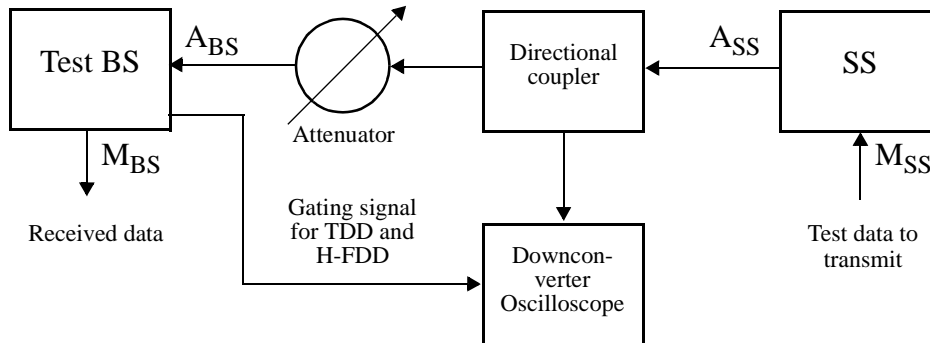

Figure 25—Test setup for Tx Burst timing

Instruments needed:

- Directional coupler
- Attenuator
- Downconveter
- Oscilloscope

9.1.23.2 Test procedure

The losses for the coupler and the connecting waveguides are measured and the attenuator is calibrated. When measuring the power the losses and the effect of the coupler shall be taken into account.

A connection is setup between the Test BS and the SS. Data is transmitted in the uplink with QPSK modulation.

The Test BS defines the burst at different positions with 0.25 symbol time resolution by using unsolicited RNG-RSP messages.

The actual position of the burst is compared with the gating signal provided by the Test BS. The difference shall be less than 0.125 symbol time.

9.1.24 Carrier frequency

9.1.24.1 Test setup

Figure 26 shows the test setup for testing the carrier frequency.

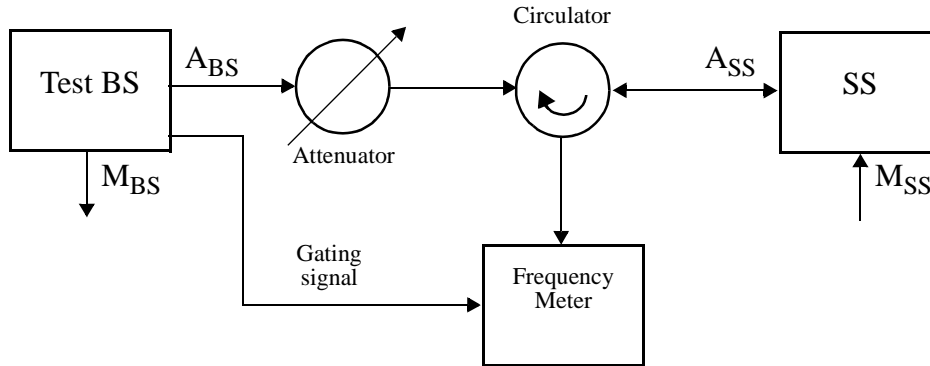

Figure 26—Test setup for Carrier frequency

Instruments needed: Circulator
 Attenuator
 Frequency meter

9.1.24.2 Test procedure

The Test BS and the SS are set in the CW test mode. The attenuator is adjusted for an optimal reception level

The Test BS generates frequencies which are multiples of 250 KHz in frequency range declared by the SS manufacturer

The SS is able to lock to the frequencies generated by the Test BS. For TDD the frequencies for the Test BS and SS shall be equal and for FDD they shall be separated by the duplex distance declared by the manufacturer.

9.1.25 Spectral mask

9.1.25.1 Test setup

Figure 27 shows the test setup for testing the spectral mask.

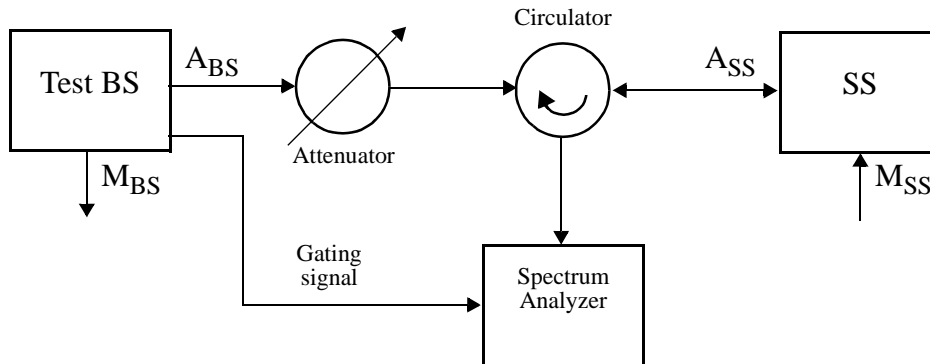

Figure 27—Test setup for Spectral mask

Instruments needed: Circulator
 Attenuator
 Spectrum Analyzer

9.1.25.2 Test procedure

The losses for the coupler and the connecting waveguides are measured and the attenuator is calibrated. When measuring the power the losses and the effect of the coupler shall be taken into account.

A connection is setup between the Test BS and the SS. The Test BS commands the SS to use the most robust burst profile. Data is transmitted in the uplink.

The spectrum is measured with a spectrum analyzer. The spectrum shall not exceed the mask given by the local regulator.

The settings of the spectrum analyzer shall be according to table 2

Table 2—Spectrum analyzer settings

Paramter	SS
Center frequency	Actual
Span	140 MHz
Scan time	Auto
Resolution bandwidth	300 KHz
Video bandwidth	100 KHz

9.1.26 Ramp up / down time

9.1.26.1 Test setup

Figure 28 shows the test setup for testing the Ramp up / down time.

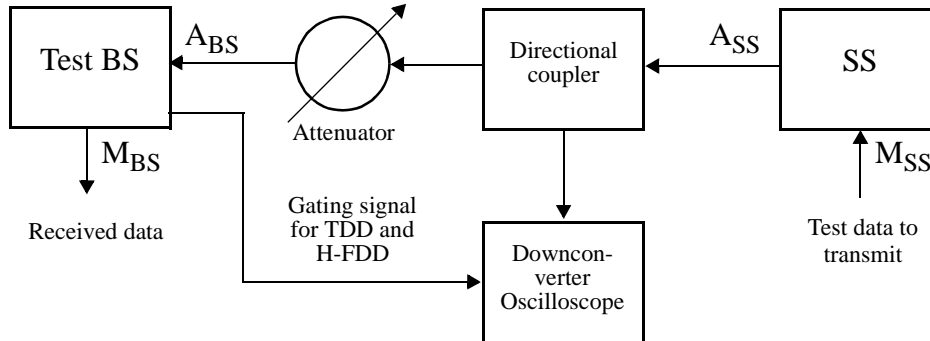

Figure 28—Test setup for Ramp up / down time

Instruments needed:

- Directional coupler
- Attenuator
- Downconerter
- Oscilloscope

9.1.26.2 Test procedure

The losses for the coupler and the connecting waveguides are measured and the attenuator is calibrated. When measuring the power the losses and the effect of the coupler shall be taken into account.

A connection is setup between the Test BS and the SS. Data is transmitted in the uplink with QPSK modulation.

The ramp up/ ramp down times are measured and shall be ≤ 24 symbols.

9.1.27 Output noise power spectral density when Tx is not transmitting

9.1.27.1 Test setup

Figure 29 shows the test setup for testing the Output noise power spectral density.

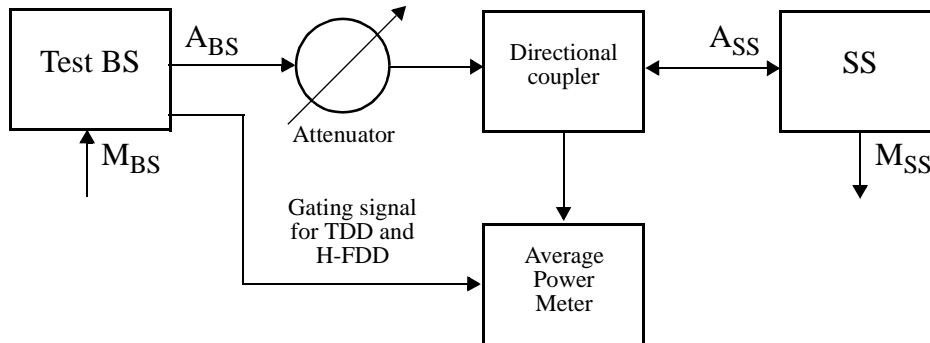

Figure 29—Test setup for Output noise power spectral density

Instruments needed: Directional coupler
 Attenuator
 Average power meter

9.1.27.2 Test procedure

The losses for the coupler and the connecting waveguides are measured and the attenuator is calibrated. When measuring the power the losses and the effect of the coupler shall be taken into account.

The SS is operable, listening to the downlink. No connections are setup.

The output noise power emitted from the SS when not transmitting shall be ≤ -80 dBm/Mhz

1
2
3
4
5
6
7
8
9
10
11
12
13
14
15
16
17
18
19
20
21
22
23
24
25
26
27
28
29
30
31
32
33
34
35
36
37
38
39
40
41
42
43
44
45
46
47
48
49
50
51
52
53
54
55
56
57
58
59
60
61
62
63
64
65

9.1.28 Modulation accuracy

9.1.28.1 Test setup

Figure 29 shows the test setup for testing the modulation accuracy.

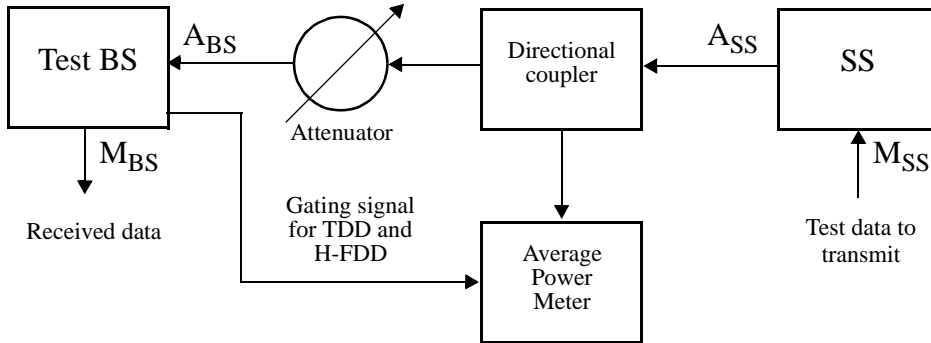

Figure 30—Test setup for Modulation accuracy

Instruments needed: Directional coupler
 Attenuator
 Average power meter

9.1.28.2 Test procedure

The losses for the coupler and the connecting waveguides are measured and the attenuator is calibrated. When measuring the power the losses and the effect of the coupler shall be taken into account.

The system is setup for a BER test for the Test BS. The sensitivity value P for the Test BS for BER=10⁻³ is measured using a high quality transmitter as the signal source.

The sensitivity value M for the Test BS for BER=10⁻³ is measured using the SS as the signal source. The difference M - P shall be less than or equal to the values in column 2 in table 3. The corresponding EVM figures are shown in columns 3 and 4.

Table 3—EVM requirements

	Tx implementation margin	EVM no equalizer	EVM equalizer
QPSK	0.5 dB	12 %	10 %
16-QAM	1.0 dB	6 %	3 %
64-QAM	1.5 dB		1.5 %

9.1.29 BER performance threshold

9.1.29.1 Test setup

Figure 31 shows the test setup for testing the BER performance threshold.

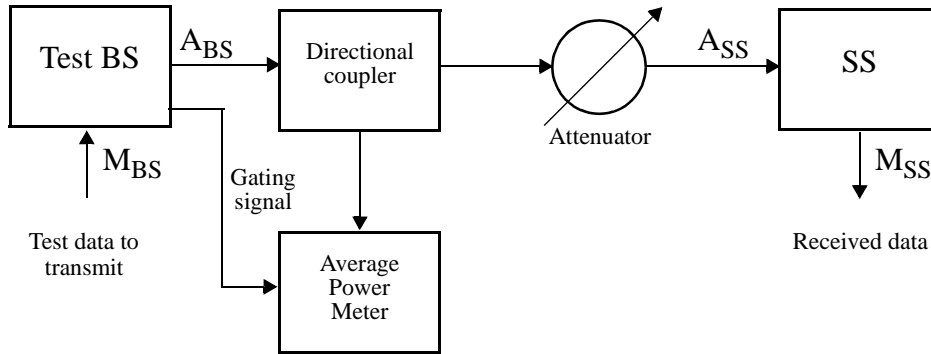

Figure 31—Test setup for BER performance threshold

Instruments needed: Directional coupler
 Attenuator
 Average power meter

9.1.29.2 Test procedure

The losses for the coupler and the connecting waveguides are measured and the attenuator is calibrated. When measuring the power the losses and the effect of the coupler shall be taken into account.

A connection is setup between the Test BS and the SS. The Test BS transmits the bursts with all supported modulation schemes and no FEC. CRC is disabled

The BER is computed from the payload of the data packets accepted by the SS. The attenuator is adjusted until $BER = 10^{-3}$ and then 10^{-6} . The input power is measured and shall be according to table 4. B is the symbol rate in MBaud.

Table 4—BER performance threshold sensitivity values

	BER 10^{-3}	BER 10^{-6}
QPSK	$-94 + 10\log(B)$ dBm	$-90 + 10\log(B)$ dBm
16-QAM	$-87 + 10\log(B)$ dBm	$-83 + 10\log(B)$ dBm
64-QAM	$-79 + 10\log(B)$ dBm	$-74 + 10\log(B)$ dBm

9.1.30 Transition time from Tx to Rx and from Rx to Tx

9.1.30.1 Test setup

Figure 32 shows the test setup for testing the Transition time from Tx to Rx and from Rx to Tx.

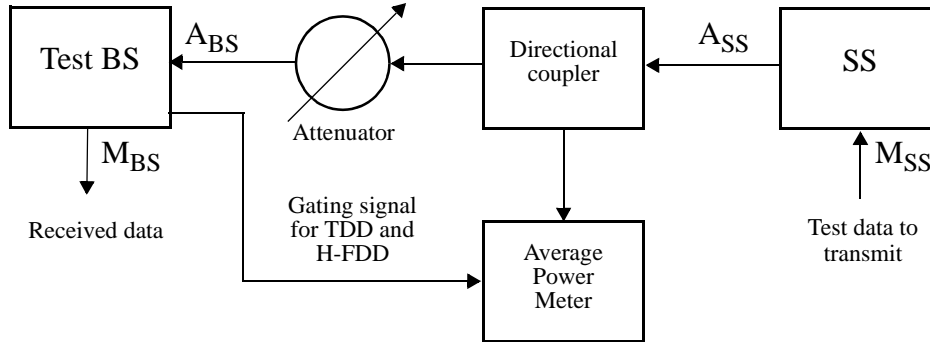

Figure 32—Test setup for Transition time from Tx to Rx and from Rx to Tx

Instruments needed:

- Directional coupler
- Attenuator
- Average power meter

9.1.30.2 Test procedure

The losses for the coupler and the connecting waveguides are measured and the attenuator is calibrated. When measuring the power the losses and the effect of the coupler shall be taken into account.

A connection is setup between the Test BS and the SS. The attenuator is adjusted for an optimal signal quality. The Test BS provides downlink and uplink maps with a transition time between the end of an uplink burst and the start of a downlink burst of 2 us for TDD and 20 us for H-FDD and with transition times between the end of a downlink burst and start of an uplink burst of 2 us for TDD and 20 us for H-FDD. Uplink and downlink data is generated.

The SS successfully transmits uplink data and receives downlink data.

9.1.31 1st adjacent channel interference

9.1.31.1 Test setup

Figure 33 shows the test setup for testing the 1st adjacent channel interference.

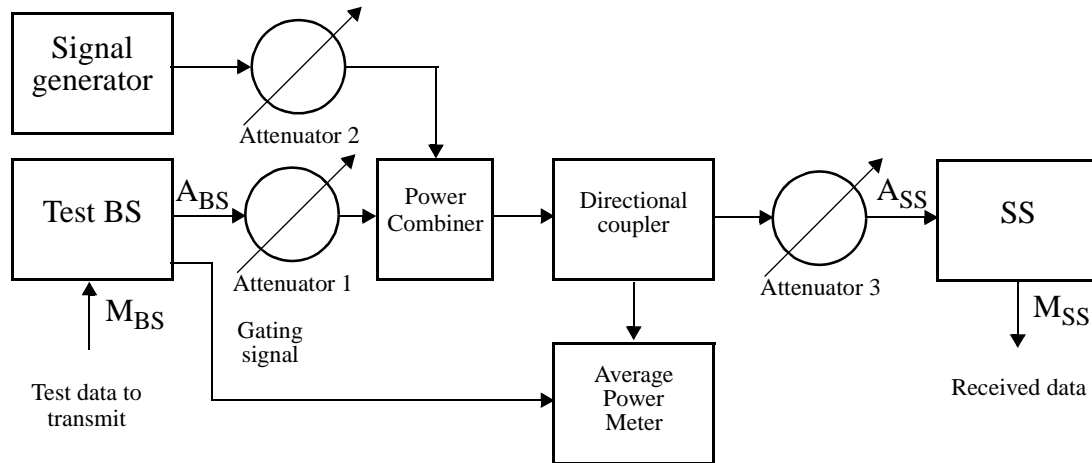

Figure 33—Test setup for 1st adjacent channel interference

Instruments needed:

- Directional coupler
- Attenuators
- Average power meter
- Power combiner

9.1.31.2 Test procedure

The losses for the coupler and the connecting waveguides are measured and the attenuators are calibrated. When measuring the power the losses and the effect of the coupler shall be taken into account. Attenuators 1 and 2 are used to adjust the ratio between the useful and interfering signals. Attenuator 3 is used for adjusting the absolute signal level at the receiver and can be held at a constant value of 10 dB. The signal generator transmits a similar signal as the useful signal on the first adjacent channel.

A connection is setup between the Test BS and the SS. Attenuator 2 is set to its maximum value and the signal generator is switched off. Downlink QPSK data is generated and attenuator 1 is adjusted for $BER = 10^{-3}$ (10^{-6}). The signal power is increased by 3 (1) dB and the power is measured.

The signal generator is switched on and attenuator 2 is decreased until $BER = 10^{-3}$ (10^{-6}) is achieved. The Test BS is turned off and the power of the interfering signal is measured.

The procedure is repeated for the other modulation schemes, 1 dB degradation and $BER = 10^{-6}$. The C/I values shall be according to tables 5 and 6.

Table 5—1st adjacent channel interference BER 10^{-3}

	1 dB degradation	3 dB degradation
QPSK	-5 dB	-9 dB
16-QAM	+2 dB	-2 dB
64-QAM	+9 dB	+5 dB

Table 6—1st adjacent channel interference BER= 10^{-6}

	1 dB degradation	3 dB degradation
QPSK	-1 dB	-5 dB
16-QAM	+6 dB	+2 dB
64-QAM	+13 dB	+9 dB

9.1.32 2nd adjacent channel interference

9.1.32.1 Test setup

Figure 34 shows the test setup for testing the 2nd adjacent channel interference.

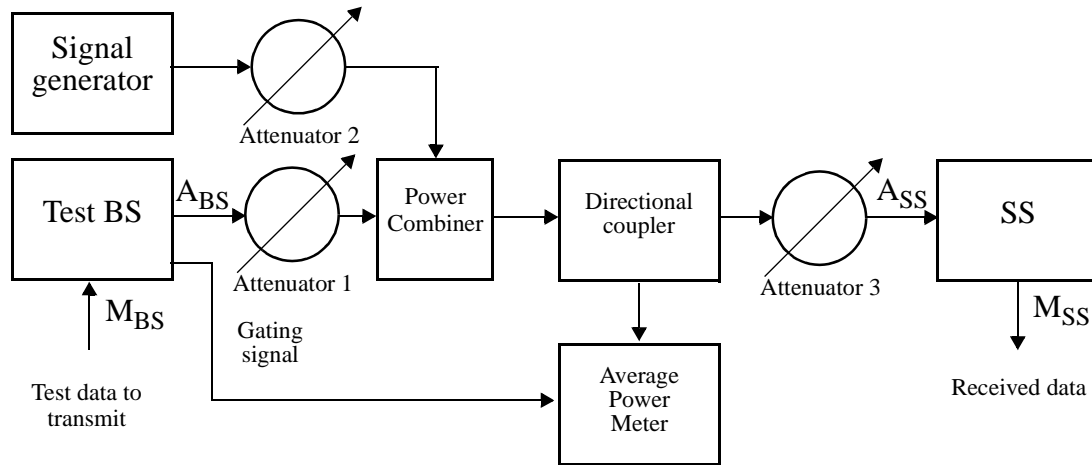

Figure 34—Test setup for 2nd adjacent channel interference

Instruments needed:

- Directional coupler
- Attenuators
- Average power meter
- Power combiner

9.1.32.2 Test procedure

The losses for the coupler and the connecting waveguides are measured and the attenuators are calibrated. When measuring the power the losses and the effect of the coupler shall be taken into account. Attenuators 1 and 2 are used to adjust the ratio between the useful and interfering signals. Attenuator 3 is used for adjusting the absolute signal level at the receiver and can be held at a constant value of 10 dB. The signal generator transmits a similar signal as the useful signal on the second adjacent channel.

A connection is setup between the Test BS and the SS. Attenuator 2 is set to its maximum value and the signal generator is switched off. Downlink QPSK data is generated and attenuator 1 is adjusted for BER = 10^{-3} (10^{-6}). The signal power is increased by 3 (1) dB and the power is measured.

The signal generator is switched on and attenuator 2 is decreased until BER = 10^{-3} (10^{-6}) is achieved. The Test BS is turned off and the power of the interfering signal is measured.

The procedure is repeated for the other modulation schemes, 1 dB degradation and BER = 10^{-6} . The C/I values shall be according to tables 7 and 8.

1
2
3
4
5
6
7
8
9
10
11
12
13
14
15
16
17
18
19
20
21
22
23
24
25
26
27
28
29
30
31
32
33
34
35
36
37
38
39
40
41
42
43
44
45
46
47
48
49
50
51
52
53
54
55
56
57
58
59
60
61
62
63
64
65

Table 7—2nd adjacent channel interference BER 10^{-3}

	1 dB degradation	3 dB degradation
QPSK	-30 dB	-34 dB
16-QAM	-22 dB	-27 dB
64-QAM	-16 dB	-20 dB

Table 8—2nd adjacent channel interference BER= 10^{-6}

	1 dB degradation	3 dB degradation
QPSK	-26 dB	-30 dB
16-QAM	-20 dB	-23 dB
64-QAM	-12 dB	-16 dB

9.1.33 Tx Power level absolute accuracy

9.1.33.1 Test setup

Figure 35 shows the test setup for testing the Tx Power level absolute accuracy.

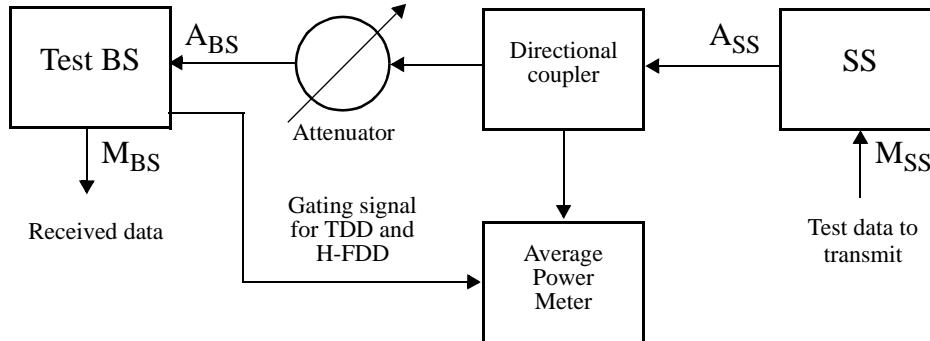

Figure 35—Test setup for Tx Power level absolute accuracy

Instruments needed:

- Directional coupler
- Attenuator
- Average power meter

9.1.33.2 Test procedure

The losses for the coupler and the connecting waveguides are measured and the attenuator is calibrated. When measuring the power the losses and the effect of the coupler shall be taken into account.

A connection is setup between the Test BS and the SS. The Test BS commands the SS to use the most robust burst profile at the bottom, medium and top values of the transmit power range. Data is transmitted in the uplink. The transmit power is measured

The Test BS commands the SS to adjust its transmit power level to an absolute level in the current power range. The Test BS shall receive the data correctly.

The accuracy of the power level shall be +/- 6 dB.

9.2 Tests for the Base Station

9.2.1 RS outer code $t = 10$ / BCC - frame control

9.2.1.1 Test setup

Figure 36 shows the test setup for testing the RS outer code $t = 10$ / BCC - frame control.

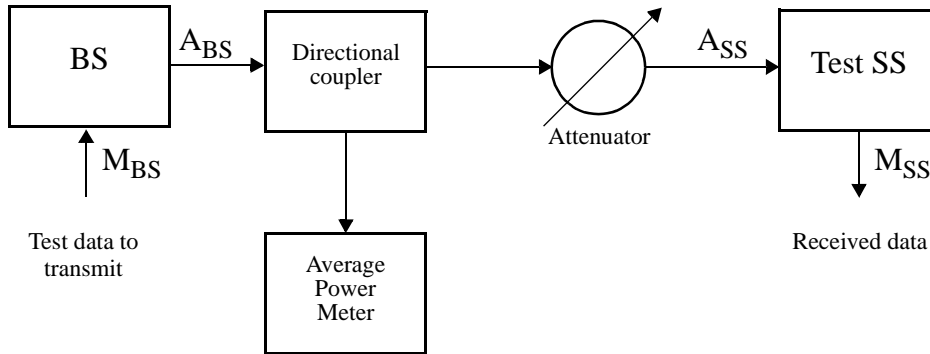

Figure 36—Test setup for RS outer code $t = 10$ / BCC - frame control

Instruments needed: Directional coupler
 Attenuator
 Average power meter

9.2.1.2 Test procedure

The losses for the coupler and the connecting waveguides are measured and the attenuator is calibrated. When measuring the power the losses and the effect of the coupler shall be taken into account

A connection is setup between the BS and the Test SS. The attenuator is increased until the Test SS requests the BS to use the most robust burst profile. Data is sent in the downlink.

The Test SS receives the data correctly.

9.2.2 RS outer code other bursts

9.2.2.1 Test setup

Figure 37 shows the test setup for testing the RS outer code other bursts.

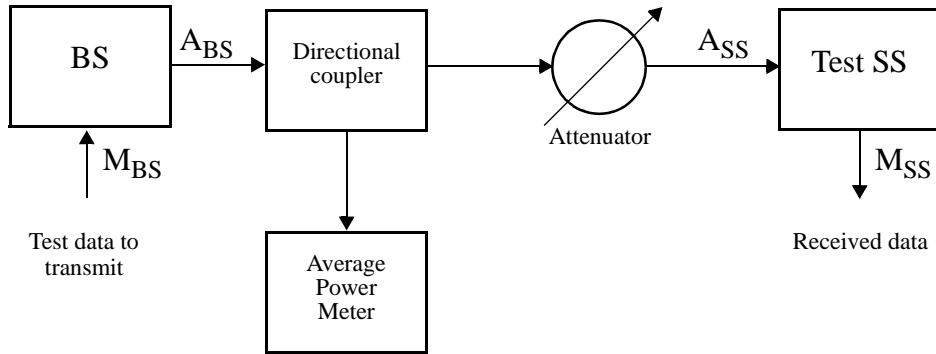

Figure 37—Test setup for RS outer code other bursts

Instruments needed:

- Directional coupler
- Attenuator
- Average power meter

9.2.2.2 Test procedure

The losses for the coupler and the connecting waveguides are measured and the attenuator is calibrated. When measuring the power the losses and the effect of the coupler shall be taken into account.

A connection is setup between the BS and the Test SS. The Test SS requests the BS to use bursts profiles with RS parameter $t = 0, 4, 8$ and 12 . Data is transmitted in the downlink.

The SS shall receive the data correctly.

9.2.3 Fixed codeword operation

9.2.3.1 Test setup

Figure 38 shows the test setup for testing the RS fixed codeword operation.

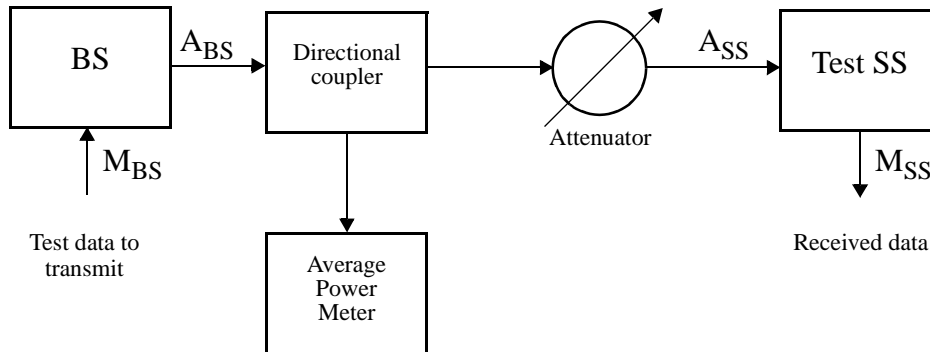

Figure 38—Test setup for Fixed codeword operation

Instruments needed:

- Directional coupler
- Attenuator
- Average power meter

9.2.3.2 Test procedure

The losses for the coupler and the connecting waveguides are measured and the attenuator is calibrated. When measuring the power the losses and the effect of the coupler shall be taken into account.

A connection is setup between the BS and the Test SS. The Test SS requests the BS to use burst profiles with fixed codeword operation.

Data is transmitted in the downlink.

The SS receives the data correctly.

9.2.4 Shortened last codeword operation

9.2.4.1 Test setup

Figure 39 shows the test setup for testing the RS shortened codeword operation.

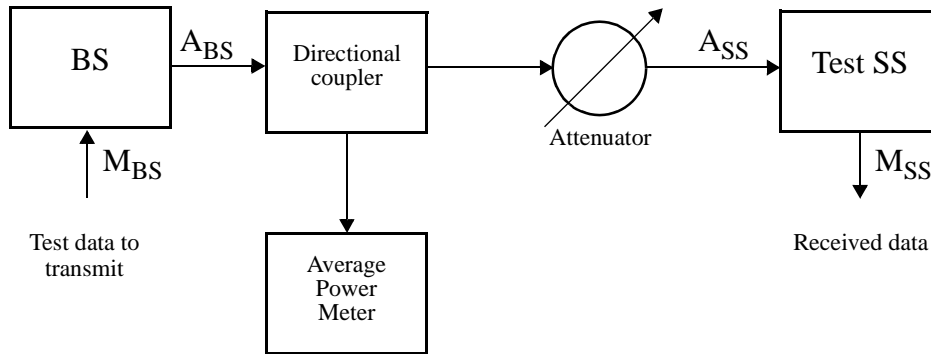

Figure 39—Test setup for Shortened codeword operation

Instruments needed:

- Directional coupler
- Attenuator
- Average power meter

9.2.4.2 Test procedure

The losses for the coupler and the connecting waveguides are measured and the attenuator is calibrated. When measuring the power the losses and the effect of the coupler shall be taken into account.

A connection is setup between the BS and the Test SS. The Test SS requests the BS to use burst profiles with shortened codeword operation.

Data is transmitted in the downlink.

The SS receives the data correctly.

9.2.5 Burst preamble

9.2.5.1 Test setup

Figure 40 shows the test setup for testing the burst preamble.

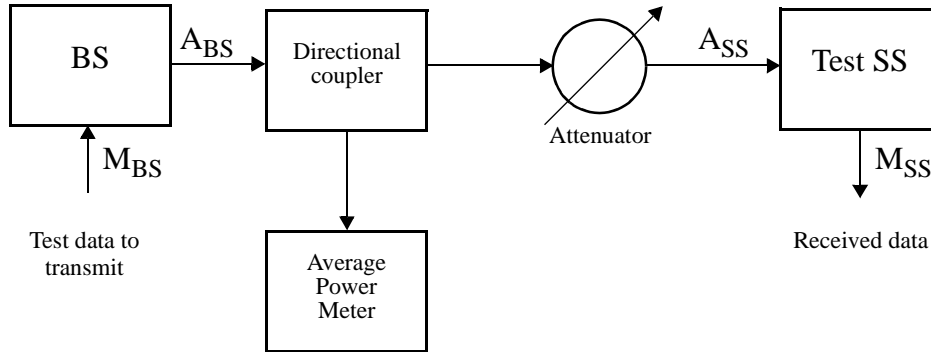

Figure 40—Test setup for burst preamble

Instruments needed: Directional coupler
 Attenuator
 Average power meter

9.2.5.2 Test procedure

The losses for the coupler and the connecting waveguides are measured and the attenuator is calibrated. When measuring the power the losses and the effect of the coupler shall be taken into account.

A connection is setup between the Test BS and the half-duplex Test SS.

Data is transmitted in the TDMA portion of the downlink

The SS receives the data correctly.

9.2.6 Modulation

9.2.6.1 Test setup

Figure 41 shows the test setup for testing the modulation.

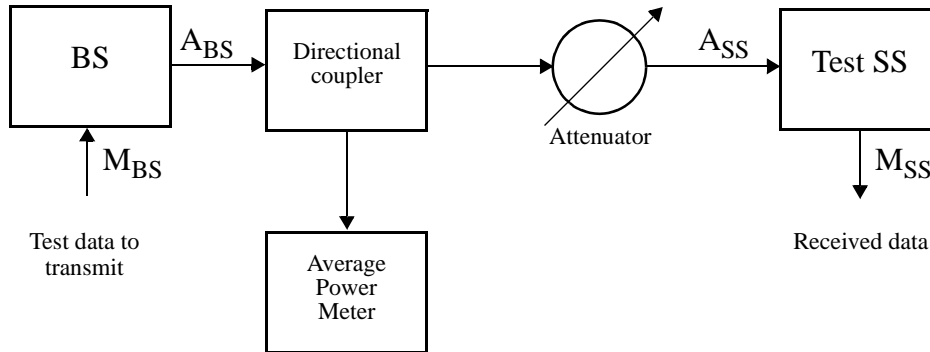

Figure 41—Test setup for modulation

Instruments needed:

- Directional coupler
- Attenuator
- Average power meter

9.2.6.2 Test procedure

The losses for the coupler and the connecting waveguides are measured and the attenuator is calibrated. When measuring the power the losses and the effect of the coupler shall be taken into account.

A connection is setup between the BS and the Test SS. The Test SS requests the BS to use burst profiles with different modulation schemes supported by the BS.

The downlink frame is filled with bursts of test data. The received power is adjusted until the S/N is 10 dB above the actual thresholds.

The SS receives the data correctly.

9.2.7 RS outer code - Information Block Length

9.2.7.1 Test setup

Figure 42 shows the test setup for testing the RS outer code - Information Block Length.

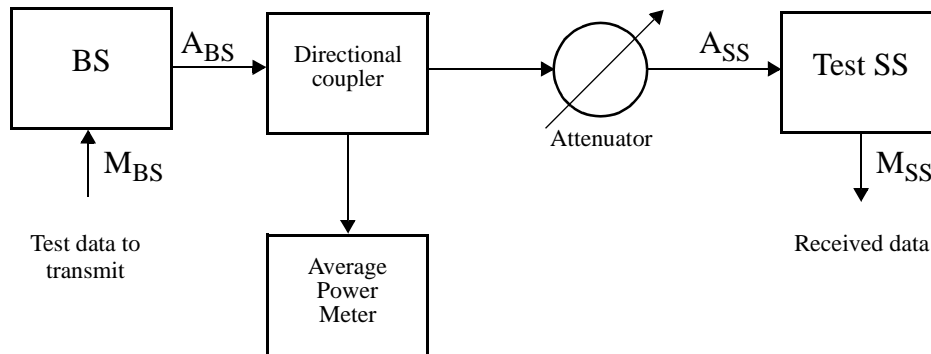

Figure 42—Test setup for RS outer code - Information Block Length

Instruments needed:

- Directional coupler
- Attenuator
- Average power meter

9.2.7.2 Test procedure

The losses for the coupler and the connecting waveguides are measured and the attenuator is calibrated. When measuring the power the losses and the effect of the coupler shall be taken into account.

A connection is setup between the BS and the Test SS. QPSK modulation, no BCC coding, RS coding with information block length = 6, 128, 239 and $t = 8$ are used.

The downlink frame is filled with bursts of test data. The received power is adjusted until the S/N is 10 dB above the actual threshold.

The SS shall receive the data correctly.

9.2.8 Randomization with programmable seed

9.2.8.1 Test setup

Figure 43 shows the test setup for randomization with programmable seed.

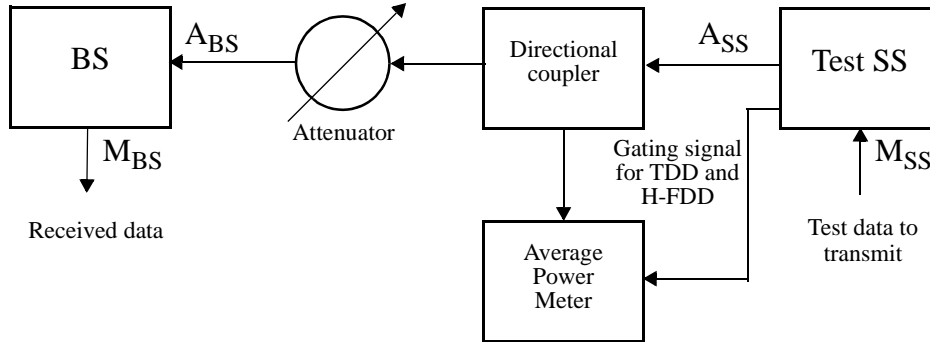

Figure 43—Test setup for randomization with programmable seed

Instruments needed:

- Directional coupler
- Attenuator
- Average power meter

9.2.8.2 Test procedure

The losses for the coupler and the connecting waveguides are measured and the attenuator is calibrated. When measuring the power the losses and the effect of the coupler shall be taken into account.

A connection is setup between the BS and the Test SS. Various UL burst profiles are defined differeng only in their seed values. The test NMS requests the BS to use burst profiles with different seed values for the randomization.

Data is transmitted in the uplink.

The BS receives the data correctly.

9.2.9 RS outer code - Initial ranging

9.2.9.1 Test setup

Figure 44 shows the test setup for testing the RS outer code - Initial ranging.

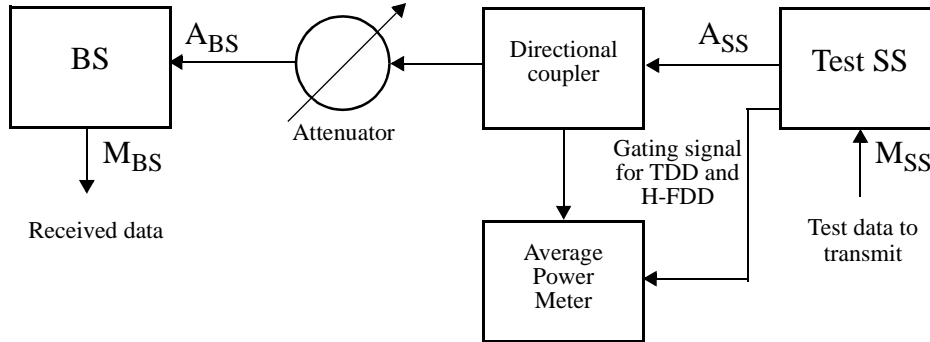

Figure 44—Test setup for RS outer code - Initial ranging

Instruments needed: Directional coupler
 Attenuator
 Average power meter

9.2.9.2 Test procedure

The losses for the coupler and the connecting waveguides are measured and the attenuator is calibrated. When measuring the power the losses and the effect of the coupler shall be taken into account.

A connection is setup between the BS and the Test SS.

The test NMS requests the BS to use burst profiles with RS parameter $t = 10$.

Data is transmitted in the uplink. The Test BS receives the data correctly.

9.2.10 RS outer code other bursts

9.2.10.1 Test setup

Figure 45 shows the test setup for testing the RS outer code other bursts.

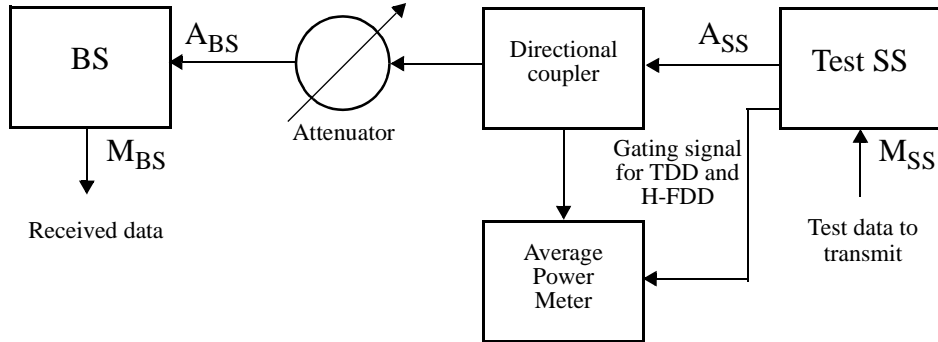

Figure 45—Test setup for RS outer code other bursts

Instruments needed:

- Directional coupler
- Attenuator
- Average power meter

9.2.10.2 Test procedure

The losses for the coupler and the connecting waveguides are measured and the attenuator is calibrated. When measuring the power the losses and the effect of the coupler shall be taken into account.

A connection is setup between the BS and the Test SS. The test NMS requests the BS to use burst profiles with the RS parameter $t = 0, 4, 8$ or 12 , and information bytes 128 are used.

The uplink frame is filled with bursts of test data. The data received at the BS is checked for correctness.

The Test SS inserts alternatively $0, 4, 8$ or 12 erroneous bytes in the codeword corresponding to $t = 0, 4, 8$ and 12 . The BS shall receive the data correctly.

The Test SS inserts alternatively $1, 5, 9$ or 13 erroneous bytes in the codeword corresponding to $t = 0, 4, 8$ and 12 . The BS shall not be able to receive the data correctly.

9.2.11 Fixed codeword operation

9.2.11.1 Test setup

Figure 46 shows the test setup for testing the RS fixed codeword operation.

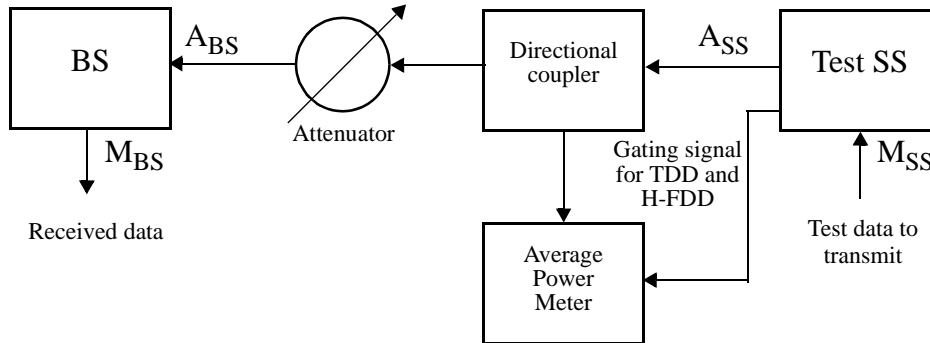

Figure 46—Test setup for Fixed codeword operation

Instruments needed:

- Directional coupler
- Attenuator
- Average power meter

9.2.11.2 Test procedure

The losses for the coupler and the connecting waveguides are measured and the attenuator is calibrated. When measuring the power the losses and the effect of the coupler shall be taken into account.

A connection is setup between the BS and the Test SS. The test NMS requests the BS to use burst profiles with Reed-Solomon Fixed codeword option, QPSK modulation, no BCC coding, RS coding with $t = 8$ and information bytes = 128.

The uplink frame is filled with bursts of test data. The number of bytes in the uplink frame must be not be a multiple of 128.

The BS receives the data correctly.

9.2.12 Shortened last codeword operation

9.2.12.1 Test setup

Figure 47 shows the test setup for testing the RS shortened codeword operation.

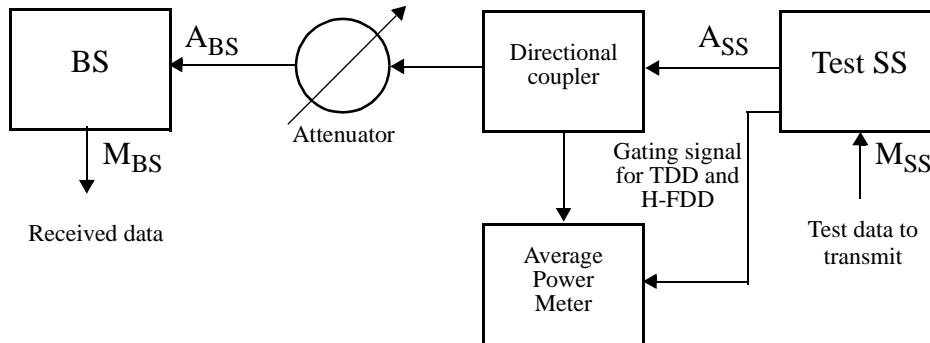

Figure 47—Test setup for Shortened codeword operation

Instruments needed:

- Directional coupler
- Attenuator
- Average power meter

9.2.12.2 Test procedure

The losses for the coupler and the connecting waveguides are measured and the attenuator is calibrated. When measuring the power the losses and the effect of the coupler shall be taken into account.

A connection is setup between the BS and the Test SS. The test NMS requests the BS to use burst profiles with Reed-Solomon Shortened codeword option, QPSK modulation, no BCC coding, RS coding with $t = 8$ and information bytes = 128.

The uplink frame is filled with bursts of test data. The number of bytes in the uplink frame must be not be a multiple of 128.

The BS receives the data correctly.

9.2.13 BCC inner code

9.2.13.1 Test setup

Figure 48 shows the test setup for testing the BCC innercode operation.

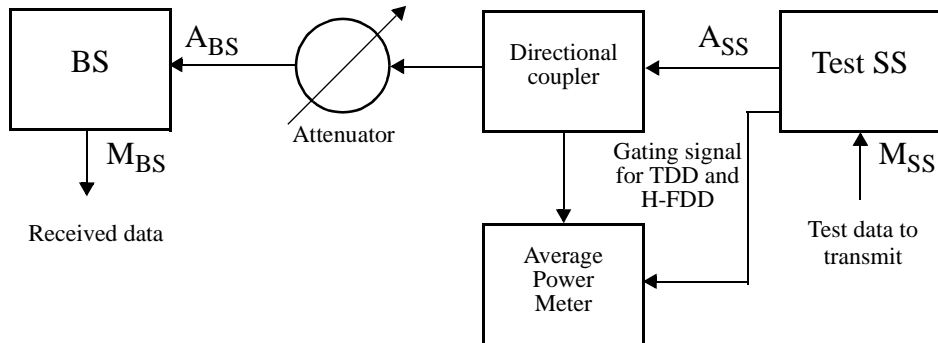

Figure 48—Test setup for BCC inner code operation

Instruments needed:

- Directional coupler
- Attenuator
- Average power meter

9.2.13.2 Test procedure

The losses for the coupler and the connecting waveguides are measured and the attenuator is calibrated. When measuring the power the losses and the effect of the coupler shall be taken into account.

A connection is setup between the BS and the Test SS. The test NMS requests the BS to use a burst profile with BCC inner code.

Data is transmitted in the uplink.

The BS receives the data correctly.

9.2.14 Burst preamble

9.2.14.1 Test setup

Figure 49 shows the test setup for testing the burst preamble.

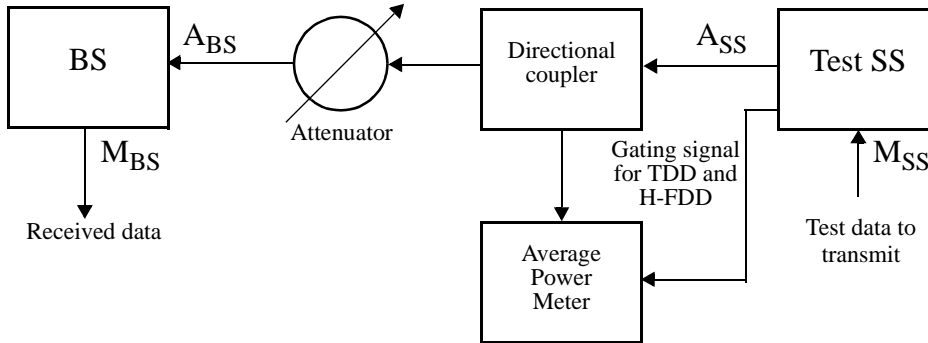

Figure 49—Test setup for burst preamble

Instruments needed:

- Directional coupler
- Attenuator
- Average power meter

9.2.14.2 Test procedure

The losses for the coupler and the connecting waveguides are measured and the attenuator is calibrated. When measuring the power the losses and the effect of the coupler shall be taken into account.

A connection is setup between the BS and the Test SS. The test NMS requests the BS to use burst profiles with different preamble lengths.

Data is transmitted in the uplink.

The BS receives the data correctly.

9.2.15 Modulation

9.2.15.1 Test setup

Figure 50 shows the test setup for testing the modulation schemes.

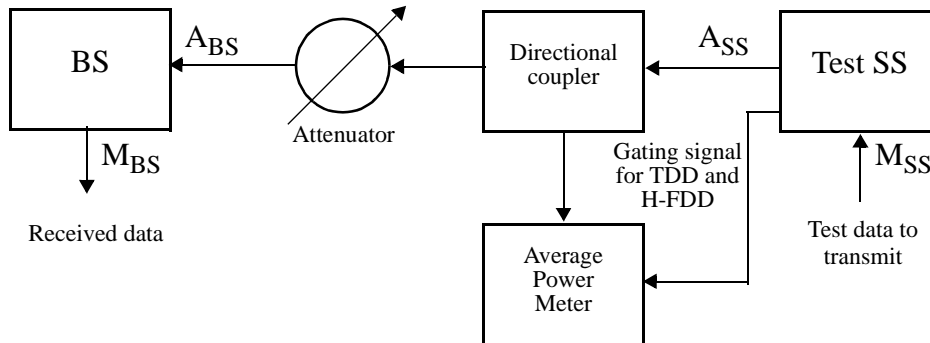

Figure 50—Test setup for the modulation schemes

Instruments needed:

- Directional coupler
- Attenuator
- Average power meter

9.2.15.2 Test procedure

The losses for the coupler and the connecting waveguides are measured and the attenuator is calibrated. When measuring the power the losses and the effect of the coupler shall be taken into account.

A connection is setup between the BS and the Test SS. The test NMS requests the BS to use burst profiles with the different modulation schemes supported by the SS.

Data is transmitted in the uplink.

The BS receives the data correctly.

9.2.16 RS outer code - Information Block Length

9.2.16.1 Test setup

Figure 51 shows the test setup for testing the RS outer code - Information Block Length.

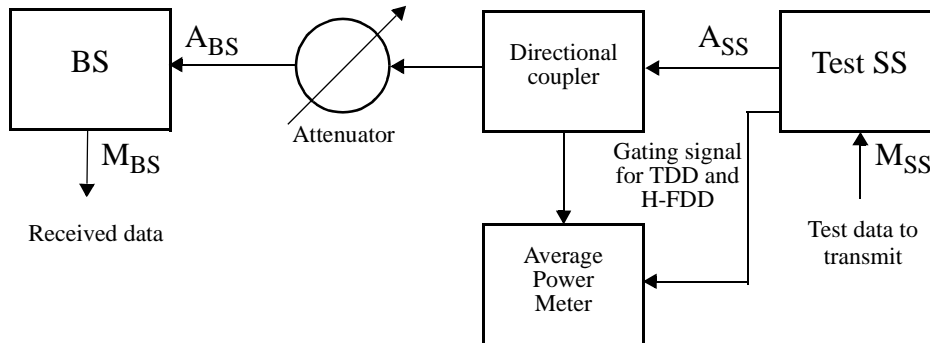

Figure 51—Test setup for RS outer code - Information Block Length

Instruments needed:

- Directional coupler
- Attenuator
- Average power meter

9.2.16.2 Test procedure

The losses for the coupler and the connecting waveguides are measured and the attenuator is calibrated. When measuring the power the losses and the effect of the coupler shall be taken into account.

A connection is setup between the BS and the Test SS. The test NMS requests the BS to use burst profiles with the the RS parameter Information block length = 6, 128 and 239. RS parameter $t = 8$.

Data is transmitted in the uplink.

The BS receives the data correctly.

9.2.17 Channel allocation

9.2.17.1 Test setup

Figure 52 shows the test setup for testing the channel allocation.

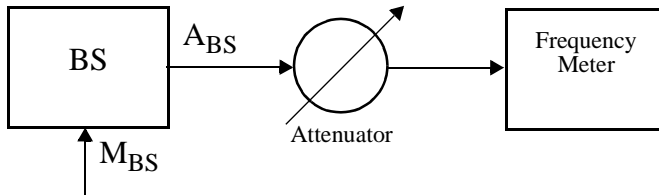

Figure 52—Test setup for Channel allocation

Instruments needed: Attenuator
 Frequency meter

9.2.17.2 Test procedure

The BS is set in the CW test mode. The attenuator is adjusted for an optimal reception level.

The BS is requested to generate frequencies which are multiples of 250 kHz in the frequency range declared by the manufacturer

The BS is able to generate frequencies which are multiples of 250 kHz.

1 **9.2.18 Symbol timing accuracy**

2
3 **9.2.18.1 Test setup**

4
5
6 Figure 53 shows the test setup for testing the symbol timing accuracy.

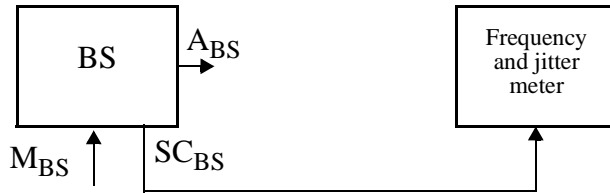

24 **Figure 53—Test setup for symbol timing accuracy**

25
26
27 Instruments needed: Frequency meter
28 Jitter meter

29
30
31 **9.2.18.2 Test procedure**

32
33 The BS is operable and the symbol clock frequency and jitter are measured.

34
35 The symbol clock accuracy shall be within +/-15 ppm of its nominal value. The peak-to-peak jitter of the
36 symbol clock during a 2 sec measurement period shall be less than 2 %.

9.2.19 Carrier frequency

9.2.19.1 Test setup

Figure 54 shows the test setup for testing the carrier frequency.

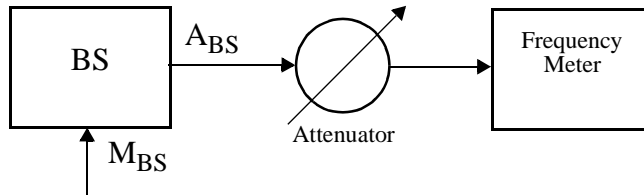

Figure 54—Test setup for Carrier frequency

Instruments needed: Attenuator
 Frequency meter

9.2.19.2 Test procedure

The BS is set in the CW test mode. The attenuator is adjusted for an optimal reception level

The BS is requested to generate frequencies which are multiples of 250 KHz in frequency range declared by the manufacturer

The accuracy shall be better than +/- 10 ppm.

9.2.20 Spectral mask

9.2.20.1 Test setup

Figure 55 shows the test setup for testing the spectral mask.

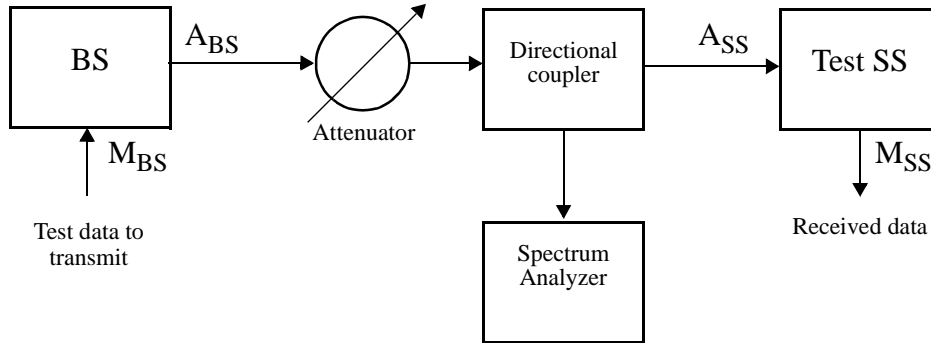

Figure 55—Test setup for Spectral mask

Instruments needed: Attenuator
 Spectrum Analyzer

9.2.20.2 Test procedure

A connection is setup between the BS and the Test SS. The downlink frame is filled with QPSK modulated data.

The spectrum is measured with a spectrum analyzer. The spectrum shall not exceed the mask given by the local regulator.

The settings of the spectrum analyzer shall be according to table 9

Table 9—Spectrum analyzer settings

Paramter	SS
Center frequency	Actual
Span	140 MHz
Scan time	Auto
Resolution bandwidth	300 KHz
Video bandwidth	100 KHz

1
2
3
4
5
6
7
8
9
10
11
12
13
14
15
16
17
18
19
20
21
22
23
24
25
26
27
28
29
30
31
32
33
34
35
36
37
38
39
40
41
42
43
44
45
46
47
48
49
50
51
52
53
54
55
56
57
58
59
60
61
62
63
64
65

9.2.21 Spurious

9.2.21.1 Test setup

Figure 56 shows the test setup for testing the spurious frequencies.

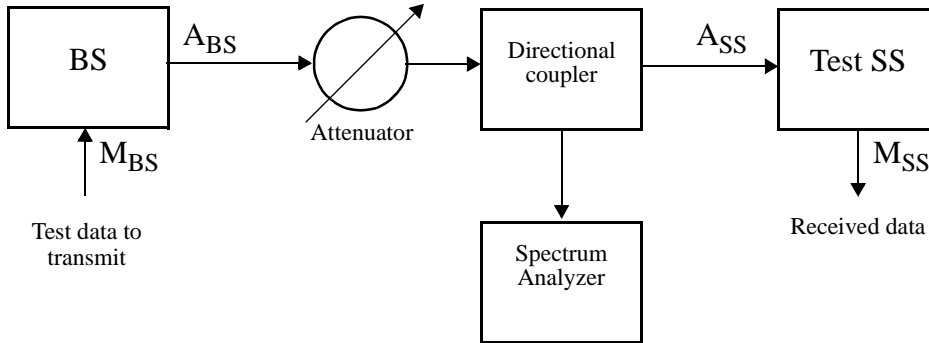

Figure 56—Test setup for Spurious frequencies

Instruments needed: Attenuator
 Spectrum Analyzer

9.2.21.2 Test procedure

A connection is setup between the BS and the Test SS. The downlink frame is filled with QPSK modulated data.

The spectrum is measured with a spectrum analyzer. The spurious frequencies shall not exceed the values given by the local regulator.

The settings of the spectrum analyzer shall be according to table 10

Table 10—Spectrum analyzer settings

Paramter	SS
Center frequency	Actual
Span	140 MHz
Scan time	Auto
Resolution bandwidth	TBD
Video bandwidth	TBD

9.2.22 Tx RMS Power level

9.2.22.1 Test setup

Figure 57 shows the test setup for testing the Tx RMS Power level

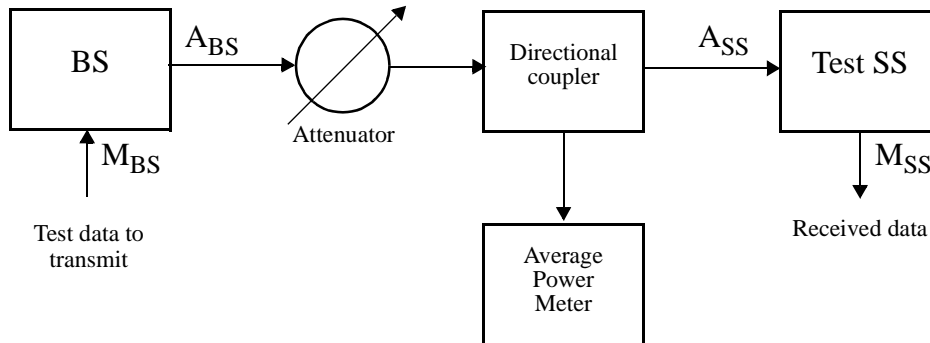

Figure 57—Test setup for Tx RMS power level

Instruments needed:

- Directional coupler
- Attenuator
- Average power meter

9.2.22.2 Test procedure

The losses for the coupler and the connecting waveguides are measured and the attenuator is calibrated. When measuring the power the losses and the effect of the coupler shall be taken into account.

A connection is setup between the BS and the Test SS. The Test SS requests the BS to use the most robust burst profile. The downlink is filled with data.

The power is measured.

The power shall be = declared value +/- 2 dB.

9.2.23 Ramp up / down time

9.2.23.1 Test setup

Figure 58 shows the test setup for testing the Ramp up / down time.

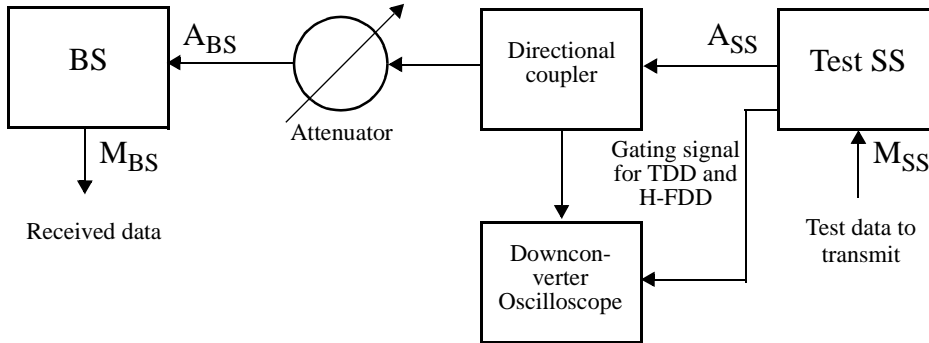

Figure 58—Test setup for Ramp up / down time

Instruments needed:

- Directional coupler
- Attenuator
- Average power meter

9.2.23.2 Test procedure

The losses for the coupler and the connecting waveguides are measured and the attenuator is calibrated. When measuring the power the losses and the effect of the coupler shall be taken into account.

A connection is setup between the BS and the Test SS. Data is transmitted in the uplink with QPSK modulation.

The BS allows ≥ 24 symbols ramp up and ramp down times, including allowances for round trip delay when creating the maps.

9.2.24 Modulation accuracy

9.2.24.1 Test setup

Figure 59 shows the test setup for testing the modulation accuracy.

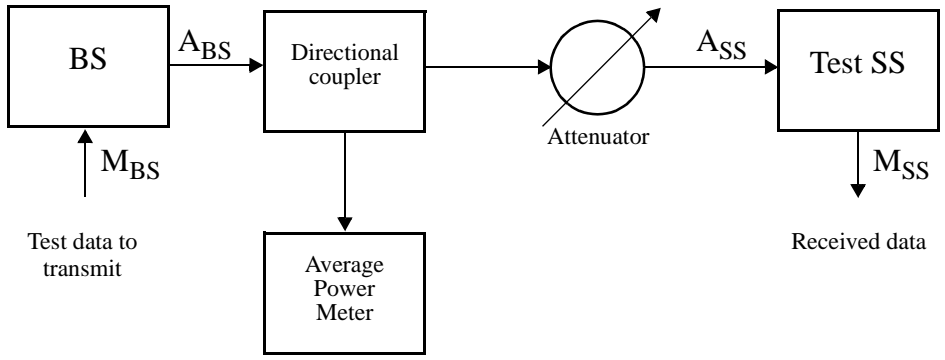

Figure 59—Test setup for Modulation accuracy

Instruments needed: Directional coupler
 Attenuator
 Average power meter

9.2.24.2 Test procedure

The losses for the coupler and the connecting waveguides are measured and the attenuator is calibrated. When measuring the power the losses and the effect of the coupler shall be taken into account.

The sensitivity value P for the Test SS for BER=10⁻³ is measured using a high quality transmitter as the signal source.

The sensitivity value M for the Test SS for BER=10⁻³ is measured using the BS as the signal source. The difference M - P shall be less than or equal to the values in column 2 in table 11

Table 11—EVM requirements

	Tx implementation margin	EVM no equalizer	EVM equalizer
QPSK	0.5 dB	12 %	10 %
16-QAM	1.0 dB	6 %	3 %
64-QAM	1.5 dB		1.5 %

1
2
3
4
5
6
7
8
9
10
11
12
13
14
15
16
17
18
19
20
21
22
23
24
25
26
27
28
29
30
31
32
33
34
35
36
37
38
39
40
41
42
43
44
45
46
47
48
49
50
51
52
53
54
55
56
57
58
59
60
61
62
63
64
65

9.2.25 Rx Dynamic range

9.2.25.1 Test setup

Figure 60 shows the test setup for testing the Rx Dynamic Range

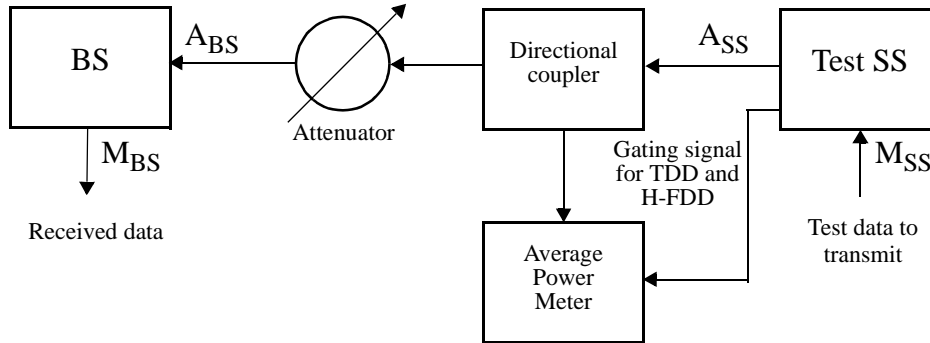

Figure 60—Test setup for Rx Dynamic Range

Instruments needed: Directional coupler
 Attenuator
 Average power meter

9.2.25.2 Test procedure

The losses for the coupler and the connecting waveguides are measured and the attenuator is calibrated. When measuring the power the losses and the effect of the coupler shall be taken into account.

A connection is setup between the BS and the Test SS. The test NMS requests the BS to use the most robust burst profile. Data is transmitted in the uplink.

The attenuator is adjusted until the minimum operable value is reached. The power of the received signal is measured and recorded. The attenuator is then increased until the the maximum operable value is reached. The power is measured and recorded.

The difference between the two power values is the Rx dynamic range and shall be ≥ 27 dB.

9.2.26 BER performance threshold

9.2.26.1 Test setup

Figure 61 shows the test setup for testing the BER performance threshold.

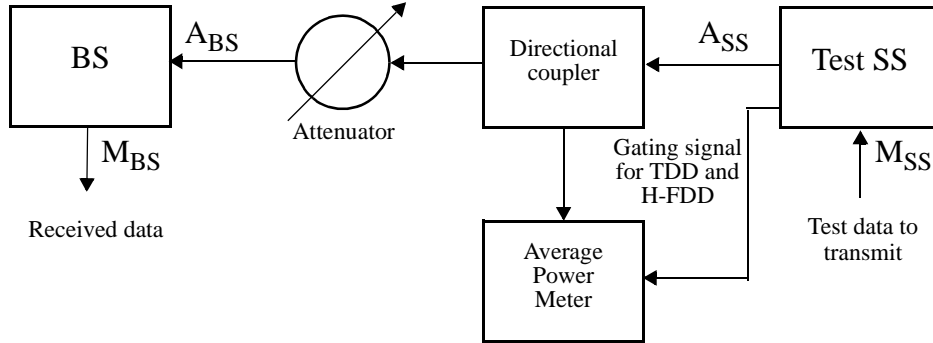

Figure 61—Test setup for BER performance threshold

Instruments needed: Directional coupler
 Attenuator
 Average power meter

9.2.26.2 Test procedure

The losses for the coupler and the connecting waveguides are measured and the attenuator is calibrated. When measuring the power the losses and the effect of the coupler shall be taken into account.

A connection is setup between the BS and the Test SS. The Test SS transmits the bursts with all supported modulation schemes and no FEC. CRC is disabled

The BER is computed from the payload of the data packets accepted by the BS. The attenuator is adjusted until $BER = 10^{-3}$ and then 10^{-6} . The input power is measured and shall be according to table 12. B is the symbol rate in MBaud.

Table 12—BER performance threshold sensitivity values

	BER 10^{-3}	BER 10^{-6}
QPSK	$-94 + 10\log(B)$ dBm	$-90 + 10\log(B)$ dBm
16-QAM	$-87 + 10\log(B)$ dBm	$-83 + 10\log(B)$ dBm
64-QAM	$-79 + 10\log(B)$ dBm	$-74 + 10\log(B)$ dBm

9.2.27 1st adjacent channel interference

9.2.27.1 Test setup

Figure 62 shows the test setup for testing the 1st adjacent channel interference.

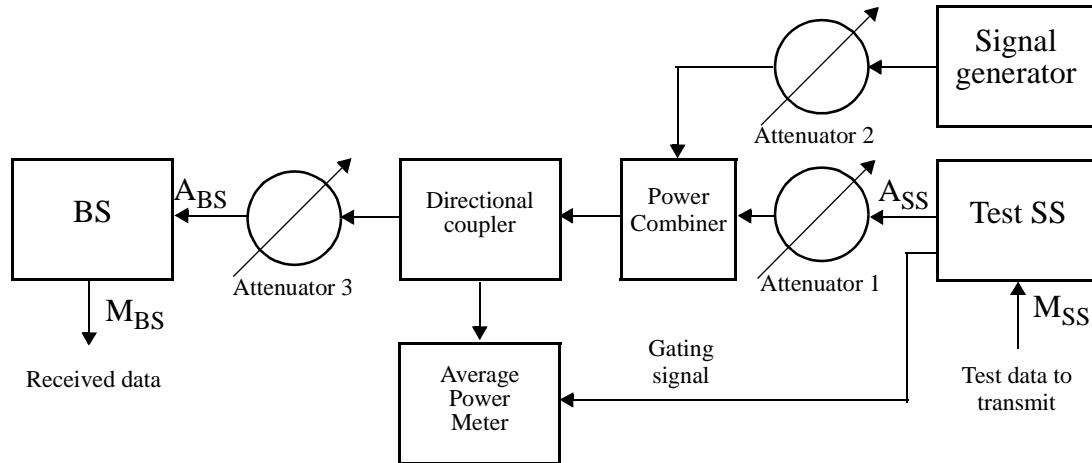

Figure 62—Test setup for 1st adjacent channel interference

Instruments needed:

- Directional coupler
- Attenuators
- Average power meter
- Power combiner

9.2.27.2 Test procedure

The losses for the coupler and the connecting waveguides are measured and the attenuators are calibrated. When measuring the power the losses and the effect of the coupler shall be taken into account. Attenuators 1 and 2 are used to adjust the ratio between the useful and interfering signals. Attenuator 3 is used for adjusting the absolute signal level at the receiver and can be held at a constant value of 10 dB. The signal generator transmits a similar signal as the useful signal on the first adjacent channel.

A connection is setup between the BS and the Test SS. Attenuator 2 is set to its maximum value and the signal generator is switched off. The uplink frame is filled with QPSK modulated data and attenuator 1 is adjusted for BER = 10^{-3} (10^{-6}). The signal power is increased by 3 (1) dB and the power is measured.

The signal generator is switched on and attenuator 2 is decreased until BER = 10^{-3} (10^{-6}) is achieved. The Test BS is turned off and the power of the interfering signal is measured.

The procedure is repeated for the other modulation schemes, 1 dB degradation and BER = 10^{-6} . The C/I values shall be according to tables 13 and 14.

1
2
3
4
5
6
7
8
9
10
11
12
13
14
15
16
17
18
19
20
21
22
23
24
25
26
27
28
29
30
31
32
33
34
35
36
37
38
39
40
41
42
43
44
45
46
47
48
49
50
51
52
53
54
55
56
57
58
59
60
61
62
63
64
65**Table 13—1st adjacent channel interference BER 10^{-3}**

	1 dB degradation	3 dB degradation
QPSK	-5 dB	-9 dB
16-QAM	+2 dB	-2 dB
64-QAM	+9 dB	+5 dB

Table 14—1st adjacent channel interference BER= 10^{-6}

	1 dB degradation	3 dB degradation
QPSK	-1 dB	-5 dB
16-QAM	+6 dB	+2 dB
64-QAM	+13 dB	+9 dB

9.2.28 2nd adjacent channel interference

9.2.28.1 Test setup

Figure 63 shows the test setup for testing the 2nd adjacent channel interference.

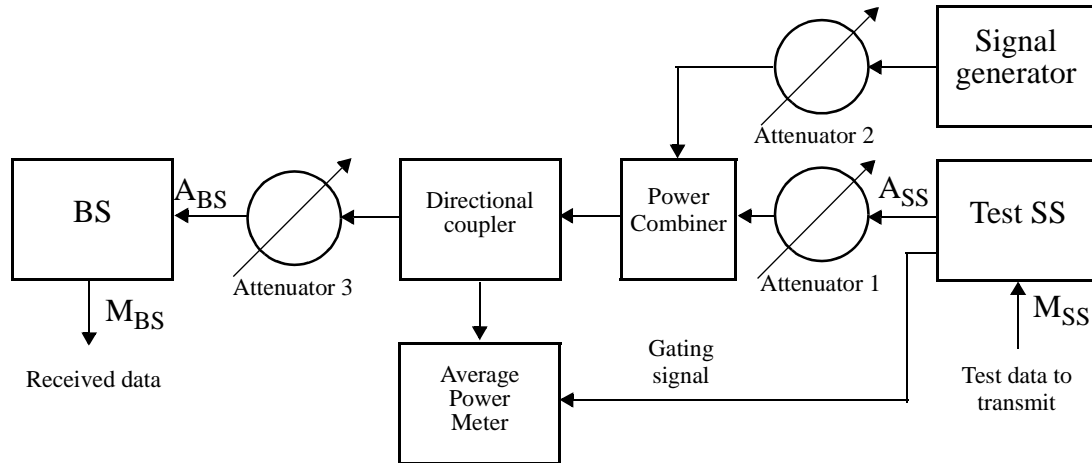

Figure 63—Test setup for 2nd adjacent channel interference

Instruments needed:

- Directional coupler
- Attenuators
- Average power meter
- Power combiner

9.2.28.2 Test procedure

The losses for the coupler and the connecting waveguides are measured and the attenuators are calibrated. When measuring the power the losses and the effect of the coupler shall be taken into account. Attenuators 1 and 2 are used to adjust the ratio between the useful and interfering signals. Attenuator 3 is used for adjusting the absolute signal level at the receiver and can be held at a constant value of 10 dB. The signal generator transmits a similar signal as the useful signal on the second adjacent channel.

A connection is setup between the BS and the Test SS. Attenuator 2 is set to its maximum value and the signal generator is switched off. The uplink frame is filled with QPSK modulated data and attenuator 1 is adjusted for $BER = 10^{-3}$ (10^{-6}). The signal power is increased by 3 (1) dB and the power is measured.

The signal generator is switched on and attenuator 2 is decreased until $BER = 10^{-3}$ (10^{-6}) is achieved. The Test BS is turned off and the power of the interfering signal is measured.

The procedure is repeated for the other modulation schemes, 1 dB degradation and $BER = 10^{-6}$. The C/I values shall be according to tables 15 and 16.

Table 15—2nd adjacent channel interference BER 10^{-3}

	1 dB degradation	3 dB degradation
QPSK	-30 dB	-34 dB
16-QAM	-22 dB	-27 dB
64-QAM	-16 dB	-20 dB

Table 16—2nd adjacent channel interference BER= 10^{-6}

	1 dB degradation	3 dB degradation
QPSK	-26 dB	-30 dB
16-QAM	-20 dB	-23 dB
64-QAM	-12 dB	-16 dB

10. Annex A

10.1 Requirements for the test laboratories

11. Test equipment

The following equipment is needed for the tests and shall be provided by the test laboratory:

Terminal for system configuration (parameter setting) and control;

RF-Adapter

Spectrum Analyzer

Variable RF-Attenuator

Power meter

Oscilloscope

Printer, Plotter

1
2
3
4
5
6
7
8
9
10
11
12
13
14
15
16
17
18
19
20
21
22
23
24
25
26
27
28
29
30
31
32
33
34
35
36
37
38
39
40
41
42
43
44
45
46
47
48
49
50
51
52
53
54
55
56
57
58
59
60
61
62
63
64
65

12. General test platform

13. Carrier frequencies