

Project	<b>IEEE 802.16 Broadband Wireless Access Working Group</b> < <a href="http://ieee802.org/16">http://ieee802.org/16</a> >	
Title	<b>Complementary document for draft comments</b>	
Date Submitted	<b>2004-01-13</b>	
Source(s)	Yossi Segal Itzik Kitroser Yigal Leiba Zion Hadad Runcom Technologies Ltd. 2 Hachoma St. 75655 Rishon Lezion, Israel	Voice: +972-3-9528440 Fax: +972-3-9528805 <a href="mailto:yossis@runcom.co.il">yossis@runcom.co.il</a> <a href="mailto:itzikk@runcom.co.il">itzikk@runcom.co.il</a> <a href="mailto:yigall@runcom.co.il">yigall@runcom.co.il</a> <a href="mailto:zionh@runcom.co.il">zionh@runcom.co.il</a>
Re:	Contribution elaborating on comments for letter ballot #13a	
Abstract	This document includes text referenced in several comments given for ballot 13a	
Purpose	To be integrated into P80216-REVd_D2 document	
Notice	This document has been prepared to assist IEEE 802.16. It is offered as a basis for discussion and is not binding on the contributing individual(s) or organization(s). The material in this document is subject to change in form and content after further study. The contributor(s) reserve(s) the right to add, amend or withdraw material contained herein.	
Release	The contributor grants a free, irrevocable license to the IEEE to incorporate material contained in this contribution, and any modifications thereof, in the creation of an IEEE Standards publication; to copyright in the IEEE's name any IEEE Standards publication even though it may include portions of this contribution; and at the IEEE's sole discretion to permit others to reproduce in whole or in part the resulting IEEE Standards publication. The contributor also acknowledges and accepts that this contribution may be made public by IEEE 802.16.	
Patent Policy and Procedures	The contributor is familiar with the IEEE 802.16 Patent Policy and Procedures < <a href="http://ieee802.org/16/ipr/patents/policy.html">http://ieee802.org/16/ipr/patents/policy.html</a> >, including the statement "IEEE standards may include the known use of patent(s), including patent applications, provided the IEEE receives assurance from the patent holder or applicant with respect to patents essential for compliance with both mandatory and optional portions of the standard." Early disclosure to the Working Group of patent information that might be relevant to the standard is essential to reduce the possibility for delays in the development process and increase the likelihood that the draft publication will be approved for publication. Please notify the Chair < <a href="mailto:chair@wirelessman.org">mailto:chair@wirelessman.org</a> > as early as possible, in written or electronic form, if patented technology (or technology under patent application) might be incorporated into a draft standard being developed within the IEEE 802.16 Working Group. The Chair will disclose this notification via the IEEE 802.16 web site < <a href="http://ieee802.org/16/ipr/patents/notices">http://ieee802.org/16/ipr/patents/notices</a> >.	

# Complementary document for ballot 13a comments

*Yossi Segal  
Yigal Leiba  
Itzik Kitroser  
Zion Hadad  
Runcom*

## 1 Introduction

The following contribution contains the relevant information that should be changed in the appropriate sections. This document is referenced by several comments.

### 1.1 FCH Related

- Page 449 line 63 – 8.4.3.2. OFMDA data mapping

1) Segment the data into blocks sized to fit into one FEC block.

2) Each FEC block may span several subchannel in the subchannel axis and one or two OFDMA symbols in the time axis (see Figure 210). In addition, when mini-subchannels are employed for the uplink ~~direction~~, each FEC block may span several mini-subchannel in the mini-subchannel axis and blocks of three OFDMA symbols in the time axis (see Figure 209). The size of the allocation depends on the configuration used  
PUSC - FEC blocks are not allowed to span more than the basic burst allocation, and concatenation of FEC blocks is not allowed when repetition coding is used

FUSC – a FEC block may span over more than the basic burst time, and concatenation is allowed in any repetition coding. The FEC blocks are mapped such that the lowest numbered FEC block occupies the lowest numbered subchannel in the lowest numbered OFDMA symbol.

3) Continue the mapping such that the subchannel index is increased, ~~for each FEC block mapped~~. When the edge of the Data Region is reached, continue the mapping from the lowest numbered subchannel in the next time burst.

- Page 451 line 57 – 8.4.4.2 PMP frame structure

by multiples of one (or two, if STC is used, see 8.4.8) OFDMA symbol.

- Page 452 figure 211

Change the number of sub-channels allocated to the FCH to 2 (instead of 3)

- Page 452 line 38

Subchannel allocation per transmitter in the downlink may be performed in one of the following ways: partial usage of subchannels (PUSC) where some of the subchannels are allocated to the transmitter, and full usage of the subchannels (FUSC) where all subchannels are allocated to the transmitter. The first two ~~three~~ transmitted subchannels in the first data symbol of the downlink is called FCH. In PUSC, the FCH is transmitted using QPSK rate  $\frac{1}{2}$ , with two repetitions using the mandatory coding scheme (e.g. the FCH information will be sent on two adjacent subchannels). In FUSC, the FCH is transmitted using QPSK rate  $\frac{1}{2}$  using the mandatory coding scheme and with a repetition coding of 6. The FCH contains the DL\_Frame Prefix as described in section 8.4.4.4, and specifies the length of the DL\_MAP message that

immediately follow the DL\_Frame\_Prefix, and the repetition coding used for the DL-MAP message. Note that the DL-MAP message may 'spill' over into the first downlink burst.

With exception of the map messages, no MAC PDUs shall be split over multiple consecutive bursts with different burst profiles.

- Page 453 table 224 – 8.4.4.4. DL frame prefix

Syntax	Size	Notes
DL_Frame_Prefix_Format() {		
<b>Sub_Channels_Bitmap</b>	32 bits	
<b>Midambles_Used</b>	1 bits	0 - No midambles on downlink 1 - Optional midambles used in downlink
<b>Ranging_Change_Indication</b>	1 bits	
<b>Repetition_Coding_Indication</b>	1 bits	<u>Repetition coding used</u> <u>0 – No repetition coding for PUSC/</u> <u>repetition coding of 4 for FUSC</u> <u>1 – repetition coding of 2 for PUSC/</u> <u>repetition coding of 6 for FUSC</u>
<b>DL_Map_Length</b>	56 bits	
<b>Prefix_CS</b>	8 bits	
}		

#### **Repetition\_Coding\_Indication**

Indication for the rate of the repetition coding used for different modes of operation:

0 – No repetition coding for PUSC/ repetition coding of 4 for FUSC

1 – repetition coding of 2 for PUSC/ repetition coding of 6 for FUSC, when using Transmit diversity schemes (section 8.4.8) this indication will be always 1

- page 454 line 14 – 8.4.4.5 Allocation of subchannels for FCH, and logical subchannel numbering

In PUSC, the minimal allocation of subchannels for a segment (if the segment is used) is 53 subchannels. The first two three transmitted subchannels in the first data symbol of the downlink contains contains the FCH as defined in 8.4.4.2 (if repetition encoding is used then the next 2 sub-channels transmit the same data, which is the start of the DL-MAP, if no repetition is used then the next 3 subchannels are concatenated to use a QPSK modulation with a bigger size as indicated in 8.4.9). For segment 0 Subchannels 0-42 are used as the basic allocated Subchannels, for segment 1 Subchannels 11-1543, for segment 2 Subchannels 22-2624, Figure 213 depicts this structure:

- page 454 figure 213

change in figure 213 to indicate that the FCH takes only 2 subchannels and not 3

- page 455 line 1

In FUSC, the first 642 transmitted subchannels in the first data symbol of the downlink contains the FCH as defined in 8.4.4.2 (using QPSK rate 1/2 and repetition coding of 64), for any segment the first 6 sub-channels of the segment shall Subchannels 0-11 contain the FCH. Figure 214 depicts this structure:

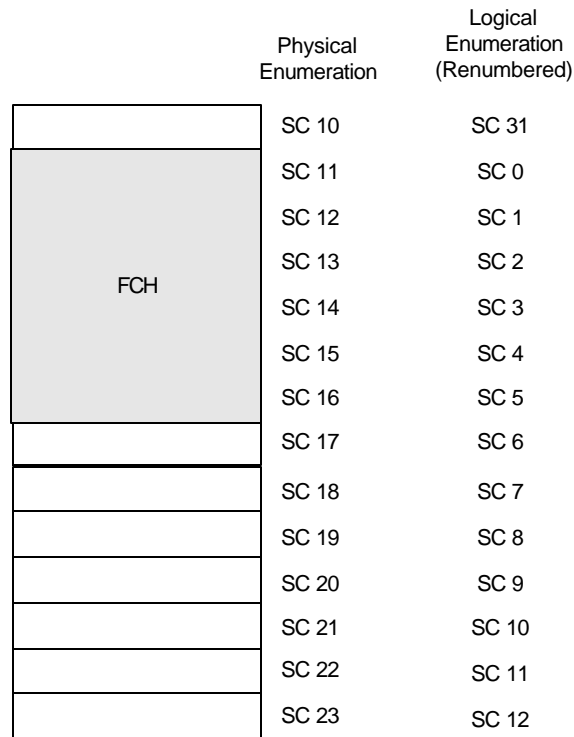

**Figure 214—DL Frame Prefix sub-channel allocation for segment 1 using FUSC**

After decoding the DL\_Frame\_Prefix message within the FCH, the SS has the knowledge of how many (in PUSC) and which subchannels are allocated to the segment, and the knowledge of how many repetitions have been used to modulate the DL-MAP. ~~In the downlink direction,~~ in order to observe the allocation of the subchannels in the downlink as a contiguous block of allocation ~~(in PUSC),~~ the subchannels shall be renumbered, the renumbering shall start from the FCH subchannels (renumbered to values 0..12 for PUSC and 0..5 for FUSC), then continue numbering the subchannels in a cyclic manner to the last allocated subchannel and from the first allocated subchannel to the FCH Subchannels, Figure 214 and 215 gives an example of such renumbering for segment 1. For uplink allocation purposes, no renumberation is done and the subchannel with the lowest index shall be considered as subchannel 0.

- Page 456 figure 215

Change in the figure the number of allocated subchannels for the FCH to 2 instead of 3

- Page 458 table 226 – replace with

Code (N)	Frame Duration (ms)	Frames Per second
0	N/A	AAS-only gap up to 200 ms following (see 8.4.6.3)
1	2	500
2	2.5	400
3	4	250
4	5	200
5	8	125
6	10	100
7	12.5	80

8	20	50
9-255	Reserved	

## 1.2 STC Related

- Page 458 table 227

Syntax	Size	Notes
DL-MAP_IE() {		
<b>DIUC</b>	4 bits	
if (DIUC==15) {		
Extended DIUC dependent IE	variable	AAS_DL_IE() or TDSTC_IE()
} else {		
<b>OFDMA Symbol offset</b>	10 bits	
<b>Subchannel offset</b>	5 bits	
<b>Boosting</b>	3 bits	000: normal (not boosted); 001: +6dB; 010: -6dB; 011: +9dB; 100: +3dB; 101: -3dB; 110: -9dB; 111: - 12dB;
<b>No. OFDMA Symbols</b>	9 bits	
<b>No. Subchannels</b>	5 bits	
}		
}		

- Page 460 line 26

### 8.4.5.3.3 Transmit Diversity (TD) IE format

In the DL-MAP, an Transmit diversity STC enabled BS (see 8.4.8) may transmit DIUC=15 with the TDSTC\_IE() to indicate that the subsequent allocations shall be Transmit diversity STC encoded. No preceding downlink allocations shall be Transmit diversity STC encoded and all subsequent downlink allocations ~~until the end of the frame~~ shall be Transmit diversity STC encoded. ~~The subsequent downlink allocations shall span a multiple of 6 OFDMA symbols in time.~~

Syntax	Size	Notes
<u>TDSTC_IE()</u> {		
<b>Extended DIUC</b>	4 bits	STC = 0x01, FHDC = 0x02
<b>OFDMA Symbol offset</b>	10 bits	
}		

The duration of the DIUC=15 TDSTC\_IE() allocation shall be zero. ~~All allocations~~ From the start of the frame up to this allocation, ~~shall be transmitted only from one antenna (antenna 0) shall be used.~~ The transmission in this allocation will be as specified in 8.4.8.2. After this allocation, the BS shall transmit all allocations from both its antennas until the end of the allocations ~~frame~~.

- page 469 line 7

The downlink can be divided into a 3 segment structure and includes a preamble which begins the transmission. ~~This preamble divides the used subcarriers into 6 sections~~ This preamble subcarriers are divided into 6 carrier-sets. Each ~~2 carrier-sets sections~~ carrier-sets are used by a single segment. The splitting defined above allows usage of 6 different preambles in the transmit diversity mode ~~Space-Time Coding mode (STC)~~.

- page 509 line 1 – 8.4.6.1.2. Symbol Structure

uses half of the pilot-set resources compared to that of non-STC mode. Table 242 summarizes the parameters of the symbol:

- page 509 line 16 – comment on the number of carrier used

Number of all subcarriers used within a symbol, including all possible allocated pilots and the DC carrier.

- page 509 line 22/49 two commas embedded within the indices
- page 509 line 52 – change VariableSet#5 to ConstantSet#5
- page 510 figure 220 – change left guard band carriers to 172 instead of 173
- page 512 line 11 and page 517 line 16 – 8.4.6.2. Uplink

change number of used subcarriers to 1697 instead of 1696

- page 518 line 24 – 8.4.7.1 Initial-ranging transmissions

The BS can allocate two consecutive initial ranging slots, and onto those the ...

- page 520 line 54

#### **8.4.8 Transmit diversity: ~~Space-time coding~~ (optional)**

Space-Time Coding (STC) (see [B1]) or Frequency hopping diversity coding (FHDC) may be used on the downlink to provide 2nd order (Space) transmit diversity.

There are two transmit antennas on the BS side and one reception antenna on the SS side. This scheme requires multiple input single output channel estimation. Decoding is very similar to maximum ratio combining.

Figure 229 shows Transmit Diversity ~~STC~~ insertion into the OFDM chain. Each Tx antenna has its own OFDM chain, but they have the same Local Oscillator for synchronization purposes.

- page 521 line 22

Both antennas transmit in the same time 2 different OFDM data symbols. Transmission is performed twice to decode and to get 2nd order diversity. Time domain (Space-Time) or Frequency domain (Space-Frequency) repetition is used. This mode of operation allows better performance with higher complexity in the receiver. The mode of operation introduced in the sequel defines a combined operation of the ~~STC~~ Transmit diversity and the mandatory mode. The current SFN mandatory mode of operation allows the splitting of the available Subchannels into 3 segments, each transmitting some (or all) of the Subchannels as allocated by the system management. The Transmit diversity ~~STC~~ mode of operation shall be used in a combined way with the regular mode of operation; this is performed by allocating subchannels to either modes of operation. ~~by using it's own allocated set of~~

~~Subchannels, this will result in a possible splitting of the Subchannels to 6 different allocations:~~

~~— Allocations for regular use~~

~~— Allocations for STC use~~

The regular Subchannel transmission in the downlink shall be performed from only one antenna (Antenna 0)

while the Transmit diversity STC Subchannels transmission shall be performed from both antennas obeying the formulas in 8.4.8.2.

- page 521 line 53

add section 8.4.8.2 Space Time Coding, and change the current 8.4.8.2 to 8.4.8.2.1

- page 521 line 55

The basic scheme [B1] transmits 2 complex symbols  $s_1$  and  $s_2$ , using the multiple input single output channel (two Tx, one Rx) ~~twice~~ with channel vector values (for antenna 0) and (for antenna 1).

- page 522 line 13

Figure 230 shows STC for OFDMA, the figure illustrates how an STC transmission shall be performed (it shall be noted that when regular transmission is performed data subchannels are transmitted from antenna 0 only). Note that since pilot positions do not change from even to odd symbols, and pilot modulation is real, conjugation (and inversion) can be applied to a whole symbol (possibly in the time domain).

- page 521 line 53

change section numbering 8.4.8.3 to 8.4.8.2.2

- page 522 line 58

change section number 8.4.8.4 to 8.4.8.2.3

- page 522 line 60

The downlink shall enable the co-transmission of regular Subchannel transmission and STC Subchannel transmission as explained in 8.4.8. The minimal allocation of subchannels for a segment (if the segment is used) is ~~53~~ subchannels (and shall follow section 8.4.4.5), when STC is used then the encoding of the DL-MAP shall also be performed using the same repetition rate as the FCH (this is done to enable the adequate reception of the FCH and the DL-MAP by Transmit diversity users, as well as regular users) . The first three transmitted subchannels in the first data symbol of the downlink contains the FCH as defined in 8.4.4.2. For segment 0 Subchannels 3-4 are used as the basic allocated Subchannels, for segment 1 Subchannels 14-16, for segment 2 Subchannels 25-27. The DL-MAP shall define the combined STC and regular transmission allocations, regular allocations shall be transmitted from antenna 0 only, while STC allocations shall be transmitted from both antennas (in any case antenna 1 shall always transmit in this combined mode of operation at least the pilot-sets allocated for it) In the following figure the structure of the DL Frame Prefix Subchannel allocation (for the combined operation of STC and regular transmission) is shown:

- page 523 remove figure 231

- page 523 add section 8.4.8.3

### **8.4.8.3 Frequency hopping diversity coding (FHDC)**

#### **8.4.8.3.1 FHDC encoding**

This scheme (as for STC) transmits 2 complex symbols  $s_1$  and  $s_2$ , using the multiple input single output channel (two Tx, one Rx), allocation of subchannels for FHDC transmission shall be even numbered in the same OFDMA symbol, and the first sub-channel shall have an even logical index.

The transmission is based on transmitting the FHDC allocated subchannels from both antennas in the following format:

- First Channel uses: Antenna0 transmits mapped carriers for subchannel X ( $S_1$ ) onto subchannel X and mapped carriers for subchannel X+1 ( $S_2$ ) onto subchannel X+1
- Second Channel uses: Antenna0 transmits ( $-S_2^*$ ) onto subchannel X and ( $S_1^*$ ) onto subchannel X+1

Receiver gets  $r_0$  (reception of subchannel X) and  $r_1$  (reception of subchannel X+1):

$$r_0 = h_{x,0} \cdot S_1 - h_{x,1} \cdot S_2^*$$

$$r_1 = h_{x+1,0} \cdot S_2 + h_{x+1,1} \cdot S_1^*$$

and the user shall extract signals  $S_1, S_2$ .

These estimates benefit from 2nd order diversity as in the 1Tx-2Rx Maximum Ratio Combining scheme.

The downlink preamble will be transmitted for the duration of one OFDMA symbol from both antennas, and subchannels used for FHDC are transmitted in pairs of subchannels in the same OFDMA symbol.

### 8.4.8.3.2 Downlink

The downlink shall enable the co-transmission of regular Subchannel transmission and FHDC Subchannel transmission as explained in 8.4.8. The minimal allocation of subchannels for a segment (if the segment is used) is 5 subchannels (and shall follow section 8.4.4.5), when FHDC is used then the encoding of the DL-MAP shall also be performed using the same repetition rate as the FCH (this is done to enable the adequate reception of the FCH and the DL-MAP by Transmit diversity users, as well as regular users). The DL-MAP shall define the combined FHDC and regular transmission allocations, regular allocations shall be transmitted from antenna 0 only, while STC allocations shall be transmitted from both antennas (in any case antenna 1 shall always transmit in this combined mode of operation at least the pilot-sets allocated for it) Figure 230a shows an example of FHDC usage for OFDMA.

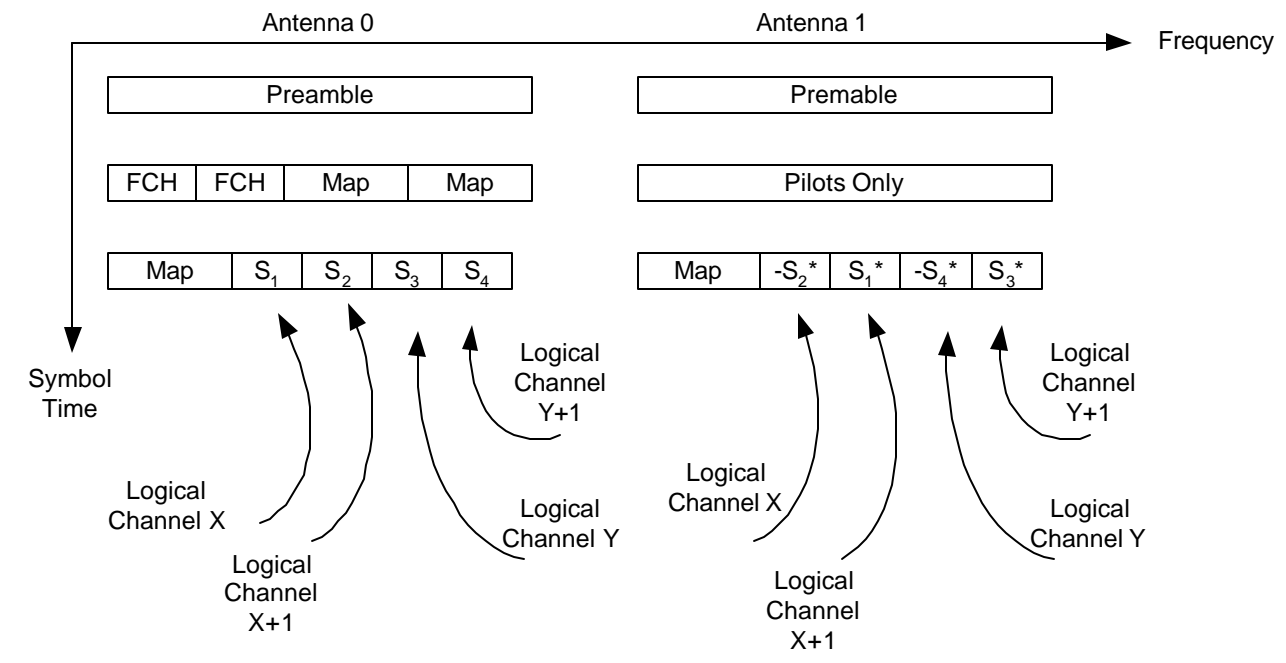

Figure 230a— Example of using FHDC in OFDMA

- page 523 line 47  
change section number 8.4.8.4.1 to 8.4.8.4 and rename it to Downlink Preamble

- page 523 line 50  
For each segment as defined in previous sections, two antennas are used to transmit the transmit diversity STC signal. Therefore from the definition in section 8.4.6.1.1, the following applies:  
Each segment uses 2 types of preamble carrier-sets (one for each antenna) out of the 6 sets in the following



manner:

— Segment 0 - carrier set 0 used by antenna 0, preamble 3 used by antenna 1

— Segment 1- carrier set 1 used by antenna 0, preamble 4 used by antenna 1

— Segment 2- carrier set 2 used by antenna 0, preamble 5 used by antenna 1

The same PN series as defined in that section is also used in the transmit diversity STC mode.

- page 524 line 1

change section number 8.4.8.4.2 to 8.4.8.5 and rename it to Downlink Symbol Structure

- page 524 line 4

The same symbol structure defined in sections 8.4.6.1.1 and 8.4.6.1.2 shall apply for the transmit diversity STC mode.

- page 524 Table 245 rename to : Transmit diversity STC pilot allocation

- page 524 line 26

Subchannels allocated to ~~regular non-STC~~ users shall be transmitted by Antenna 0 only, while Subchannels that are allocated to transmit diversity STC use shall be transmitted from both antennas.

- page 524 line 29

change section number 8.4.8.5 to 8.4.8.6

- page 524 line 34

change section number 8.4.8.6 to 8.4.8.7

and add:

#### **8.4.8.8 Transmission through 4 Antennas (possible enhancement)**

The Transmit diversity schemes could be further enhanced by using 4 antennas at the transmission site. Two antennas are now being used in order to transmit each symbol (the first antenna transmits the signal as defined in 8.4.8.2 and 8.4.8.3, and the second transmits the same signal with a complex vector rotation), this transmission shall create additional multipaths received by the user, these multipaths aim are to reduce the effect of the Rayleigh channel variation. This method gives the space diversity associated with the STC/FHDC with an additional multipath creation caused by another antenna; this scheme is presented in figure 230b:

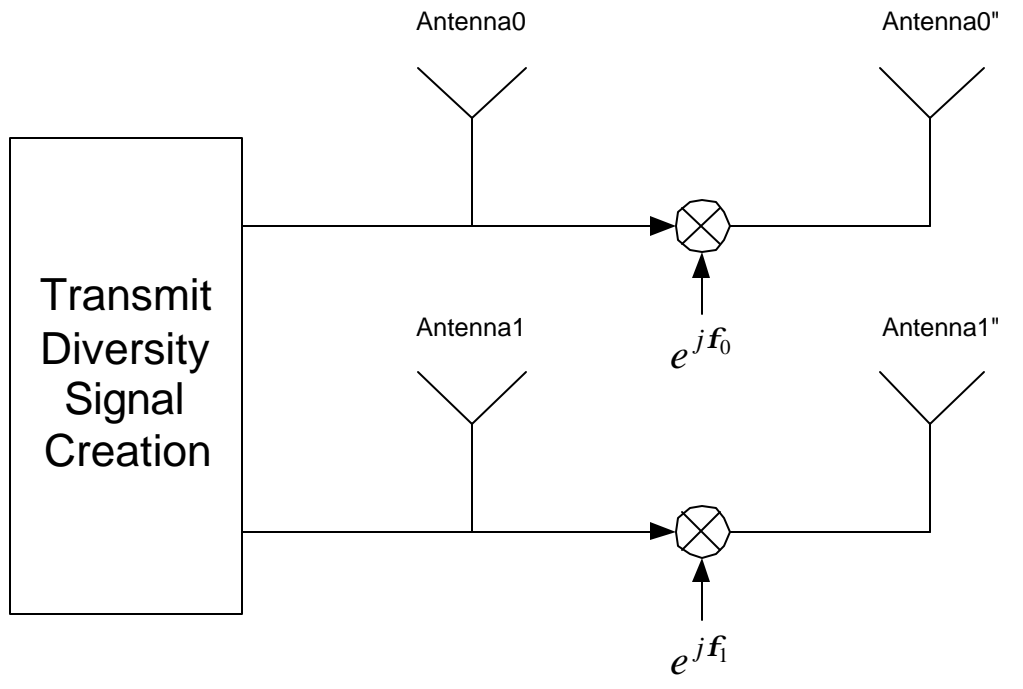

Figure 230b— Illustration of Transmit diversity using 4 antennas

This method does not change the channel estimation process of the user, therefore this scheme could be implemented without any changes made to the Transmit diversity user.

- page 524 line 51 – 8.4.9. Channel Coding

... the process of regular encoding and repetition encoding is shown in figure 232.

When repetition encoding is used in PUSC, concatenation of FEC blocks (section 8.4.9.2) is not allowed.