

Project	IEEE 802.16 Broadband Wireless Access Working Group < http://ieee802.org/16 >	
Title	IEEE 802.16e Handoff Draft	
Date Submitted	2003-03-13	
Source(s)	Itzik Kitroser IEEE802.16e Handoff ad-hoc chair On behalf of IEEE802.16e Handoff ad-hoc group. Runcom Ltd. Hachoma 2 St. 75655 Rishon Lezion, Israel	Voice: +972-3-9528440 Fax: +972-3-9528805 Itzikk@runcom.co.il
Re:	Call for inputs for the Handoff Ad-hoc group	
Abstract	This document is the output of the Handoff ad-hoc group. The document describes a set of messages and parameters for handoff MAC level and PHY independent support for the 802.16e mobile group.	
Purpose	Handoff Ad Hoc draft proposal for the IEEE802.16e group.	
Notice	This document has been prepared to assist IEEE 802.16. It is offered as a basis for discussion and is not binding on the contributing individual(s) or organization(s). The material in this document is subject to change in form and content after further study. The contributor(s) reserve(s) the right to add, amend or withdraw material contained herein.	
Release	The contributor grants a free, irrevocable license to the IEEE to incorporate material contained in this contribution, and any modifications thereof, in the creation of an IEEE Standards publication; to copyright in the IEEE's name any IEEE Standards publication even though it may include portions of this contribution; and at the IEEE's sole discretion to permit others to reproduce in whole or in part the resulting IEEE Standards publication. The contributor also acknowledges and accepts that this contribution may be made public by IEEE 802.16.	
Patent Policy and Procedures	The contributor is familiar with the IEEE 802.16 Patent Policy and Procedures < http://ieee802.org/16/ipr/patents/policy.html >, including the statement "IEEE standards may include the known use of patent(s), including patent applications, provided the IEEE receives assurance from the patent holder or applicant with respect to patents essential for compliance with both mandatory and optional portions of the standard." Early disclosure to the Working Group of patent information that might be relevant to the standard is essential to reduce the possibility for delays in the development process and increase the likelihood that the draft publication will be approved for publication. Please notify the Chair < mailto:chair@wirelessman.org > as early as possible, in written or electronic form, if patented technology (or technology under patent application) might be incorporated into a draft standard being developed within the IEEE 802.16 Working Group. The Chair will disclose this notification via the IEEE 802.16 web site < http://ieee802.org/16/ipr/patents/notices >.	

Handoff mechanism for IEEE 802.16e

1 HO parameters and definitions

1.1 Definitions

Mobile Subscriber Station (MSS) – IEEE 802.16e based SS that supports mobile functionality. [This terms requires its own definition. It is suggested that we revise this definition in a later stage].

Base Station Sector (BS) – Part of an IEEE 802.16e BS, which provides a single instance of the IEEE802.16e air-interface on a single radio frequency channel.

Handoff (HO) – The process in which a MSS migrates from the air-interface provided by one BS to the air-interface provided by another BS. Two HO variants are defined,

- Hard HO - A HO where service with the new BS starts after a disconnection of service with the old BS.
- Soft HO - A HO where service with the new BS starts before disconnection of the service with the old BS.

Serving BS – For any MSS, the serving BS is the BS with which the MSS has recently performed registration at initial network-entry or during an HO.

Target BS – The BS that a MSS intends to be registered with at the end of a HO.

Neighbor BS – For any MSS, a neighbor BS is a BS whose downlink transmission can be demodulated by the MSS.

Scanning Interval – A time period intended for monitoring neighbor BS by the MSS, to determine their suitability as targets for HO.

Monitored BS – A BS that is monitored by the MSS during its scanning interval.

Selected BS – A subset of Monitored BS, which is selected as potential Target BS.

2 Network reference model

2.1 Entities

The network reference model consists of BS units covering a certain area, and connected by a backbone network. Several such networks, owned by different operators may coexist in the same service area. Each backbone network may contain centralized AAA (Authorization, Authentication and Accounting), management, provisioning or other specialized servers. Specifically, those servers responsible for authentication and service authorization are collectively referred to as ASA-server(s) and may be single, multiple, centralized or distributed. The operation of these servers with the BS and MSS is specified to the extent of defining the control messages.

Reference Point	Elements to be Specified by 802.16E
MSS	Mobile Subscriber Station, contains MAC (CS), PHY layers
BS	Base Station Sector: a single MAC entity covers a single sector. BS, at the network side, supports functionality similar to Foreign Agent of Mobile IP working in "foreign agent care-of address" mode.
ASA Server(s)	Authentication and Service Authorization Server servicing the whole operator's network. These servers are optional, and may be implemented as a distributed entity.

Table 1: Mobility Related Entities

Figure 1 shows an example of such a network, where two networks operated by different operators coexist in the same service area. BS #1 is the serving BS for the depicted MSS. BS #2 and BS #3 are neighbor BS. Should the depicted MSS move closer to BS #2, as drawn by dotted line BS #2 might be the target BS for an HO. Should the depicted MSS continue movement into the area covered by BS #3, it might perform HO to that BS.

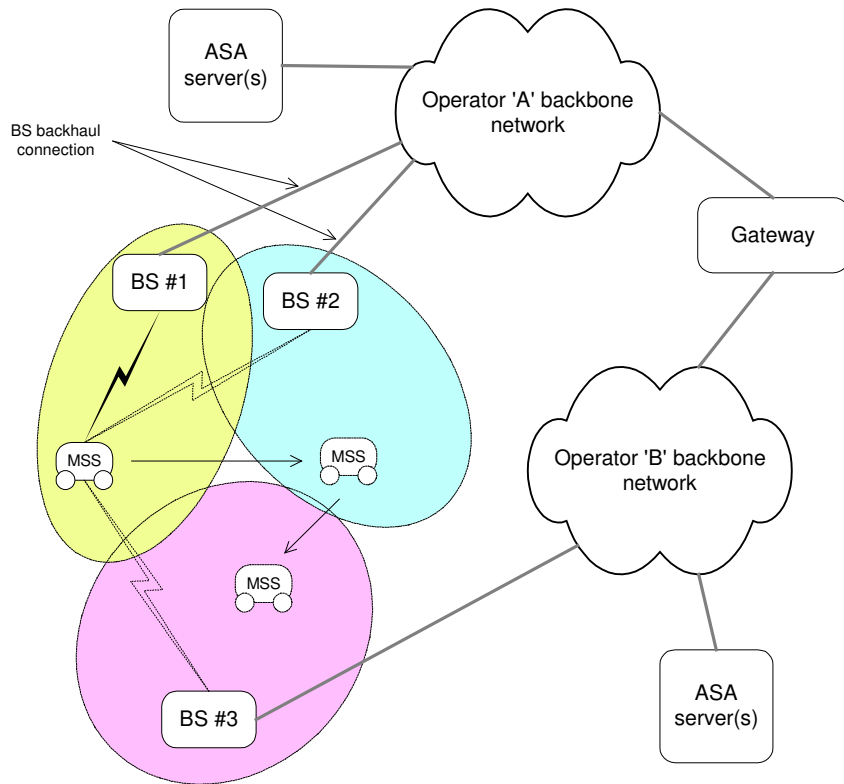

Figure 1: Network model example

Figure 2 shows the network reference model in the data plane.

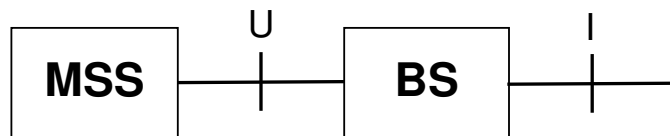

Figure 2: Network reference model, Data Plane

The following reference points are present data plane network model,

Reference Point	Elements to be Specified by 802.16E	Comments
U	PHY, MAC (including CS) operations	
I	None	This point corresponds to data backbone

Table 2: Reference Points at Data Plane

Figure 3 shows the network reference model in the control plane.

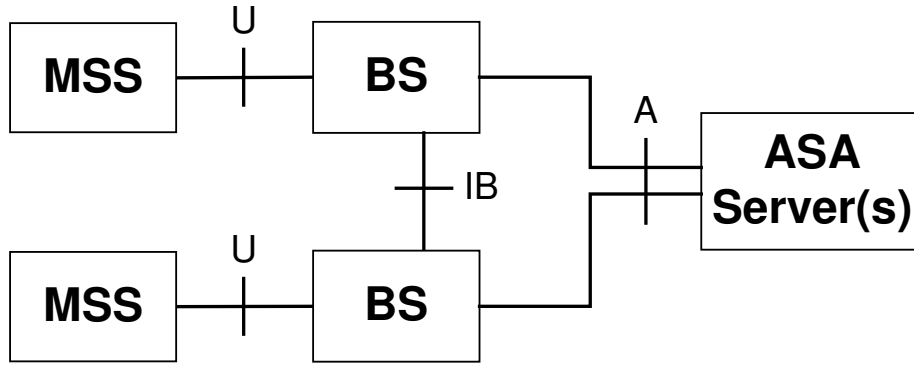

Figure 3: Network reference model, Control Plane

The following reference points are present at the control plane network model

Reference Point	Elements to be Specified by 802.16E	Comments
U	PHY, MAC (including CS) operations, Mobility Sub-layer messages exchange	
IB	BS-to-BS messages	Transport protocol is not specified
A	Messages serving MSS authentication and service authorization functions	Transport protocol is not specified

Table 3: Reference Points at Control Plane

Note: In the case a BS is implemented as a set of BS controlled by a single central controller, IB reference point is located in the controller. This makes inter-cell and intra-cell HO indistinguishable.

2.2 MSS Protocol Stack

No difference here compared to IEEE 802.16a standard.

2.3 BS Protocol Stack

The following picture displays BS protocol stack

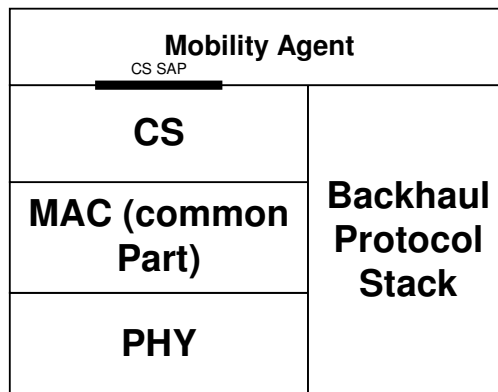

Figure 4: BS Protocol Stack

2.3.1 Mobility Agent (MA) Operations

In addition to regular 802.16 layers, the stack contains Mobility Agent (MA) layer. The functions of MA are similar to functions of Foreign Agent of Mobile IP working in "foreign agent care-of address" mode. Nevertheless, we avoid direct specification of Mobile IP as a protocol that implements mobility features from the backbone side.

MA provides the following functions,

- Termination of tunnel carrying data from MSS home network including de-capsulation of incoming data units
- Communication to CS about:
 - After arrival of new MSS to the cell, creation of new connections. This includes
 - Creation of new classifier(s) to forward data to the connections
 - Specification of proper QoS per connection
 - After MS departure, deletion of connections and classifiers

2.3.2 Primitives for Communication Between CS and MA

2.3.2.1 MA to CS: CS_CREATE_CONNECTION.request/response

Generated to trigger creation of new connection servicing a newly arrived MSS; specifies classifier(s) to forward data to the connections and QoS parameters for the connection

[TBD Parameters]

2.3.2.2 MA to CS: CS_TERMINATE_CONNECTION.request/response

Generated to trigger termination of connection(s) after a MSS leaves the cell

[TBD Parameters]

2.3.2.3 MA to CS: CS_SDU.request

Generated to send an SDU to backbone connection

[TBD Parameters]

2.3.2.4 CS to MA: CS_MSS_ARRIVAL.indication

Signals MSS arrival at the cell

[TBD Parameters]

2.3.2.5 CS to MA: CS_MS_DEPARTURE.indication

Signals MSS departure from the cell

[TBD Parameters]

2.3.2.6 CS to MA: CS_SDU.indication

Generated to signal arrival of an SDU from the backhaul connection

[TBD Parameters]

2.4 MSS Service Context

Network Service is defined as a service provided to the MSS by the network through a single MAC connection with particular connectivity and MAC parameters (including QoS properties). Connectivity properties are defined by specification of MSS network address in its Home Network.

MSS Service Context specifies the set of network services authorized for a given MSS. It is composed of the following elements:

Context Element	Meaning
MSS 48-bit MAC address unique identifier	48-bit unique identifier used by MSS on initial network. This ID does not change while MSS passes from one BS to another. During HO it is used to refer to specific connectivity (addressing) and properties of MAC connections (including QoS properties)
Number N of Network Service IEs	Number of Network Service Information Elements (NSIEs). Each SIE corresponds to a single data connection
N x NSIE	The structure of SIE is specified below
Number M of Security Association	Number M of Security Associations established for the MSS.
M x SAIE	TBD

Table 4: MAC service context

Field	Meaning
Address of MSS at Home Network	IP address of MSS at its Home Network. This address does not change while MSS travels from one BS to another. [?]
MAC Connection Parameters	Connection parameters as specified in [1], section 6.1.1.1.2

Table 5: Service Information Element (SIE) contents

2.5 Transfer of Control Information During HO

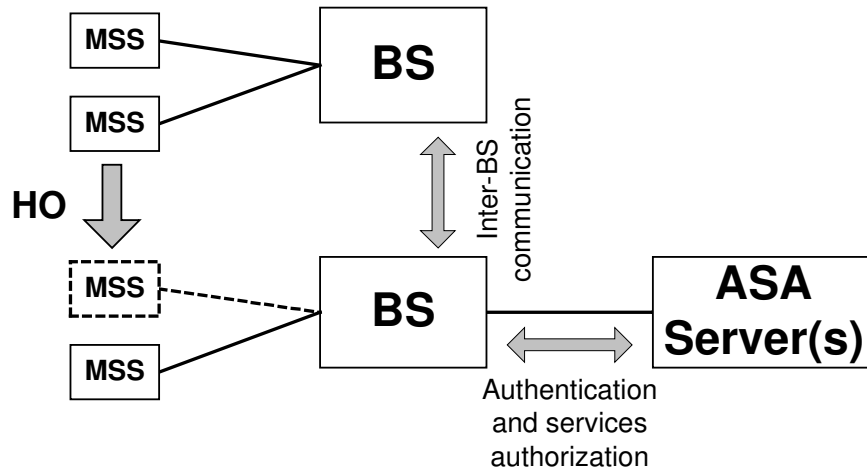

Figure 5: Network Structure (Control Plane) and HO

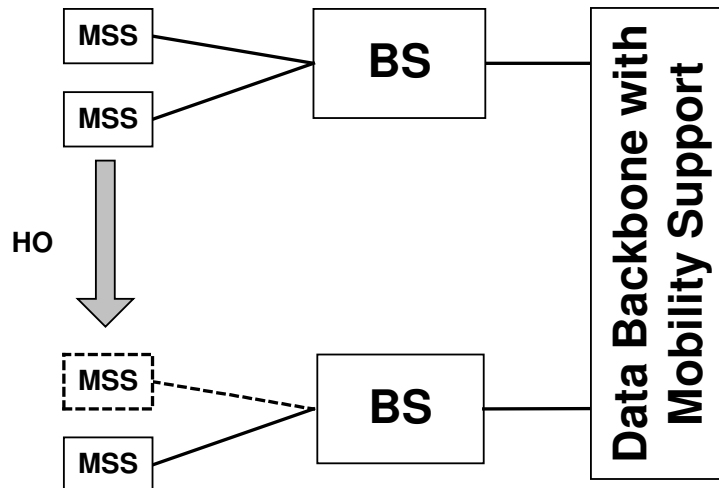

Figure 6: Network Structure (Data Plane) and HO

3 MAC layer HO procedures

This section contains the procedures performed during HO on the air-interface.

3.1 Network topology acquisition

3.1.1 Network topology advertisement

A BS shall broadcast information about the network topology using the NBR-ADV MAC message. MSS may decode this message to find out information about the parameters of neighbor BS. Each MSS will thus be able to synchronize quickly with neighbor BS.

3.1.2 MSS Scanning of neighbor BS

A BS may allocate time intervals to MSS for the purpose of seeking and monitoring neighbor BS suitability as targets for HO. Such a time interval will be referred to as a **scanning interval**.

A MSS may request an allocation of a scanning interval using the SCN-REQ MAC message. The MSS indicates in this message the duration of time it requires for the scan, based on its PHY capabilities.

Upon reception of this message, the BS shall respond with placement of a Scanning_IE in the DL-MAP. The Scanning_IE shall either grant the requesting MSS a scanning interval that is at least as long as requested by that MSS, or deny the request. The BS may also place unsolicited Scanning_IE.

A MSS, upon detection of a Scanning_IE addressed to it in the DL-MAP, shall use the allocated interval to seek for neighbor BS. When neighbor BS are identified, the MSS shall attempt to synchronize with their downlink transmissions, and estimate the quality of the PHY connection.

A MSS may use this interval for UL ranging as well to in a procedure is called **association**. When associating with a neighbor BS, the MSS shall not only synchronize with neighbor BS downlink, but shall also perform two additional stages called **association-initial-ranging** and **association-pre-registration**. Association-initial-ranging is performed by transmitting a RNG-REQ MAC message as specified in [1] section 6.2.9.5 with the extensions specified in section 5.4. Upon reception of a RNG-RSP message with the **prediction of service level** parameter set to 2, the MSS marks the target BS as Associated. Information on Association is reported to the Serving BS. The target BS may store information on newly associated MSS. Association state of specific MSS at the BS shall be aged-out after ASC-AGING-TIMER timeout.

3.2 HO process

The section defines the HO process in which a MSS migrates from the air-interface provided by one BS to the air-interface provided by another BS. The HO process belongs to the break-before-make type and consists of the following stages:

1. HO initiation, the decision to start the process is taken
2. Termination of service with the serving BS, where all connections belonging to the MSS are terminated, and the context associated with them (i.e. information in queues, ARQ state-machine, counters, timers, etc.) is discarded
3. Network re-entry in target BS, where the MSS re-enters the network using a fast network entry procedure. After network re-entry, connection belonging to the MSS are re-established based on the availability of resources in the target BS.

The HO process, and its similarity to the initial network entry process, is depicted in Figure 7.

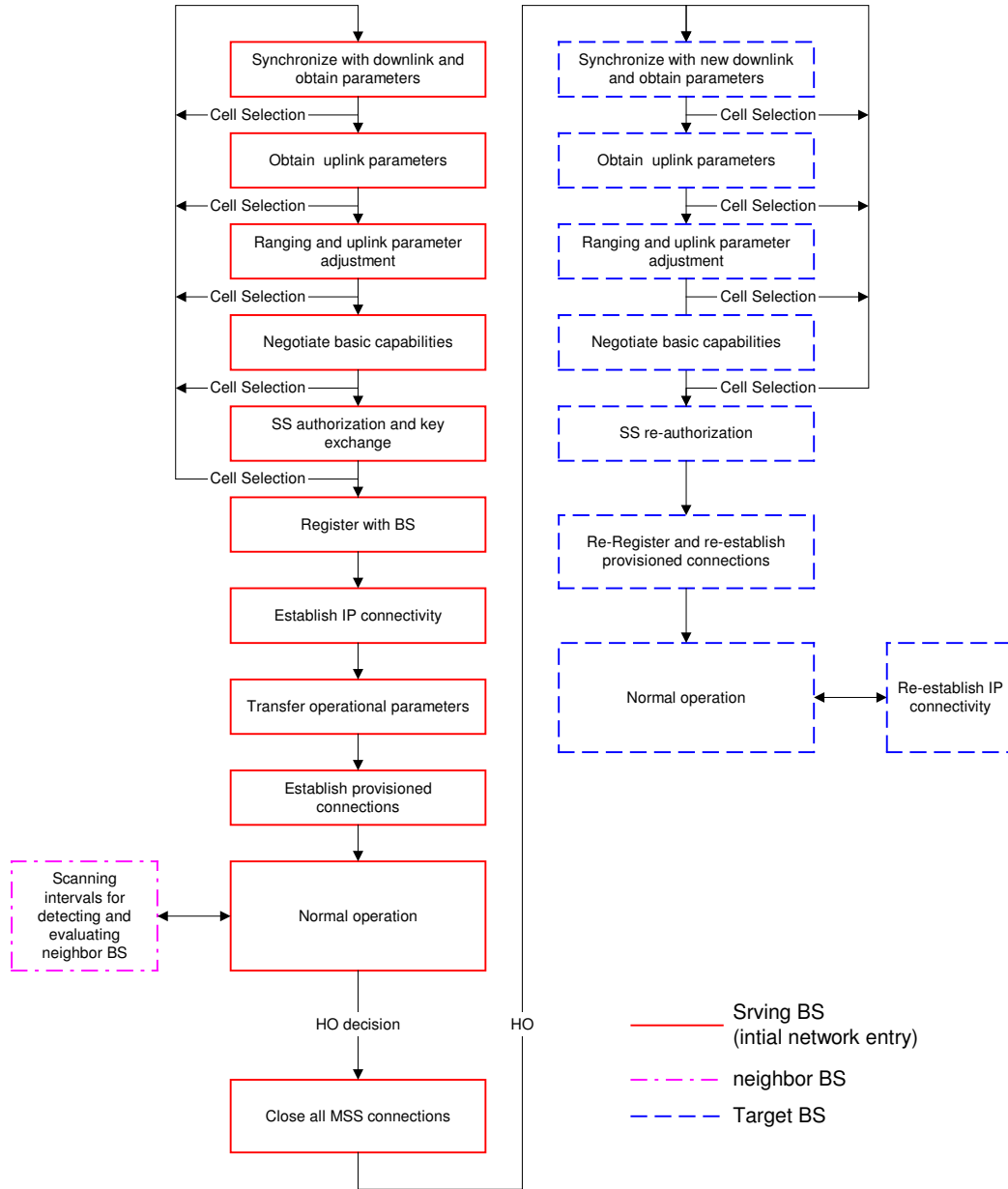

Figure 7: HO and initial network entry

3.2.1 Cell Selection

Cell selection is a terminology used to refer to situations where a MSS leaves a BS before getting to the normal-operation state. Such procedure does not involve termination of existing connections and their re-opening in the target BS. A MSS may perform a cell selection if such an action is necessary with respect to its PHY signal quality. In such a case the MSS shall restart the initial re-entry sequence or the HO sequence as applicable. No action is required from the BS during an cell selection.

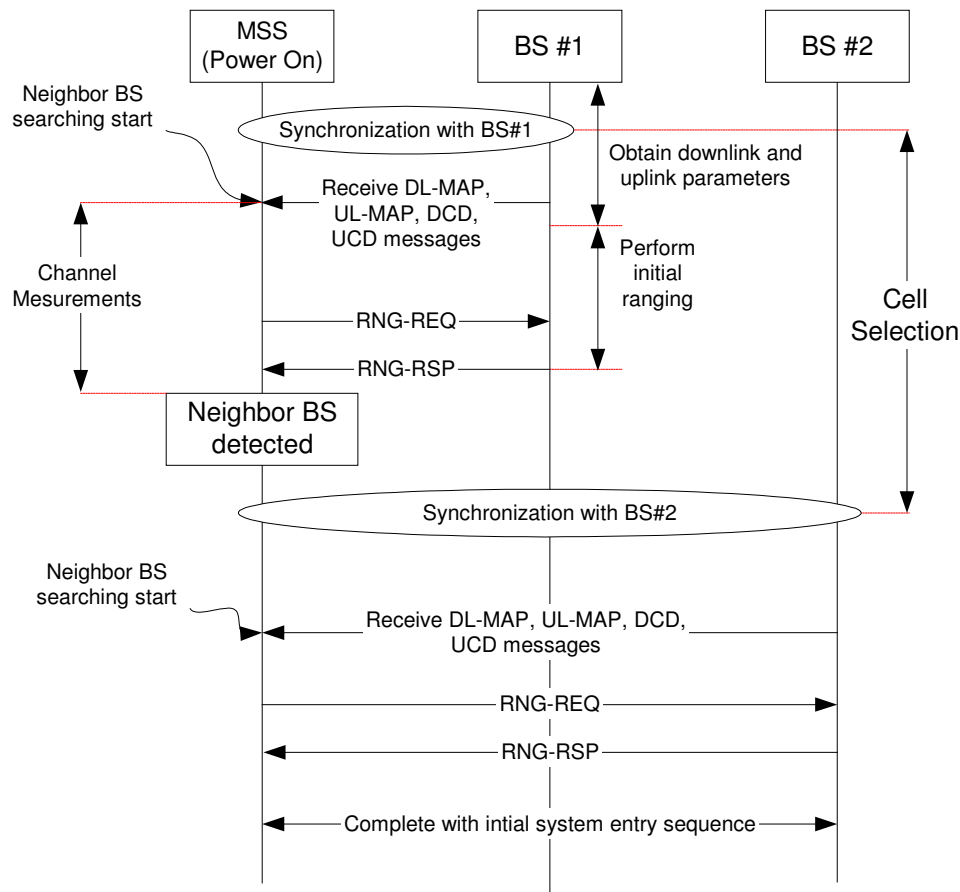

Figure 8: Example of cell selection procedure

3.2.2 HO initiation

Either a MSS or a BS may initiate a HO by transmitting the MSSHO-REQ or BSHO-REQ MAC messages. It is anticipated that in most situations the MSS will be the initiator of the HO, but sometimes a BS may be the initiator of a HO to facilitate load sharing among BS.

When MSSHO-REQ is sent by a MSS, the MSS may indicate possible target BS (from signal quality point of view). When sent by a BS, the BS may indicate the recommended target BS (based on their capability to meet the MSS QoS requirements). The MSSHO-REQ message may include an indication of the estimated time for performing the HO.

At the BS side, before sending BSHO-REQ or after receiving a MSSHO-REQ message, the BS shall notify neighboring BS through the backbone of the HO request. The BS shall further acquire from the neighbor BS information regarding their capability of serving the requesting MSS. See section 5.4 for specification of the communication through the backbone network, and the information exchanged between BS.

After receiving MSSHO-REQ or BSHO-REQ message, the receiving party shall respond with a HO-RSP MAC message. When sent by a BS, the HO-RSP message may indicate a recommended target BS. The MSS, at the risk that if it chooses an alternative target BS, it might receive a degraded level of service, may ignore this recommendation (this includes staying with its serving BS, i.e. skipping the HO). The HO-RSP message may also include an estimation of the time when the HO would take.

3.2.3 Termination with the serving BS

After the [MSS/BS]HO-REQ/HO-RSP handshake is completed, the MSS may begin the actual HO. This is done by sending a HO-IND MAC message.

Upon reception of a HO-IND MAC message, the BS may close all connections and discard MAC state machines and MPDUs associated with the MSS.

4 Drops and corrupted HO attempts

A drop is defined as the situation where a MSS has stopped communication with its serving BS (either in the downlink, or in the uplink) before the normal HO sequence outlined in 3.2.1 and 3.2.3 has been completed.

A MSS can detect a drop by its failure to demodulate the downlink, or by exceeding the RNG-REQ retries limit allowed for the periodic ranging mechanism. A BS can detect a drop by exceeding the RNG-REQ retries limit allowed for the periodic ranging mechanism.

When the MSS has detected a drop, it shall attempt network re-entry with its preferred target BS as outlined in section 4.1.1. When the BS has detected a drop, it shall react as if a HO-IND MAC message has been received from the dropped MSS.

4.1.1 Re-entry with the target BS

When re-entry with the target BS takes place, the target BS as well as all neighbor BS are aware of the HO in progress (except in a drop situation). At re-entry, the MSS performs the steps as shown in Figure 7.

4.1.1.1 Synchronize with downlink and obtain parameters

For MSS that have used their scanning interval to synchronize with target BS and have decoded the NBR-ADV message, this stage should be immediate. In other situations this procedure defaults to the one specified for initial network entry.

4.1.1.2 Obtain uplink parameters

For MSS that have decoded the NBR-ADV message, this stage should be immediate. In other situations this procedure defaults to the one specified for initial network entry.

4.1.1.3 Ranging and uplink parameters adjustment

For MSS that have used their scanning interval to do UL ranging with target BS this stage should be immediate. Otherwise, this stage is similar to the one performed at initial network entry. During this stage the MSS is assigned a new basic and primary management CID in the target BS.

As opposed to initial network entry, where this stage is performed on contention basis, here the ranging opportunity may be allocated individually by the BS based on a MSS 48-bit MAC address identifier. This identifier is forwarded to the target BS via the backbone network (see section 6). This is done using the Fast_UL_ranging_IE() (see 5.9) in the UL-MAP. When an initial ranging opportunity is not allocated individually, this procedure defaults to the one specified for initial network entry.

4.1.1.4 Negotiate basic capabilities

This stage is identical to the one performed during initial network entry.

4.1.1.5 MSS re-authorization

During this stage the MSS performs the re-authorization part of the PKM protocol used at initial network entry (see [1] section 7.2). The BS authenticates the user and as the security context has not changed (it is transferred from the old BS via backbone, see section 6) the security sub-layer can continue in normal operation.

[More details should be provided here]

4.1.1.6 Re-register and re-establish provisioned connections

This stage is equivalent to several stages performed during initial network entry. In this stage the MSS re-registers with the BS, and receives on the registration response a conversion table that maps the connections it had with its previous serving BS to a new set of connections on the current serving BS. In doing so, the MSS skips the **establish-IP-connectivity** stage, where it is assigned an IP address for management purposes. This stage is not really skipped during HO, instead it is postponed until the normal-operation stage is reached. The **transfer-operational-parameters** and the **time-of-day establishment** stage are skipped as none of the information contained in the configuration file, nor the time-of-day is expected to change.

The MSS attempts the re-registration by sending the normal REG-REQ MAC message. At this stage the MSS has already provides its 48-bit MAC address identifier, and the BS can recognize that the MSS is performing a HO. The BS REG-RSP shall therefore include TLV values for re-establishing the provisioned connections (see section 5.10).

4.1.1.7 Commence normal operation

At this stage normal operation commences. The MSS shall re-establish its IP connectivity as specified at initial network entry. **Figure 9** shows how a complete HO process might look like in the time domain.

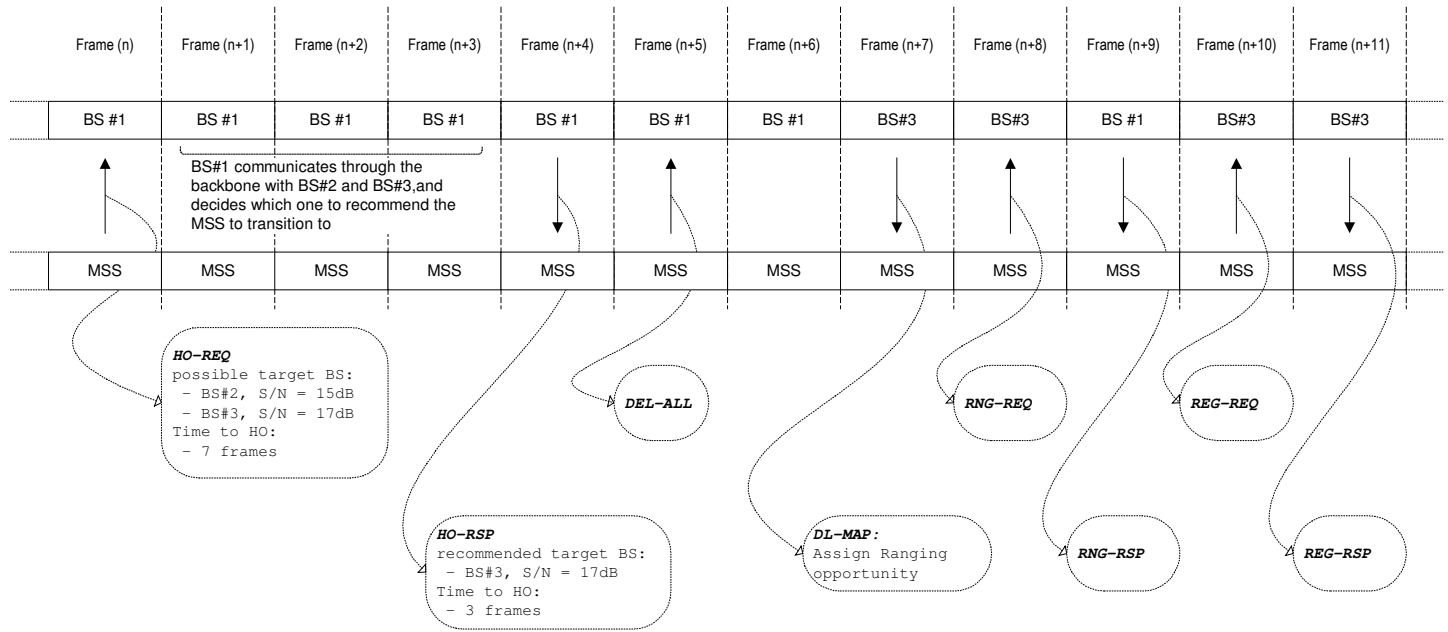

Figure 9: View of a HO process in the time domain

4.1.2 HO completion

[This section should discuss the following:

Post HO operations (mostly applicable if make-before-break HO is supported)

]

5 MAC messages for HO

5.1 Neighbor Advertisement (NBR-ADV) message

An NBR-ADV message shall be broadcasted by a BS at a periodic interval (Table 21) to define the characteristics of neighbor BS. The message parameters following the configuration change count shall be encoded in a TLV format in which the type and length fields are each 1 byte long.

Syntax	Size	Notes
NBR-ADV_Message_Format() {		
Management Message Type = ?	8 bits	
N_NEIGHBORS	8 bits	
For (j=0 ; j<N_NEIGHBORS ; j++) {		
Neighbor BS-ID	48 bits	
Configuration Change Count	8 bits	
Physical Frequency	16 bits	
TLV Encoded Neighbor information	Variable	TLV specific
}		
}		

Table 6: NBR-ADV message format

A BS shall generate NBR-ADV messages in the format shown in Table 6. The following parameters shall be included in the NBR-ADV message,

N_Neighbors – Number of advertised neighbor BS

For each advertised neighbor BS, the following parameters shall be included,

Neighbor BS-ID – Same as the **Base Station ID** parameter in the DL-MAP message of neighbor BS

Configuration Change Count – Incremented by one (modulo 256) whenever any of the values relating to this neighbor BS change. If the value of this count in a subsequent NBR-ADV message remains the same, the MSS can quickly to disregard the TLV encoded information

Physical Frequency – Physical frequency in multiples of 0.1MHz

All other parameters are coded as TLV value (see Table 22).

For each advertised neighbor BS, the following TLV parameters may be included,

DCD_settings – The DCD_settings is a compound TLV value that encapsulates a DCD message that may be transmitted in the advertised BS downlink channel. This information is intended to enable fast synchronization of the MSS with the advertised BS downlink.

UCD_settings – The UCD_settings is a compound TLV value that encapsulates a UCD message that may be transmitted in the advertised BS downlink channel. This information is intended to enable fast synchronization of the MSS with the advertised BS uplink.

5.2 Scanning Interval Allocation Request (SCN-REQ) message

An SCN-REQ message may be transmitted by a MSS to request a scanning interval for the purpose of seeking neighbor BS, and determining their suitability as targets for HO.

Syntax	Size	Notes
SCN-REQ_Message_Format() {		
Management Message Type = ?	8 bits	
Scan Duration	20 bits	For SCa PHY, units are mini-slots. For OFDM/OFDMA PHY, units are OFDM symbols
}		

Table 7: SCN-REQ message format

A MSS shall generate SCN-REQ messages in the format shown in Table 21. The following parameters shall be included in the SCN-REQ message,

Scan Duration – The requested period of time for the scan. The units are PHY-dependent, as specified in Table 7.

5.3 Scanning Information Element

A Scanning_IE shall be placed in the DL-MAP message by a BS in response to an SCN-REQ message sent by a MSS. The Scanning_IE shall be placed in the extend DIUC (extension code = ?) within a DL-MAP IE. A value of zero in the Scan Duration field shall be interpreted as denial of the SCN-REQ. A BS may also send an unsolicited Scanning_IE.

The format of the IE is PHY dependent as shown in Table 8.

For SCa PHY:		
Syntax	Size	Notes
Scanning_IE {		
CID	16 bits	MSS basic CID
Scan Start	22 bits	Offset (in units of mini-slots) to the start of the scanning interval from the mini-slot boundary specified by the downlink Allocation_Start_Time

Scan Duration	22 bits	Duration (in units of mini-slots) where the MSS may scan for neighbor BS.
}		

For OFDM PHY:		
Syntax	Size	Notes
Scanning_IE {		
CID	16 bits	MSS basic CID
Scan Start	18 bits	Indicates the scanning interval start time, in units of OFDM symbol duration, relative to the start of the first symbol of the PHY PDU (including preamble) where the DL-MAP message is transmitted.
Scan Duration	18 bits	Duration (in units of OFDM symbols) where the MSS may scan for neighbor BS.
}		

For OFDMA PHY:		
Syntax	Size	Notes
Scanning_IE {		
CID	16 bits	MSS basic CID
Scan Start	18 bits	The offset of the OFDM symbol in which the scanning interval starts. Measured in OFDM symbols from the time specified by the Allocation_Start_time field in the DL-MAP
Scan Duration	18 bits	Duration (in units of OFDM symbols) where the MSS may scan for neighbor BS.
}		

Table 8: Scanning_IE format

5.4 Ranging Request/Response RNG-REQ/RSP

[This text should be added to section 6.2.2.3.5 in [1]]

A MSS may use the RNG-REQ message in its scanning interval for associating with a neighbor BS. When associating with a neighbor BS, the MSS shall send the RNG-REQ message with the following parameters,

Downlink Channel ID – The identifier of the downlink channel on which the MSS received the UCD describing the uplink on which this ranging request message is to be transmitted. This is an 8-bit field.

SS MAC Address – A 48-bit unique identifier for the MSS.

CID at MAC Header – Shall always be the Initial Ranging CID.

MSS Association Channel ID – An identifier of the downlink channel on which the MSS is currently registered. This is an 8-bit field.

[This text should be added to section 6.2.2.3.6 in [1]]

When a BS sends a RNG-RSP message in response to a RNG-REQ message containing a **MSS Association Channel ID TLV**, The BS may include the following parameter in the RNG-RSP message,

Service Level Prediction – This value indicates the level of service the MSS can expect from this BS. The following encodings apply:

0 = No service possible for this MSS

1 = Service requested (as determined by the 48-bit MSS MAC address) is available

2 = Service request at requested QoS level is available

This is an 8-bit field.

5.5 BS HO Request (BSHO-REQ) message

The BS may transmit a BSHO-REQ message when it wants to initiate an HO. The message shall be transmitted on the basic CID.

Syntax	Size	Notes
BSHO-REQ_Message_Format() {		
Management Message Type = ?	8 bits	
Estimated HO time	8 bits	
N_Recommended	8 bits	
For (j=0 ; j<N_NEIGHBORS ; j++) {		
Neighbor BS-ID	48 bits	
}		
}		

Table 9: BSHO-REQ message format

A BS shall generate BSHO-REQ messages in the format shown in Table 9. The following parameters shall be included in the BSHO-REQ message,

Estimated HO time – Estimated number of frames until the HO will take place. A value of zero in this parameter signifies that this parameter should be ignored.

N_Recommended – Number of recommended neighbor BS

For each recommended neighbor BS, the following parameter shall be included,

Neighbor BS-ID – Same as the **Base Station ID** parameter in the DL-MAP message of neighbor BS

5.6 MSS HO Request (MSSHO-REQ) message

The MSS may transmit an MSSHO-REQ message when it wants to initiate an HO. The message shall be transmitted on the basic CID.

Syntax	Size	Notes
MSSHO-REQ_Message_Format() {		
Management Message Type = ?	8 bits	
Estimated HO time	8 bits	
N_Recommended	8 bits	
For (j=0 ; j<N_NEIGHBORS ; j++) {		
Neighbor BS-ID	48 bits	
BS S/(N+I)	8 bits	
}		
}		

Table 10: MSSHO-REQ message format

A MSS shall generate MSSHO-REQ messages in the format shown in Table 9. The following parameters shall be included in the MSSHO-REQ message,

Estimated HO time – Estimated number of frames until the HO will take place. A value of zero in this parameter signifies that this parameter should be ignored.

N_Recommended – Number of recommended neighbor BS

For each recommended neighbor BS, the following parameters shall be included,

Neighbor BS-ID – Same as the **Base Station ID** parameter in the DL-MAP message of neighbor BS

BS S/(N + I) – This parameter indicates the signal to noise and interference ratio measured by the MSS from the particular BS. The value shall be interpreted as an unsigned byte with units of 0.25dB.

5.7 HO Response (HO-RSP) message

Either a MSS or a BS shall transmit an HO-RSP message upon reception of HO-REQ message. The message shall be transmitted on the basic CID.

Syntax	Size	Notes
HO-RSP_Message_Format() {		
Management Message Type = ?	8 bits	
Estimated HO time	8 bits	
N_Recommended	8 bits	
For (j=0 ; j<N_NEIGHBORS ; j++) {		
Neighbor BS-ID	48 bits	
BS rating	8 bits	This parameter exists only when the message is sent by the BS
}		
}		

Table 11: HO-RSP message format

A BS or MSS shall generate HO-RSP messages in the format shown in Table 11. The following parameters shall be included in the HO-RSP message,

Estimated HO time – Estimated number of frames until the HO will take place. A value of zero in this parameter signifies that this parameter should be ignored.

N_Recommended – Number of recommended neighbor BS

For each recommended neighbor BS, the following parameters shall be included,

Neighbor BS-ID – Same as the **Base Station ID** parameter in the DL-MAP message of neighbor BS

BS rating – This parameter exists only when the BS sends the HO-RSP message. The parameter indicates the relative level to which the target BS could meet the MSS QoS requirements. A value of zero in this parameter signifies that this parameter should be ignored.

5.8 HO Indication (HO-IND) message

A MSS shall transmit a HO-IND message for final indication that it is about to perform a HO. The message shall be transmitted on the basic CID.

Syntax	Size	Notes
HO_IND_Message_Format() {		
Management Message Type = ?	8 bits	
TLV Encoded Information	Variable	TLV specific
}		

Table 12: HO-IND message format

A MSS shall generate HO-IND messages in the format shown in Table 12. If Privacy is enabled, the HO-IND message shall include the following TLV value,

HMAC Tuple (see 11.4.10 in IEEE 802.16-2001) – The HMAC Tuple Attribute contains a keyed Message digest (to authenticate the sender).

5.9 Fast ranging (Paging) Information Element

A Fast_UL_ranging_IE may be placed in the UL-MAP message by a BS to provide a non-contention based initial-ranging opportunity. The Fast_UL_ranging_IE shall be placed in the extend UIUC (extension code = ?) within a UL-MAP IE. The format of the IE is PHY dependent as shown in Table 13.

For SCa PHY:		
Syntax	Size	Notes
Fast_UL_ranging_IE {		
MAC address	48 bits	MSS MAC address as provided on the RNG_REQ message on initial system entry
UIUC	4 bits	UIUC \neq 15. A four-bit code used to define the type of uplink access and the burst type associated with that access.
Offset	12 bits	Indicates the start time, in units of minislots, of the burst relative to the Allocation Start Time given in the UL-MAP message. The time instants indicated by offsets are the transmission times of the first symbol of the burst including preamble.
Reserved	4 bits	
}		

For OFDM PHY:		
Syntax	Size	Notes
Fast_UL_ranging_IE {		
MAC address	48 bits	MSS MAC address as provided on the RNG_REQ message on initial system entry
UIUC	4 bits	UIUC \neq 15. UIUC \neq 4. A four-bit code used to define the type of uplink access and the burst type associated with that access.
Duration	12 bits	The Duration indicates the length, in units of OFDM symbols, of the allocation. The start time of the first allocation shall be the Allocation Start Time given in the UL-MAP message.
Reserved	4 bits	
}		

For OFDMA PHY:		
Syntax	Size	Notes
Fast_UL_ranging_IE {		
MAC address	48 bits	MSS MAC address as provided on the RNG_REQ message on initial system entry
UIUC	4 bits	UIUC \neq 15. A four-bit code used to define the type of uplink access and the burst type associated with that access.

OFDM Symbol offset	10 bits	The offset of the OFDM symbol in which the burst starts, the offset value is defined in units of OFDM symbols and is relevant to the Allocation Start Time field given in the UL-MAP message.
Subchannel offset	6 bits	The lowest index OFDMA subchannel used for carrying the burst, starting from subchannel 0.
No. OFDM Symbols	10 bits	The number of OFDM symbols that are used to carry the UL Burst
No. Subchannels	6 bits	The number OFDMA subchannels with subsequent indexes, used to carry the burst.
Reserved	4 bits	
CID	16 bits	MSS basic CID
}		

Table 13: Fast_UL_ranging_IE format

5.10 REG-RSP TLVs for connection re-establishment

[Add this text to the REG-RSP text in the base standard]

The following TLVs shall be included in the REG-RSP for MSS recognized by the BS through their 48-bit MAC address (provided in the RNG-REQ message) as MSS that are performing HO,

CID_updtae – The CID_update is a TLV value that provides a shorthand method for renewing a connection used in the previous serving BS. The TLV specifies a CID in the new serving BS that shall replace a CID used in the previous serving BS. All the service flows and parameters associated with the old CID remain unchanged. (See Table 23).

Connection_Info – The Connection_Info is a compound TLV value that encapsulates the **Service Flow Parameters** and the **CS Parameter Encodings** TLVs allowed on the DSA-RSP. This TLV enables the new serving BS to renew a connection used in the previous serving BS, but with different QoS settings.

6 Backbone network HO procedures

[This section should contain the procedures performed on backbone to support HO such that BS from different manufacturers are interoperable. The section should address issues such as,

- Centralized HO controller and/or distributed decision
- The information that should be exchanged (Post-HO, Pre-HO and during HO)
- Information exchange model (publishing, on request, combined)
- The transport protocol to use
- Formal definition of the messages

]

6.1 Backbone network services

The backbone network provides a backhaul transmission path to the BS, and may provide other services at the control plane level. Table 14 shows a list of services provided to the BS through backbone network. Some of these services may be provided by other means (highlighted).

Service	Possible methods for providing service	Comments
Backhaul for traffic	-	Transport protocol is not specified
Provide a BS with the identity of its neighbors	<ol style="list-style-type: none"> 1. Get info from ASA server 2. Configuration (network management) 	Options (1) and (2) are really the same, the only difference is where the configuration is done

Provide a BS with the identity of the ASA server	1. ASA server publishes its presence 2. Configuration (network management)	Message format and transport protocol need to be specified for interoperability
Advertise the fact that a certain MSS has registered with a certain BS	1. BS notifies ASA server 2. BS notifies neighbor BS	Message format and transport protocol need to be specified for interoperability
Provide a BS information about a certain MSS	1. ASA server provides information 2. Serving BS provides information (or network management if serving BS cannot be found)	Message format and transport protocol need to be specified for interoperability
Information exchange during HO	1. ASA server is in the middle 2. BS to BS direct exchange	Message format and transport protocol need to be specified for interoperability

Table 14: Backbone network services

As evident from Table 14, it is possible to exchange information between BS directly or through the ASA server. In that respect the protocol used for information exchange on the backbone can regard the ASA server as another BS, and therefore no special message will be required with regards to the ASA server.

6.2 Backbone network communication primitives

The primitives described in this section may be used for communication with peer BS or with an ASA server through the backbone.

6.2.1 I-am-host-of message

This message is sent by a BS to notify other BS (or the ASA server) that a certain MSS is registered with it. The message shall be sent upon MSS registration, and periodically (TBD period). The message might trigger a neighbor BS to request more information on the MSS (either directly from the sender BS, or from the ASA server). The message contains the following information,

Field	Size	Notes
Message Type = ?	8-bit	
Sender BS-ID	48-bit	Base station unique identifier (Same number as that broadcasted on the DL-MAP message)
Target BS-ID	48-bit	Base station unique identifier (Same number as that broadcasted on the DL-MAP message)
Time Stamp	32-bit	Number of milliseconds since midnight GMT (set to 0xffffffff to ignore)
Num Records	16-bit	Number of MSS identity records
For (j=0; j<Num Records; j++) {		
MSS unique identifier	48-bit	48-bit unique identifier used by MSS on initial network entry
}		
Security field	TBD	A means to authenticate this message
CRC field	32-bit	IEEE CRC-32

Table 15: I-am-host-of message

6.2.2 MSS-info-request message

This message may be sent from one BS to another (or to the ASA server) to request information about a MSS. Typically the message will be sent as a reaction to reception of an *I-am-host-of* message, or in cases where a MSS is trying to re-enter the network after a HO. The message contains the following information,

Field	Size	Notes
Message Type = ?	8-bit	
Sender BS-ID	48-bit	Base station unique identifier (Same number as that broadcasted on the DL-MAP message)

Target BS-ID	48-bit	Base station unique identifier (Same number as that broadcasted on the DL-MAP message)
Time Stamp	32-bit	Number of milliseconds since midnight GMT (set to 0xffffffff to ignore)
Num Records	16-bit	Number of SS identity records
For (j=0; j<Num Records; j++) {		
MSS unique identifier	48-bit	48-bit unique identifier used by MSS (as provided by the MSS or by the <i>I-am-host-of</i> message)
}		
Security field	TBD	A means to authenticate this message
CRC field	32-bit	IEEE CRC-32

Table 16: MSS-info-request message

6.2.3 MSS-info-response message

This message may be sent from one BS to another (or from the ASA server) to provide information about a MSS. Typically the message will be sent in response to a *MSS-info-request* message. The message contains the following information,

Field	Size	Notes
Message Type = ?	8-bit	
Sender BS-ID	48-bit	Base station unique identifier (Same number as that broadcasted on the DL-MAP message)
Target BS-ID	48-bit	Base station unique identifier (Same number as that broadcasted on the DL-MAP message)
Time Stamp	32-bit	Number of milliseconds since midnight GMT (set to 0xffffffff to ignore)
Num Records	16-bit	Number of SS identity records
For (j=0; j<Num Records; j++) {		
MSS unique identifier	48-bit	48-bit unique identifier used by MSS (as provided by the MSS or by the <i>I-am-host-of</i> message)
N_NSIE		Number of Network Service Information Elements
For (k=0; k<N_NSIE; k++) {		
Field Size	16-bit	Size of TLV encoded information field below
TLV encoded information	Variable	TLV information as allowed on a DSA-REQ MAC message
}		
N_SAIE		Number of Security Association Information Elements
For (k=0; k<N_SAIE; k++) {		
Field Size	16-bit	Size of TLV encoded information field below
TLV encoded information	Variable	TLV information as allowed on a PKM-xxx MAC messages
}		
Field Size	16-bit	Size of TLV encoded information field below
TLV encoded information	Variable	TLV information as allowed on a SBC-REQ MAC message
}		
Security field	TBD	A means to authenticate this message
CRC field	32-bit	IEEE CRC-32

Table 17: MSS-info-response message

6.2.4 HO-notification message

This message is sent by a BS to advertise a MSS intention to perform HO. The message is typically sent to all neighbor BS. The message serves to alert the neighbor BS that a HO event is going to happen. The message contains the following information,

Field	Size	Notes
-------	------	-------

Message Type = ?	8-bit	
Sender BS-ID	48-bit	Base station unique identifier (Same number as that broadcasted on the DL-MAP message)
Target BS-ID	48-bit	Base station unique identifier (Same number as that broadcasted on the DL-MAP message)
Time Stamp	32-bit	Number of milliseconds since midnight GMT (set to 0xffffffff to ignore)
Num Records	16-bit	Number of MSS identity records
For (j=0; j<Num Records; j++) {		
MSS unique identifier	48-bit	48-bit unique identifier used by MSS (as provided by the MSS or by the <i>I-am-host-of</i> message)
Estimated Time to HO	16-bit	In milliseconds, relative to the time stamp, value 0 of this parameter indicates that no actual HO is pending
}		
Security field	TBD	A means to authenticate this message
CRC field	32-bit	IEEE CRC-32

Table 18: HO-notification message

6.2.5 HO-notification-response message

This message is sent from one BS to another BS, typically in response to a *HO-notification* message. The message serves to provide the BS that sent the *HO-notification* message with information about the level of service the MSS could expect if it transitions to this BS. The message contains the following information,

Field	Size	Notes
Message Type = ?	8-bit	
Sender BS-ID	48-bit	Base station unique identifier (Same number as that broadcasted on the DL-MAP message)
Target BS-ID	48-bit	Base station unique identifier (Same number as that broadcasted on the DL-MAP message)
Time Stamp	32-bit	Number of milliseconds since midnight GMT (set to 0xffffffff to ignore)
Num Records	16-bit	Number of MSS identity records
For (j=0; j<Num Records; j++) {		
MSS unique identifier	48-bit	48-bit unique identifier used by MSS (as provided by the MSS or by the <i>I-am-host-of</i> message)
QoS Estimate	8-bit	TBD
}		
Security field	TBD	A means to authenticate this message
CRC field	32-bit	IEEE CRC-32

Table 19: HO-notification message

6.2.6 Association-notification message

This message is sent from one BS to another BS, to report an association of a MSS. The message contains the following information,

Field	Size	Notes
Message Type = ?	8-bit	
Sender BS-ID	48-bit	Base station unique identifier (Same number as that broadcasted on the DL-MAP message)
Target BS-ID	48-bit	Base station unique identifier (Same number as that broadcasted on the DL-MAP message)

Time Stamp	32-bit	Number of milliseconds since midnight GMT (set to 0xffffffff to ignore)
Num Records	16-bit	Number of MSS identity records
For (j=0; j<Num Records; j++) {		
MSS unique identifier	48-bit	48-bit universal MAC address of the MSS (as provided to the BS on the RNG-REQ message)
}		
Security field	TBD	A means to authenticate this message
CRC field	32-bit	IEEE CRC-32

Table 20: Association-notification message

6.3 Backbone network communication protocol

TBD

7 Convergence sub-layer HO procedures

7.1 Supported convergence sub-layers

[This section should discuss the types of convergence sub-layer that are supported (i.e. IPv4, IPv6, Ethernet, or others)]

7.2 SAP for higher layer protocols

This section defines the services between the MAC and higher layers for supporting the HO process. In some scenarios the higher layers may use information provided by the MAC layer HO process to optimize their HO process and reduce the overall HO duration. The information is defined as set of messages sent by the MAC layer to the higher layers, providing indication of particular events before and after MAC layer HO.

7.2.1 MSS Movement

Occurs at the MSS, indication that the MSS has registered to a new Target BS.

7.2.2 Serving BS Pre-HO

Occurs at the Serving BS, indication that a MAC layer HO of a certain MSS is about to take place.

7.2.3 Target BS Pre-Ho

Occurs at the Target BS, indication that a MAC layer HO of a certain MSS is about to take place.

7.2.4 BS Post-HO

Occurs at the Target BS or MSS, indication that a MAC layer HO between the MSS and the Target BS has been completed.

7.2.5 Serving BS-Link Loss

Occurs at the Serving BS, indication that MAC layer link between the Serving BS and a certain MSS has been lost.

8 Setup and negotiations

[This section should discuss the following:

- Setup and negotiation procedures related to the HO
- PHY dependent parameters and associated handshake
- The model for coexistence of fixed and mobile-SS on the same air-interface instance

]

9 Parameters and constants

System	Name	Time reference	Minimum value	Default value	Maximum value
BS	NBR-ADV interval	Nominal time between transmission of NBR-ADV messages			1s
BS	ASC-AGING-TIMER	Nominal time for aging of MSS associations	0.1s		

Table 21: Parameters and Constants

Name	Type (1 byte)	Length (1 byte)	Value (Variable-length)
DCD_settings	?	Variable	The DCD_settings is a compound TLV that encapsulates an entire DCD message (excluding the generic MAC header). All the rules and settings that apply to the DCD message apply to the contents encapsulated in this TLV.
UCD_settings	?	Variable	The UCD_settings is a compound TLV value that encapsulates an entire UCD message (excluding the generic MAC header). All the rules and settings that apply to the UCD message apply to the contents encapsulated in this TLV.

Table 22: NBR-ADV encodings

Name	Type (1 byte)	Length (1 byte)	Value (Variable-length)
CID_update	?	16-bits	CID in the previous serving BS
		16-bits	Replacement CID in the current serving BS
Connection_Info	?	Variable	The Connection_Info is a compound TLV value that encapsulates the Service Flow Parameters and the CS Parameter Encodings TLVs allowed on the DSA-RSP message. All the rules and settings that apply to the TLVs when used in the DSA-RSP message apply to the contents encapsulated in this TLV.

Table 23: REG-RSP encodings

10 References

- [1] IEEE Std 802.16-2001 "Part 16: Air Interface for Fixed Broadband Wireless Access Systems"
- [2] IEEE P802.16a/D7-2002 "Part 16: Air Interface for Fixed Broadband Wireless Access Systems – Medium Access Control Modifications and Additional Physical Layer Specifications for 2-11 GHz"
- [3] K. Malki et al. "Low latency Handoffs in Mobile IPv4" Jul 2002