

Project	<b>IEEE 802.16 Broadband Wireless Access Working Group</b> < <a href="http://ieee802.org/16">http://ieee802.org/16</a> >	
Title	<b>Improved Data and Pilot Allocation for Cellular OFDMA Systems with Multiple Antennas</b>	
Date Submitted	<b>2004-07-08</b>	
Source(s)	<p>Wonil Roh, JeongTae Oh, Chan-Byoung Chae, Kyunbyoung Ko, Hongsil Jeong, Sung-Ryul Yun, Seungjoo Maeng, Panyuh Joo, Jaeho Jeon, Jaeyeol Kim, Soonyoung Yoon</p> <p><b>Samsung Electronics Co., Ltd.</b></p> <p>Wen Tong, Peiying Zhu, Jianglei Ma, Ming Jia</p> <p><b>Nortel Networks</b></p> <p>Erik Lindskog, Brett Schein, Kamlesh Rath, K. Giridhar, Aditya Agrawal, David Garrett, B. Sundar Rajan, A. Paulraj</p> <p><b>Beceem Communications, Inc.</b></p>	<p><a href="mailto:wonil.roh@samsung.com">wonil.roh@samsung.com</a></p> <p>Voice: +82-31-279-3868</p> <p><a href="mailto:wentong@nortelnetworks.com">wentong@nortelnetworks.com</a></p> <p>Voice: +1-613-763-1315</p> <p><a href="mailto:elindskog@beceem.com">elindskog@beceem.com</a></p> <p>Voice: +1-408-387-5014</p>
Re:	Contribution supporting TGe WG ballot #14b	
Abstract	Improved Data and Pilot Allocation for Cellular OFDMA Systems with Multiple Antennas	
Purpose	Adoption of proposed changes into P802.16e	
	<del>Crossed out indicates deleted text</del> , <u>underlined blue indicates new text change to the Standard</u> , and <u>underlined green indicates newly added text from the original contribution</u>	
Notice	This document has been prepared to assist IEEE 802.16. It is offered as a basis for discussion and is not binding on the contributing individual(s) or organization(s). The material in this document is subject to change in form and content after further study. The contributor(s) reserve(s) the right to add, amend or withdraw material contained herein.	
Release	The contributor grants a free, irrevocable license to the IEEE to incorporate material contained in this contribution, and any modifications thereof, in the creation of an IEEE Standards publication; to copyright in the IEEE's name any IEEE Standards publication even though it may include portions of this contribution; and at the IEEE's sole discretion to permit others to reproduce in whole or in part the resulting IEEE Standards publication. The contributor also acknowledges and accepts that this contribution may be made public by IEEE 802.16.	
Patent Policy and Procedures	<p>The contributor is familiar with the IEEE 802.16 Patent Policy and Procedures (Version 1.0) &lt;<a href="http://ieee802.org/16/ipr/patents/policy.html">http://ieee802.org/16/ipr/patents/policy.html</a>&gt;, including the statement "IEEE standards may include the known use of patent(s), including patent applications, if there is technical justification in the opinion of the standards-developing committee and provided the IEEE receives assurance from the patent holder that it will license applicants under reasonable terms and conditions for the purpose of implementing the standard."</p> <p>Early disclosure to the Working Group of patent information that might be relevant to the standard is essential to reduce the possibility for delays in the development process and increase the likelihood that the draft publication will be approved for publication. Please notify the Chair &lt;<a href="mailto:r.b.marks@ieee.org">mailto:r.b.marks@ieee.org</a>&gt; as early as possible, in written or electronic form, of any patents (granted or under application) that may cover technology that is under</p>	

---

consideration by or has been approved by IEEE 802.16. The Chair will disclose this notification via the IEEE 802.16 web site <<http://ieee802.org/16/ipr/patents/notices>>.

---

# Improved Data and Pilot Allocation for Cellular OFDMA Systems with Multiple Antennas

Wonil Roh, JeongTae Oh, Chan-Byoung Chae, Kyunbyoung Ko, Hongsil Jeong,  
Sung-Ryul Yun, Seungjoo Maeng, Panyuh Joo, Jaeho Jeon, Jaeyeol Kim, Soonyoung Yoon

**Samsung Electronics**

Wen Tong, Peiyong Zhu, Jianglei Ma, Ming Jia

**Nortel Networks**

Erik Lindskog, K. Giridhar, Aditya Agrawal, David Garrett, B. Sundar Rajan, A. Paulraj

**Beceem Communications, Inc.**

## 1. Introduction

~~Current draft standard [1] lacks the efficient methods for data and pilot allocation for OFDMA systems with multiple antennas in the sense that space time coding (STC) operates on the mapped subchannels rather than modulated symbols. When transmit diversity schemes are employed for subchannels that are rather long in time, the channel estimation at the receiver performs poorly. Furthermore, there could be potentially a long latency to decode at the receiver. Furthermore, data and pilot mapping for multiple antennas are not defined for UL in the optional permutation zones.~~

~~In this contribution, STC enhancements with multiple antennas at BS and SS for optional zones for downlink and uplink for OFDMA PHY are proposed. Pilots and data allocation methods are described and the transmission schemes for 2 and 4 antenna BS are also suggested for the downlink and the uplink.~~

Current draft standard [1] provides MIMO operation for two optional permutation zones, FUSC and AMC, in the downlink, but lacks STC features for UL in the optional permutation zones, i.e., optional PUSC and AMC subchannels. In this contribution, STC enhancements for the optional zones in the uplink for OFDMA PHY are proposed, where pilots and data allocation methods are described and are justified by simulation results. In addition, some clarification is made for STC operation in general, and an effort to clarify data allocation for the downlink is made.

## 2. Data and Pilot Allocation

### 2.1. Optional FUSC and AMC for Downlink

*[Replace the section 8.4.8.3 in page 96 of [1] as follows]*

#### 8.4.8.3 STC for the optional zones in the downlink

Two optional zones for the downlink, the optional FUSC and the optional AMC zones, are described in 8.4.6.1.2.3 and 8.4.6.3 [2], respectively. STC may be used to improve system performance for these zones and an example of transmit diversity (TD) with 2 tx and 1 rx is shown in Figure aaa. Subcarrier mapping block in the figure denotes data truncation, if needed, pilot insertion and IFFT input packing.

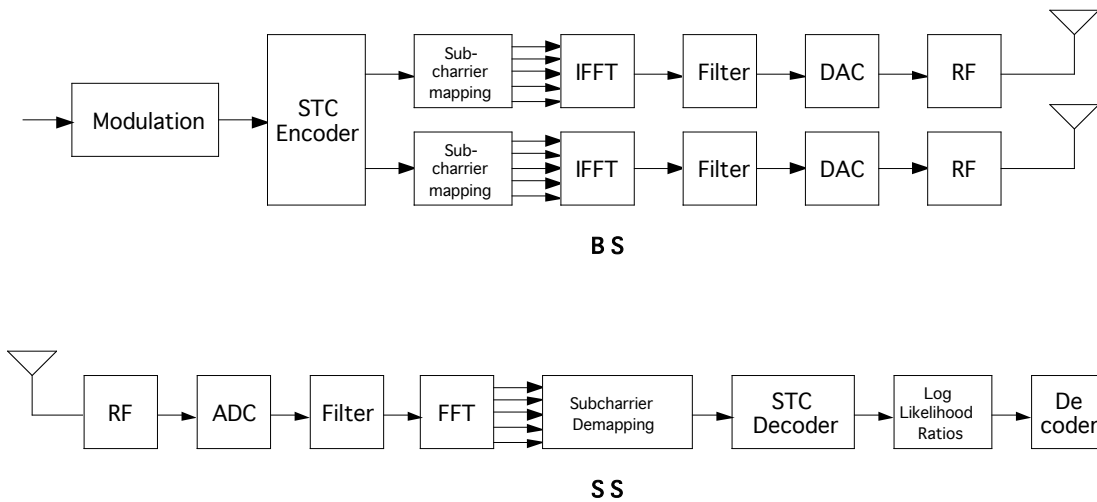

[Figure aaa - Illustration of STC for optional zones in DL](#)

**8.4.8.3.1 Allocation of pilot subcarriers**

[For 2-antenna BS, all pilots in the even symbols shall be allocated for antenna 0 whereas all pilots in the odd symbols shall be allocated for antenna 1. The positions of pilots in the odd symbols are further switched with those of data subcarriers whose locations coincide with pilots in the previous symbol. This is shown in Figure bbb.](#)

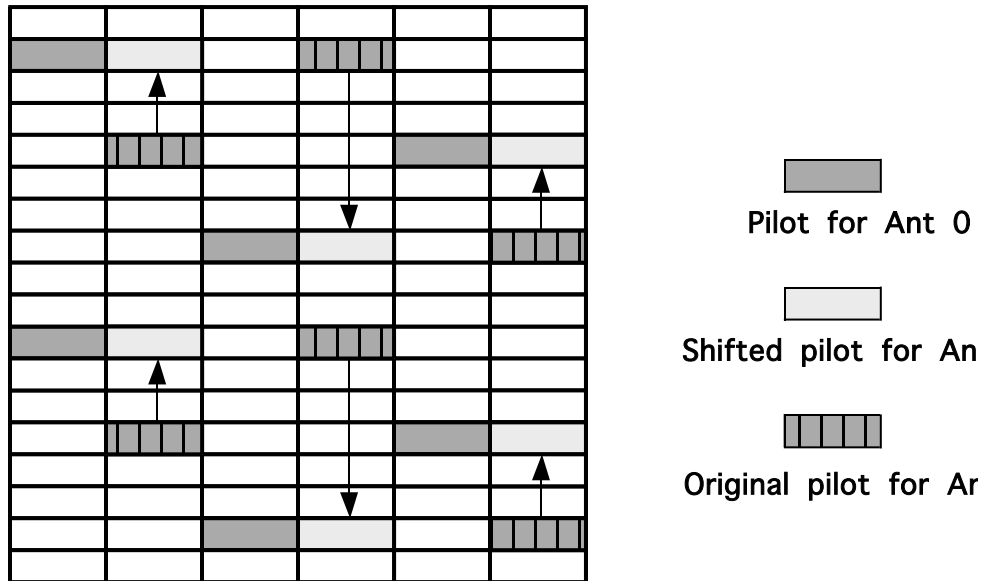

[Figure bbb - Pilot allocation for 2-antenna BS for the optional FUSC and the optional AMC zones](#)

[For 4-antenna BS with more than 2 antennas, pilot pattern shall first be changed as in the 2-antenna BS case, and then the neighboring two subcarriers shall be further punctured-allocated to pilots for other antennas, 2 and 3 as is shown in Figure ccc shows the pilot allocation scheme for 4-antenna BS.](#)

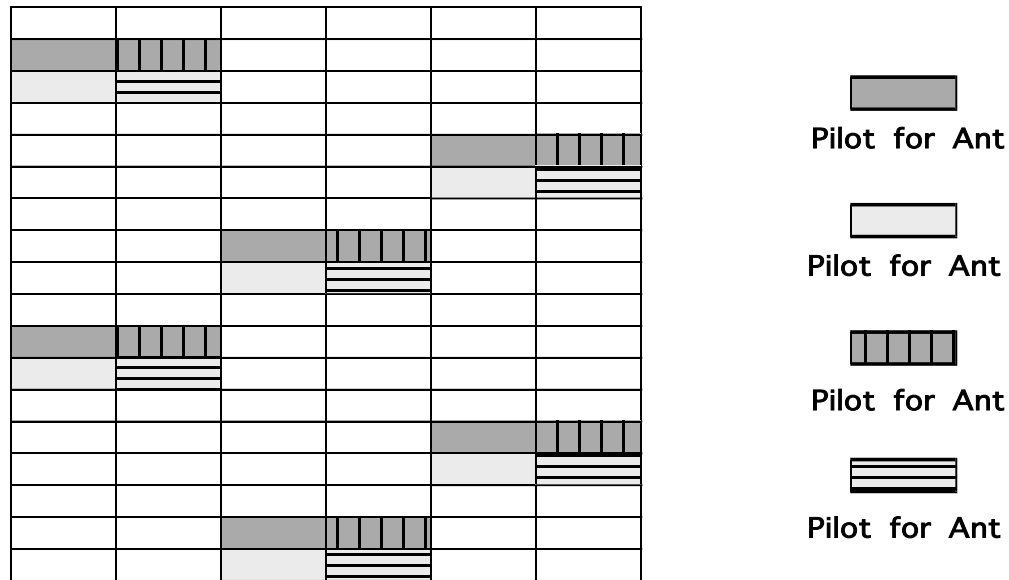

Figure ccc - Pilot allocation for 4-antenna BS for the optional FUSC and the optional AMC zones

#### 8.4.8.3.2 Allocation of data subchannels

In the optional FUSC zone with transmit diversity (TD) mode, the data subchannels shall be allocated for two consecutive OFDMA symbols. For the optional AMC zone and TD mode, the data subchannels shall be either 1x6 (1 bin in 6 symbols) or 3x2 (3 bins in 2 symbols) bin combination.

For transmit diversity (TD) mode with rate one, data subchannels shall be allocated as the following manner:

In the optional FUSC zone the data subchannels shall be allocated for two consecutive OFDMA symbols for 2 Tx using space-time block code (STBC). See 8.4.8.3.3. For 3 Tx and 4 Tx TD transmission mode, the data subchannel shall be allocated for two consecutive OFDMA symbols using two subcarriers. See 8.4.8.3.4 and 8.4.8.3.5.

In the optional AMC zone for 2-antenna TD transmission, the data subchannels shall be either 1x6 (1 bin for 6 symbols) or 3x2 (3 bins for 2 symbols) bin combination. For more than 2 antenna TD transmission, the data subchannels shall take 2x6 (2 bins for 6 symbols) format, in which 4 consecutive data symbols shall be frequency-time mapped using 2 adjacent subcarriers for 2 OFDMA symbols. When the subcarrier pair (over two symbols) at frequency  $k+1$  is allocated to pilots, then the pair at frequency  $k+3$  shall be jointly encoded with the pair at frequency  $k$ . See 8.4.8.3.4 and 8.4.8.3.5.

## 2.2. Optional PUSC and AMC for Uplink

Simulation results of STC for optional PUSC and AMC subchannels in the uplink are shown in this section, which provide rationality for the proposed pilot and data allocation schemes.

For the uplink PUSC performance, two pilot allocation schemes are considered and their transmit diversity performances for 2x2 (2 Tx – 2 Rx) are compared with 1x2 SIMO in Figure 2, 3 and 4. Case 1 in the Figures indicates no data puncturing so that the pilot overhead is 1/18 per antenna (Figure 1)

### Case 1

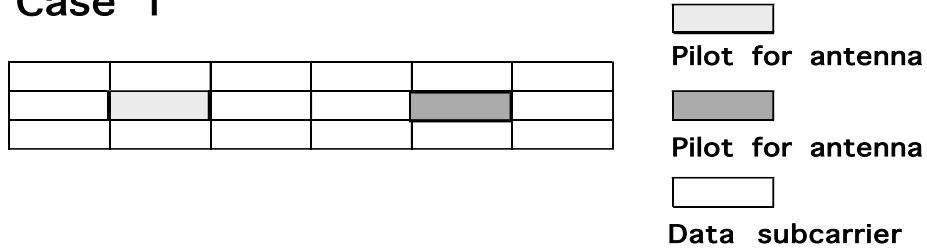

**Figure 1 Pilot Allocation Scheme for mini-subchannel type 01 : Case 1**

Case 2 is shown in Figure ddd where data subcarriers are punctured so that pilot density is increased to 1/9. In this case CTC or any other coding scheme is bound to suffer from puncturing loss. The purpose of simulation is two-fold: to show the transmit diversity gain over non-TD mode and to verify whether the improved channel estimation by added pilots can overcome the puncturing loss. The channel estimation method for this case is done by simple combining of two pilots for each mini-subchannel, and each pilot is boosted by 2.5 dB. In addition, for each MCS level, normalization error by a frame delay is introduced in order to capture the time variation of the channel.

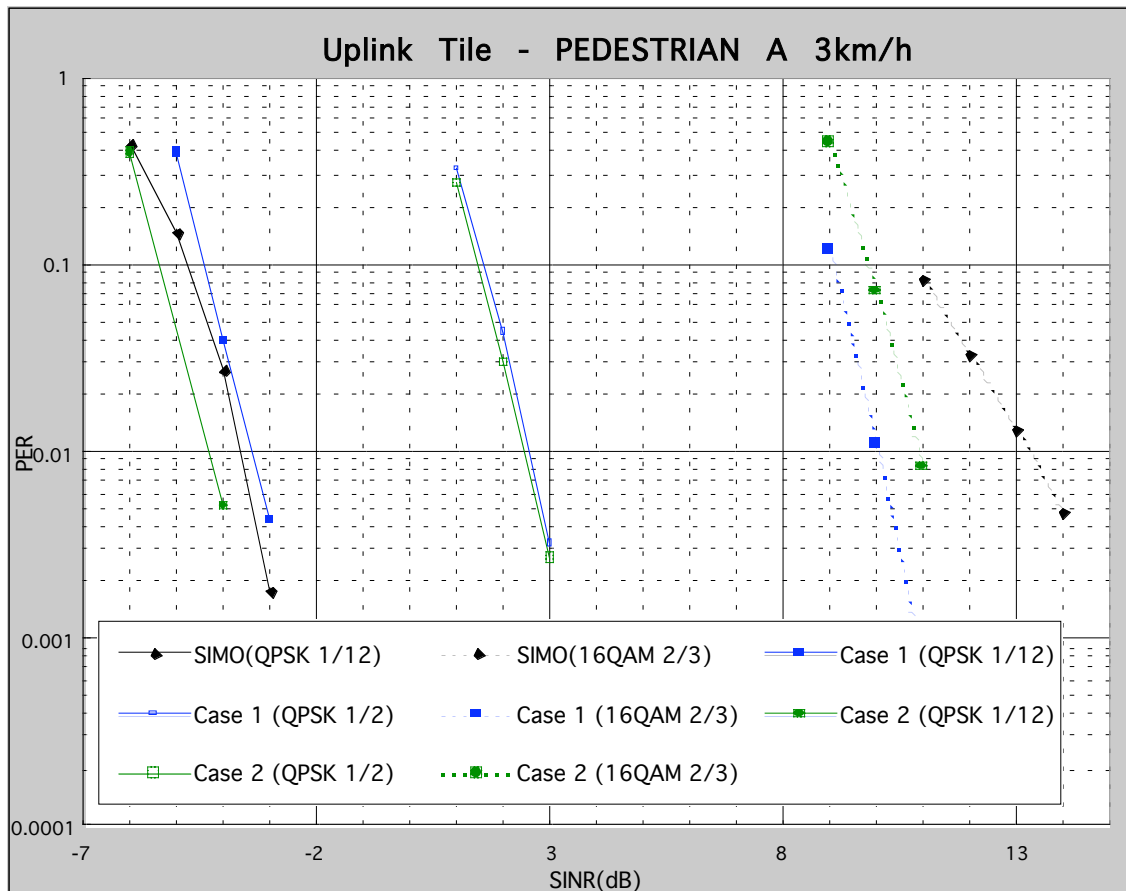

**Figure 2 Packet Error Rate of SIMO and MIMO (TD), uplink PUSC, CTC in Ped A 3 km/h**

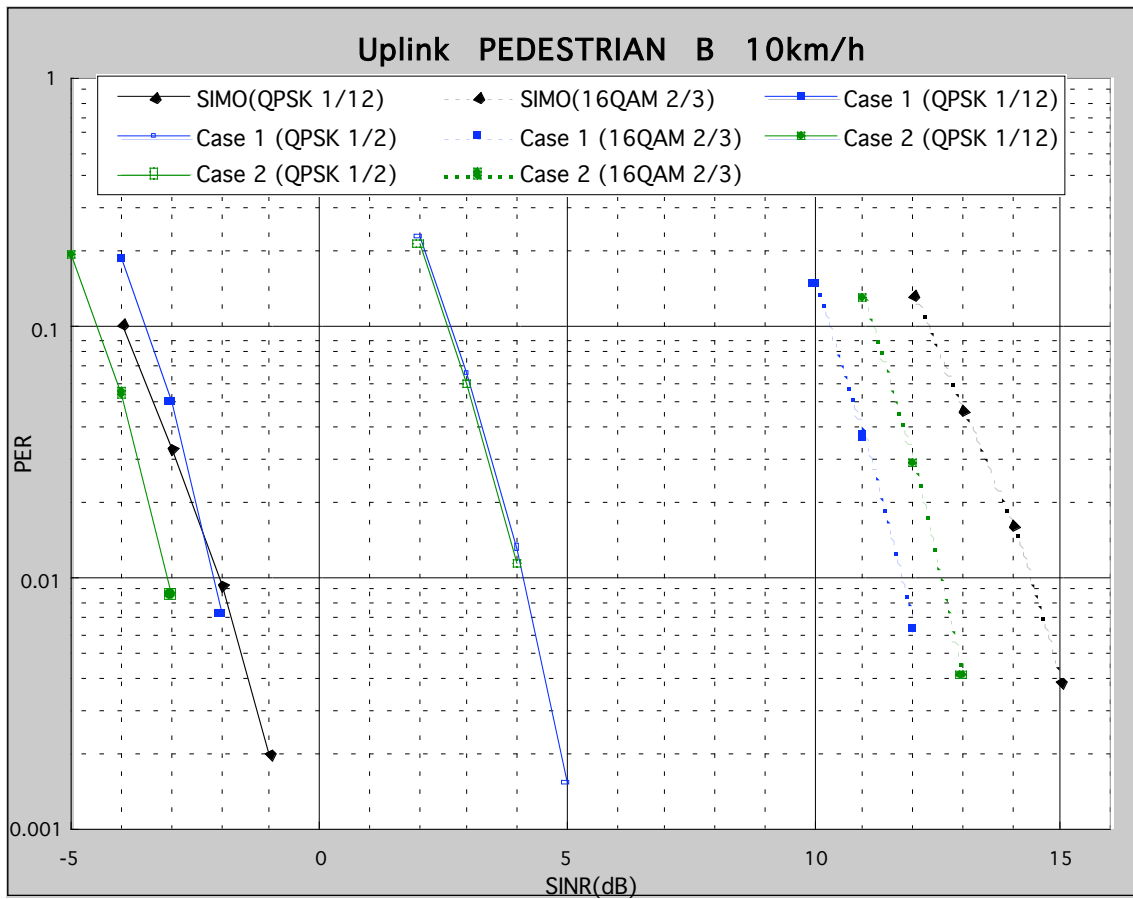
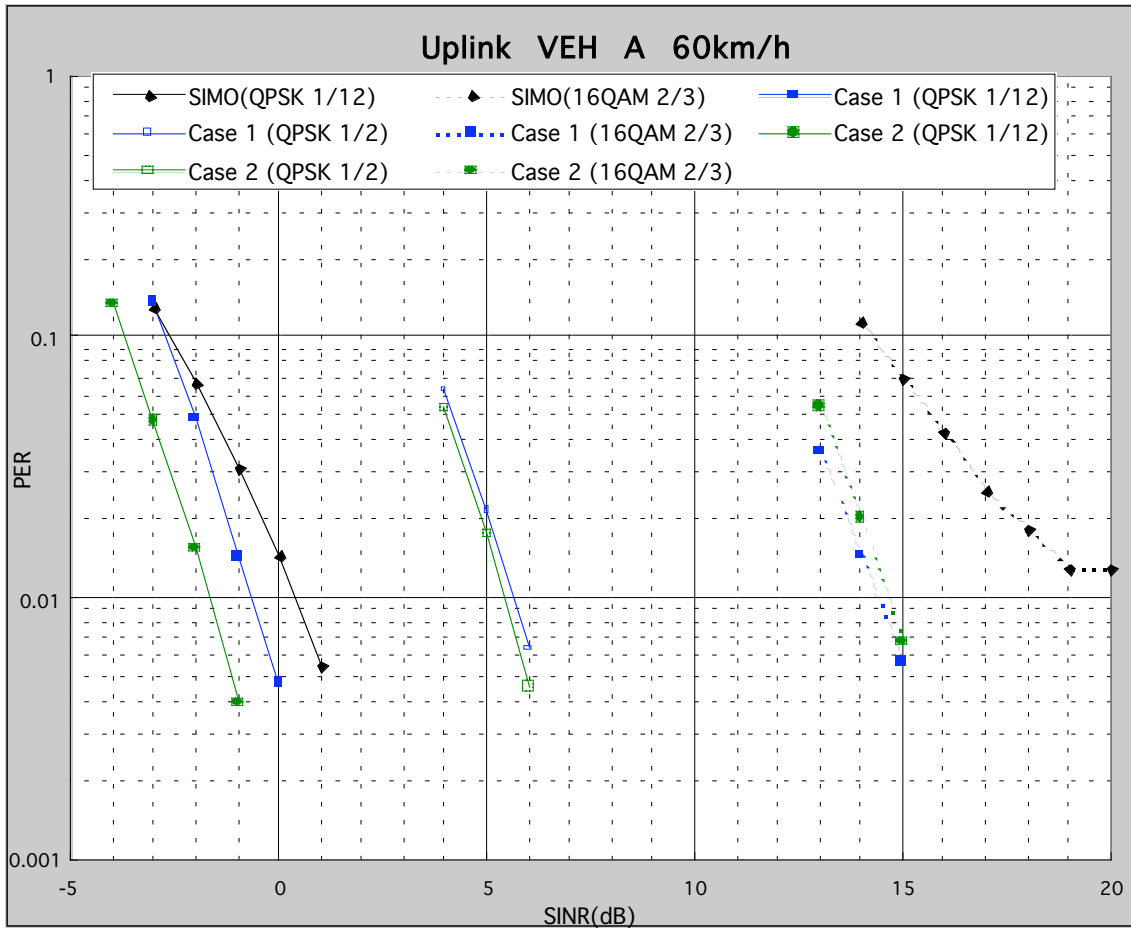

Figure 3 Packet Error Rate of SIMO and MIMO (TD), uplink PUSC, CTC in Ped B 10 km/h



**Figure 4 Packet Error Rate of SIMO and MIMO (TD), uplink PUSC, CTC in Veh A 60 km/h**

Figure 5, 6 and 7 compares the uplink band AMC performances of two channel estimation schemes, where 1x6 (1 bin over 6 OFDMA symbols) format is used. Method 0 uses the same estimation technique as the uplink PUSC mini-subchannels and method 1 has the additional sliding window in the frequency domain inside 1x6 subchannel.



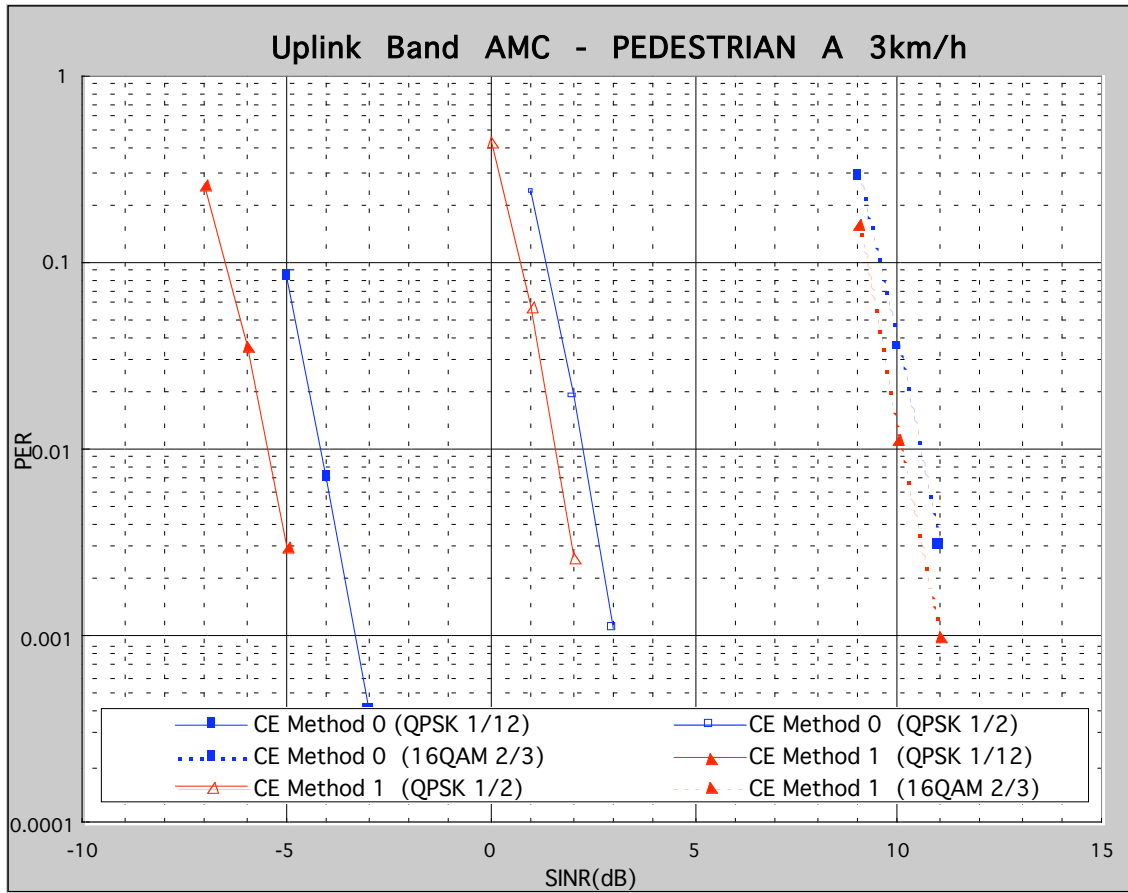

Figure 5 Packet Error Rate of 2x2 MIMO (TD), 1x6 AMC format, CTC, Ped A 3 km/h

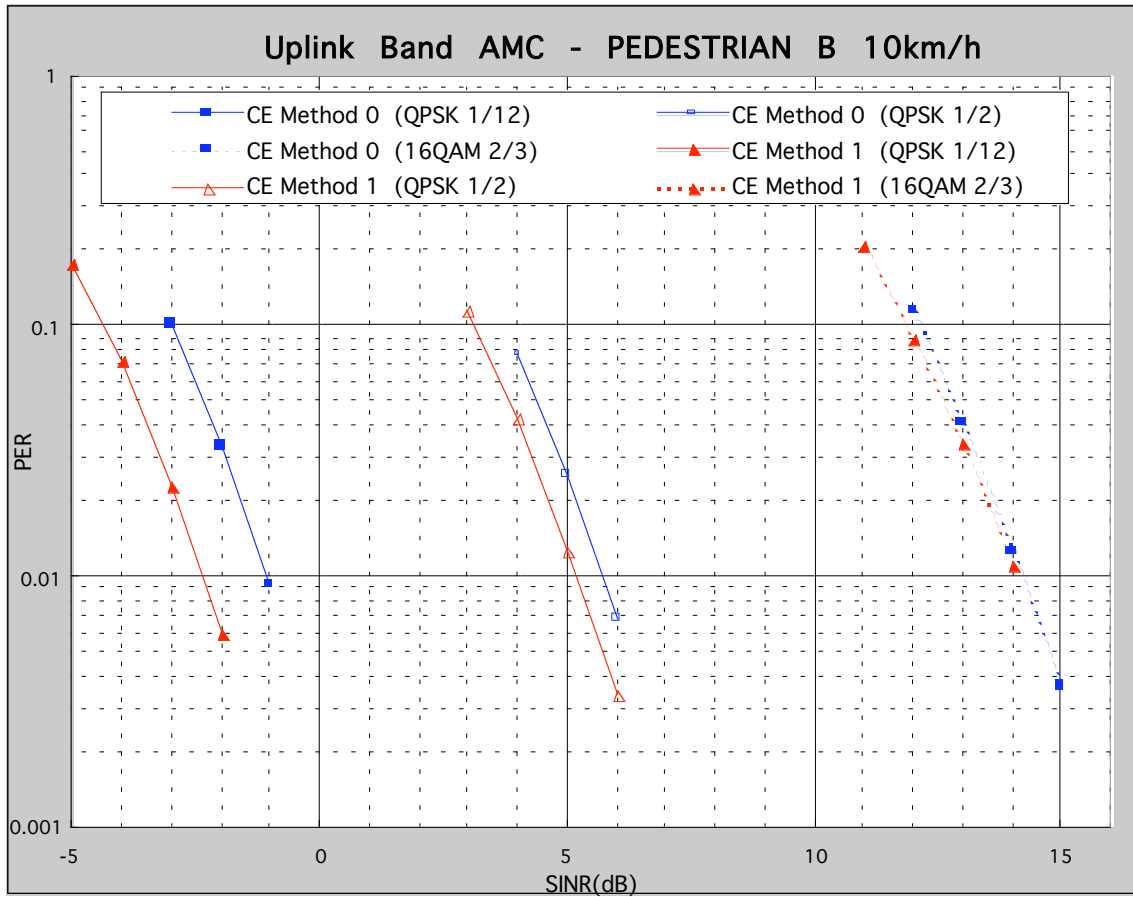

Figure 6 Packet Error Rate of 2x2 MIMO (TD), 1x6 AMC format, CTC, Ped B 10 km/h

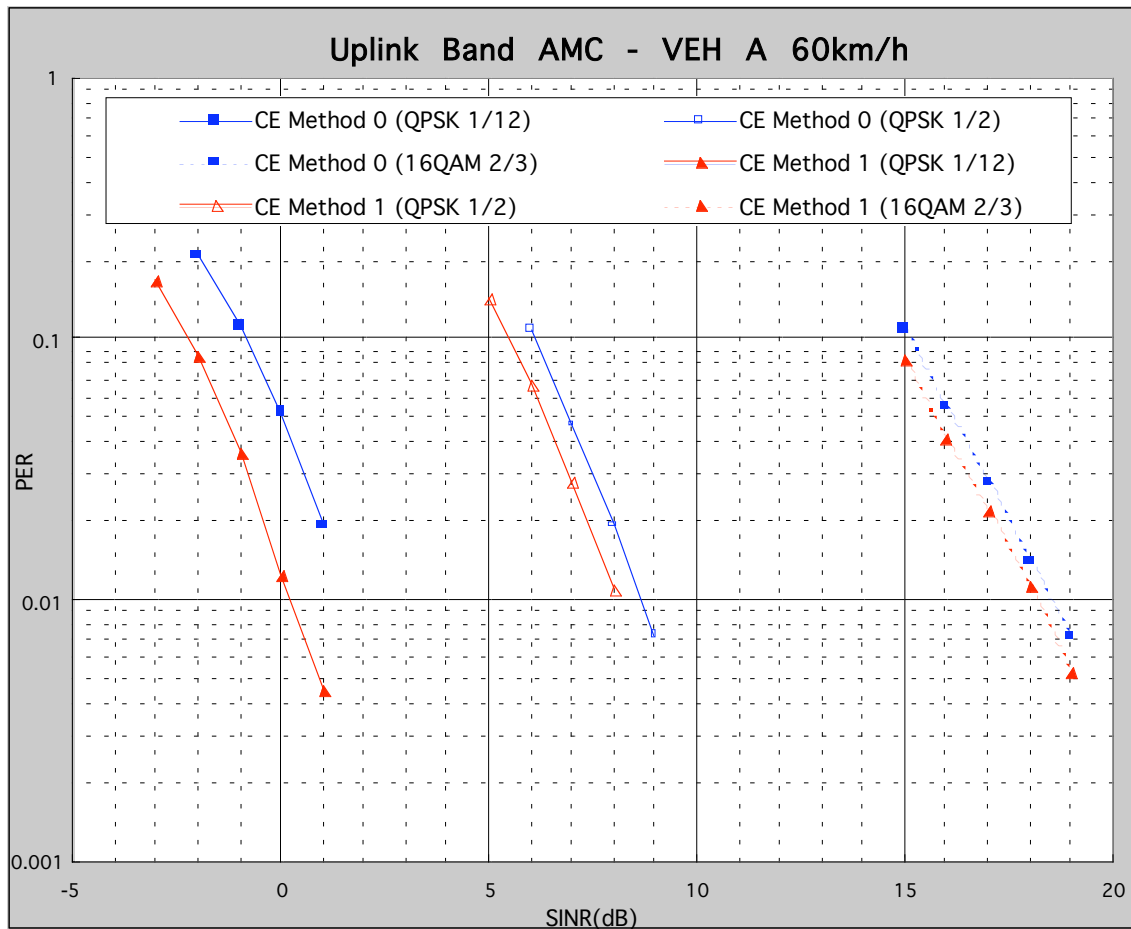

Figure 7 Packet Error Rate of 2x2 MIMO (TD), 1x6 AMC format, CTC, Veh A 60 km/h

## 2.2.1. Specific Text Changes

*[Add a new section 8.4.8.4]*

### 8.4.8.4 STC for the optional zones in the uplink

Two optional zones in the uplink, the optional PUSC and the optional AMC zones, are described in 8.4.6.2.5 and 8.4.6.3[2], respectively. STC may be used to improve system performance for these zones. Furthermore, two single transmit antenna SS's can perform collaborative spatial multiplexing onto the same subcarrier.

#### 8.4.8.4.1 Allocation of pilot subcarriers

For 2-antenna SS and the optional PUSC, pilots for each antenna shall be allocated as shown in Figure ddd.

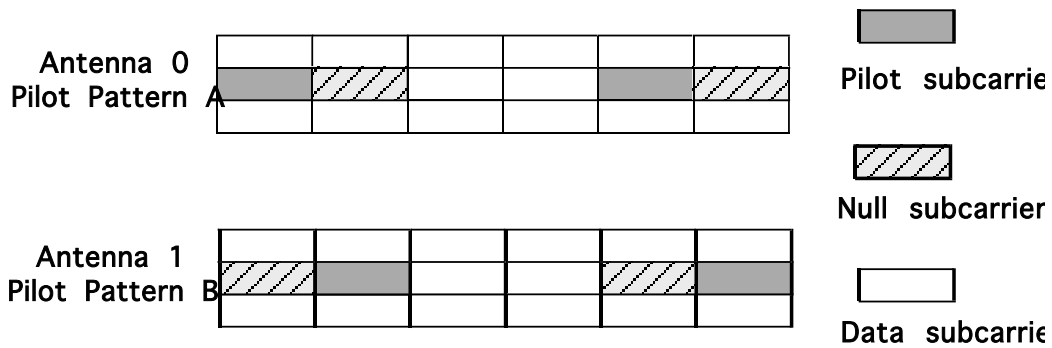

Figure ddd - Uplink pilot allocation for 2-antenna SS for the optional PUSC zones

~~For 2-antenna BS and the optional AMC, all pilots in the 1<sup>st</sup>, 2<sup>nd</sup>, 5<sup>th</sup> and 6<sup>th</sup> symbols shall be allocated for antenna 0, 1. This is shown in Figure eee.~~

For 2-antenna SS and the optional AMC, all pilots in the 1<sup>st</sup>, 5<sup>th</sup> symbols shall be allocated for antenna 0, while pilots in the 2<sup>nd</sup> and 6<sup>th</sup> symbols shall be allocated for antenna 1. This is shown in Figure eee.

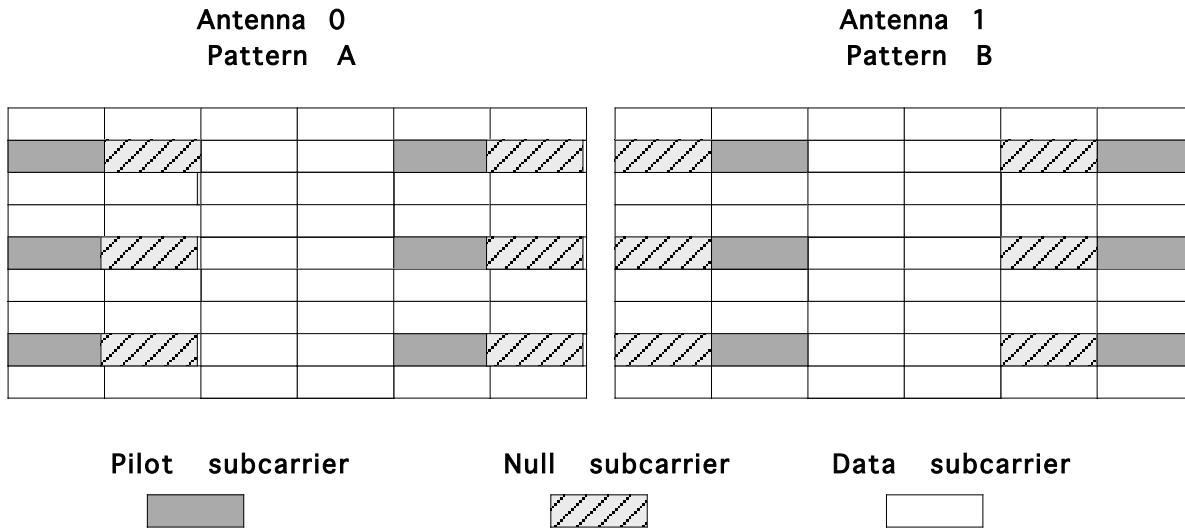

Figure eee - Uplink pilot allocation for 2-antenna SS for the optional AMC zones

Two single transmit antenna MSSs can perform collaborative spatial multiplexing onto the same subcarrier. In this case, one MSS should use uplink pilot allocation with pattern-A, and the other MSS should use the uplink pilot allocation with pattern-B.

#### 8.4.8.4.2 Allocation of data subchannels

In the uplink optional PUSC zone with transmit diversity (TD) mode, the data subchannels shall be allocated for mini subchannel (type 01) as shown in Figure eee. For the optional AMC zone with TD mode, the data subchannels shall take 1x6 (1 bin in 6 symbols) ~~or 3x2 (3 bins in 2 symbols) bin combination~~ format.

#### References:

[1] IEEE P802.16e/D3 Air Interface for Fixed and Mobile Broadband Wireless Access Systems – Amendment for Physical and Medium Access Control Layers for Combined Fixed and Mobile Operation in Licensed Bands

[2] IEEE P802.16-REVd/D5-2004 Draft IEEE Standards for local and metropolitan area networks part 16: Air interface for fixed broadband wireless access systems