

Project	<b>IEEE 802.16 Broadband Wireless Access Working Group</b> < <a href="http://ieee802.org/16">http://ieee802.org/16</a> >	
Title	<b>Clarification of SNR definition for MIMO</b>	
Date Submitted	<b>2004-11-04</b>	
Source:	Peiyong Zhu, Wen Tong, Jianglei Ma, Ming Jia, Dongsheng Yu, Hua Xu, Mo-Han Fong, Hang Zhang, Brian Johnson  Nortel Networks 3500 Carling Avenue Ottawa, ON. K2H 8E9 CANADA	Voice: (613)-765-8089 Fax: (613)-765-7723  <a href="mailto:pyzhu@nortelnetworks.com">pyzhu@nortelnetworks.com</a>
Re:	Response to Sponsor Ballot call for comment	
Abstract	In this contribution, we propose to feedback CQI based on SNR measured after MIMO decoder and before FEC encoder, so called post processing SNR to provide a unified approach for MIMO CQI measurement. In the proposal, we also clarify the multiple layer feedback using CQICH_Alloc_IE() or Enhanced_CQICH_Alloc_IE().	
Purpose	To incorporate the changes here proposed into the 802.16e D6 draft	
Notice	This document has been prepared to assist IEEE 802.16. It is offered as a basis for discussion and is not binding on the contributing individual(s) or organization(s). The material in this document is subject to change in form and content after further study. The contributor(s) reserve(s) the right to add, amend or withdraw material contained herein.	
Release	The contributor grants a free, irrevocable license to the IEEE to incorporate material contained in this contribution, and any modifications thereof, in the creation of an IEEE Standards publication; to copyright in the IEEE's name any IEEE Standards publication even though it may include portions of this contribution; and at the IEEE's sole discretion to permit others to reproduce in whole or in part the resulting IEEE Standards publication. The contributor also acknowledges and accepts that this contribution may be made public by IEEE 802.16.	
Patent Policy and Procedures	The contributor is familiar with the IEEE 802.16 Patent Policy and Procedures < <a href="http://ieee802.org/16/ipr/patents/policy.html">http://ieee802.org/16/ipr/patents/policy.html</a> >, including the statement "IEEE standards may include the known use of patent(s), including patent applications, provided the IEEE receives assurance from the patent holder or applicant with respect to patents essential for compliance with both mandatory and optional portions of the standard." Early disclosure to the Working Group of patent information that might be relevant to the standard is essential to reduce the possibility for delays in the development process and increase the likelihood that the draft publication will be approved for publication. Please notify the Chair < <a href="mailto:chair@wirelessman.org">mailto:chair@wirelessman.org</a> > as early as possible, in written or electronic form, if patented technology (or technology under patent application) might be incorporated into a draft standard being developed within the IEEE 802.16 Working Group. The Chair will disclose this notification via the IEEE 802.16 web site < <a href="http://ieee802.org/16/ipr/patents/notices">http://ieee802.org/16/ipr/patents/notices</a> >.	

# Clarification of SNR Definition for MIMO

## 1 Introduction

In the current standard, the BS assigns burst profile based on CQI feedback from MSS. For the SISO case, CQI is based on the SNR measured at the receive antenna port. However, for MIMO case, SNR measured at per-receive antenna does not provide enough information for this purpose. The channel burst profile selection depends on the type of MIMO decoder and channel matrix condition. In this contribution, we propose to feedback CQI based on SNR measured after MIMO decoder and before FEC encoder, so called post processing SNR as shown in Figure 1, therefore, provide a unified approach to CQI measurement with all the factors being taken into account. MSS may feedback either average post processing SNR or post processing SNR for individual layer as instructed by BS.

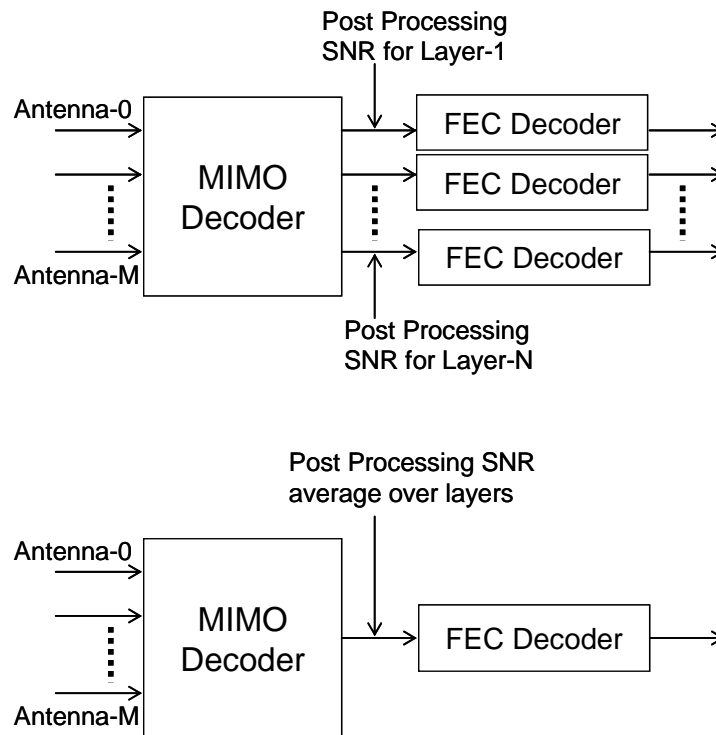

Figure 1 Post processing SNR

The current standard enables the spatial multiplexing MIMO transmission, it provides the feedback mechanism. However, when multiple layer feedback is enabled, the layer index is implied, not clearly specified. In the proposal, we add some text to clarify the multiple layer feedback using CQICH\_IE() or Enhanced CQICH\_IE().

## 2 Proposed text change

Modify the text in section 8.4.5.4.10.5

----- begin-----

When the FAST\_FEEDBACK subheader Feedback Type field is '00' or at a specific frame indicated in the CQICH\_Alloc\_IE() (see section 8.4.5.4.12, or the Feedback\_type field in CQICH\_Enhanced\_Alloc\_IE() is '00' (see 8.4.5.4.15), the SS shall report the S/N it measures on the DL. The following formula shall be used:  
 ----- end-----

Insert the following text in section 8.4.5.4.10.5 after line 65

-----Begin-----

MIMO capable MSS shall measure post processing S/N for each individual layers as shown in Figure xxx. When the FAST\_FEEDBACK subheader Feedback Type field is "00", the MSS shall report the post processing S/R averaged over layers. When BS requests MSS feedback through CQICH\_Alloc\_IE() or CQICH\_Enhanced\_Alloc\_IE() with '00' Feedback\_type field, MSS shall report average S/N or individual layer S/N as described in sections 8.4.5.4.12 and 8.4.5.4.15

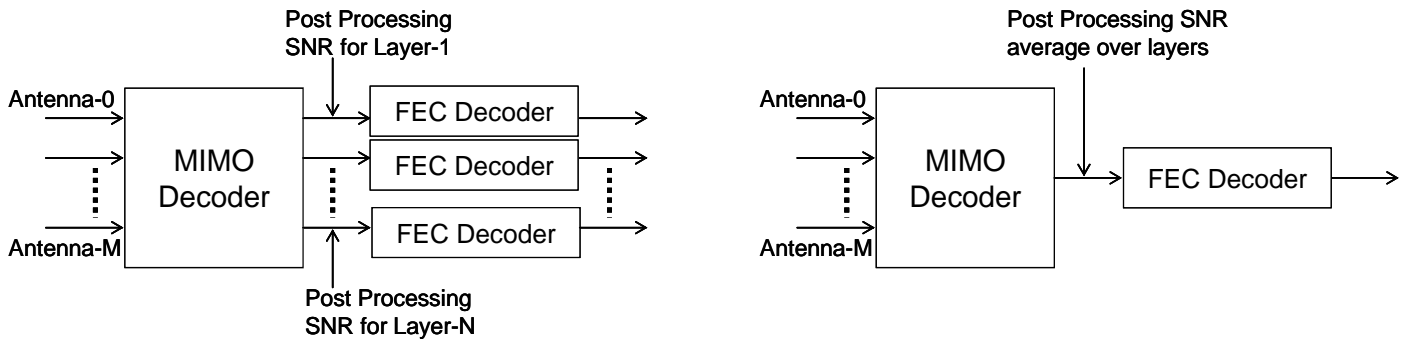

Figure XXX Post processed S/N for MIMO

For MSS with more than one receive antennas, the following formula shall be used

$$\text{Payload bits Nibble} = \begin{cases} 0 & S/N < -2 - \Delta dB \\ n & 2n - 2 - \Delta < S/N < 2n - 2 - \Delta dB \\ 15 & S/N > 26 - \Delta dB \end{cases} \quad 0 < n < 15 \quad (\text{xxx})$$

where  $\Delta = 10 \log(N_r)$  for the cases of single transmit antenna BS or 2 and 4 transmit antenna BS using matrix A transmission format and  $\Delta = 10 \log(N_r/2)$  for the case of 2 and 4 transmit antennas BS using matrix B transmission format.  $N_r$  is the number of receive antennas.

-----end-----

Modify the text in section 8.4.5.4.10.5 Fast DL measurement feedback for enhanced FAST\_FEEDBACK channel

----- begin-----

When the FAST\_FEEDBACK subheader Feedback Type field is '00' or at a specific frame indicated in the CQICH\_Alloc\_IE() (see section 8.4.5.4.12, or the Feedback\_type field in CQICH\_Enhanced\_Alloc\_IE() is '00' (see 8.4.5.4.15), the SS shall report the S/N it measures on the DL. The following formula shall be used:

----- end-----

*Insert the following text at the end of the section*

----- begin-----

For MSS with more than one receive antennas, the following formula shall be used

$$\text{Payload bits Nibble} = \begin{cases} 0 & S/N \leq -3 - \Delta dB \\ n & n - 4 - \Delta < S/N < n - 3 - \Delta dB \\ 31 & S/N > 27 - \Delta dB \end{cases} \quad 0 < n < 31 \quad (\text{yyy})$$

where  $\Delta = 10 \log(N_r)$  for the cases of single transmit antenna BS or 2 and 4 transmit antenna BS using matrix A transmission format and  $\Delta = 10 \log(N_r/2)$  for the case of 2 and 4 transmit antennas BS using matrix B transmission format.  $N_r$  is the number of receive antennas. S/N is post processing S/N averaged over layers as defined in section 8.4.5.4.10.5.

----- end-----

*Insert the following text in the end of section 8.4.5.4.12 CQICH Allocation IE Format to clarify the multi-layer CQI feedback for MIMO case*

----- begin -----

For MIMO capable MSSs, BS may allocate one or multiple CQICH channels to the MSS in UL\_MAP. If one CQICH channel is allocated, MSS shall report the average post processing S/R. If multiple CQICH channels are allocated, MSS shall report post processing SNR of individual layers, the order of CQICH channel allocation shall match the order of layer index.

----- end -----

*Insert the following text in the section 8.4.5.4.12.1 CQICH Enhanced Allocation IE Format*

----- begin -----

For MIMO capable MSSs, BS may allocate one or multiple CQICH channels to the MSS in UL\_MAP. If CQICH\_Num=0 and feedback type is '00', MSS shall report the average post processing S/R. For CQICH\_Num>0 and feedback type is '00', MSS shall report post processing SNR of individual layers, the order of CQICH channel allocation shall match the order of layer index..

----- end -----