

Source: IEEE P802.1 & P802.17 Working Group
Title: Communication to ITU-T SG15 from IEEE P802.1 & 802.17

COMMUNICATION STATEMENT

TO: Ghani Abbas, rapporteur Q9/15, ghani.abbas@marconi.com
Malcolm Betts, rapporteur Q12/15, betts01@nortel.com

COPY: Paul Nikolich, IEEE 802 Chair, p.nikolich@ieee.org

APPROVAL: Agreed to at IEEE P802.1 & P802.17 Plenary meeting, San Diego, July 2006
FOR: Information
DEADLINE: N/A
CONTACT: Mike Takefman, chair IEEE 802.17, tak@cisco.com
Tony Jeffree, chair IEEE 802.1, tony@JEFFREE.CO.UK

Subject: Ethernet Ring Protection
Reference: ITU-T Q9/15, Q12/15, Q5/3 Liaison LS01

We would like to thank you for your liaison that further explains your potential future work on Ethernet ring protection.

The 802.1 Working Group would like to draw your attention to the focus of our current work and the applicability of this to Ethernet rings. 802.1 continues its work on protection protocols (RSTP, MSTP and shortest path bridging) that are designed to provide rapid recovery following bridge or link failure for all types of services (e.g., point-to-point, point-to-multipoint, or multipoint-to-multipoint). However, 802.1 remains focused on configuration and reconfiguration of general mesh topologies, of which a ring may form part (or the whole). This focus is without regard to the particular optimizations available for point-to-point only, for ring only topologies only, or for any other subset of the general topology problem.

The work on P802.1aj (two port MAC relay) will include the propagation of MAC status to signal the failure of a link through multiple relays. It is possible that this work will be applicable to signaling failures of virtual links carried over various types of relays, including bridges configured in rings, as part of a follow-on, not yet approved project.

P802.1aq (shortest path bridging) will be designed to provide rapid recovery of VLAN based services over general topologies, including rings as mentioned previously. This project will include protocol development (including the use of link state protocol) that should further enhance reconfiguration performance.

The 802.17 Working Group would like to update you on our progress. We have approved to move P802.17b (spatially aware sublayer) to IEEE sponsor ballot (similar to ITU-T consent). In addition we have agreed that the next stage in the evolution of RPR is to consider inter-ring connection and protection. We will likely charter a study group on this topic at our November plenary and ITU-T experts are invited to join us.

To further assist you in understanding how Ethernet services can be carried over the 802.17 ring, we have attached some additional material in an appendix to this liaison. The appendix includes slides that highlight:

- RPR is a layer 2 packet ring protocol that is physical layer agnostic.
- Internetworking models for both bridging and IP/MPLS
- Frame formats showing the simplicity of carrying the Ethernet frame
- Spatially aware sublayer that improves ring efficiency for bridging
- Inter-ring connection and protection proposal

As we indicated in a previous liaison, 802.17 is willing to provide assistance should you require it during development of your recommendation to describe Ethernet ring protection using RPR.

We understand that you are studying the requirements for Ethernet rings and Ethernet ring protection. We would be interested in being informed if this study has resulted in the identification of a particular feature that is missing from 802.17 RPR that we could add to enable it to meet your requirements for Ethernet rings and Ethernet ring protection.

We wish to thank the leadership and the members of ITU-T SG15 for the inquiry into our work programs and look forward to the continuation of the exchange of information on topics of common interest to our organizations.

Regards,

Mike Takefman
Tony Jeffree

APPENDIX on RPR

802.17 Layer Structure

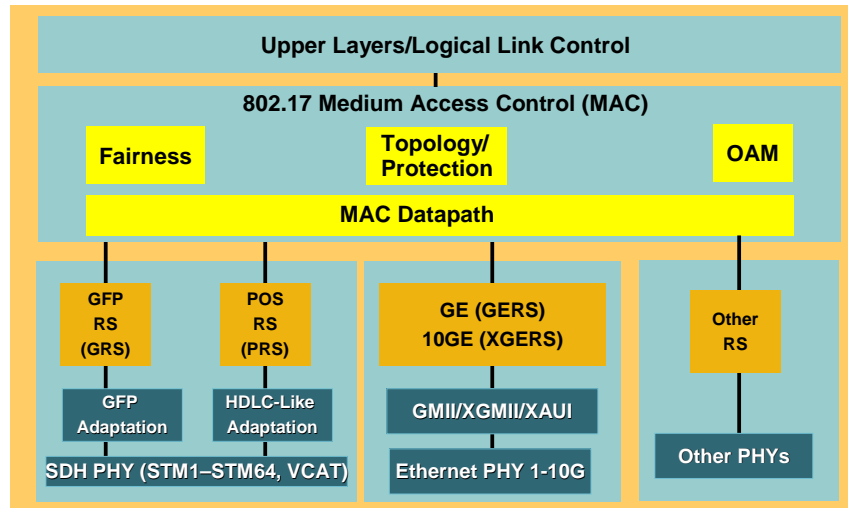

Ethernet Service over RPR: Protocol View

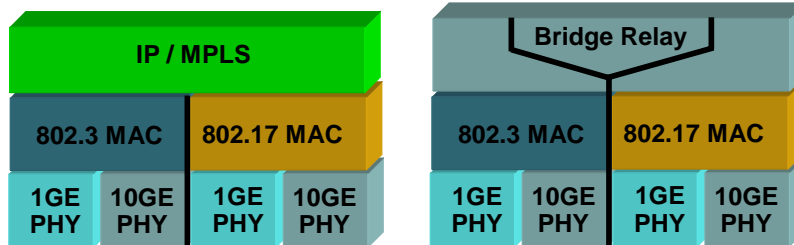

Architectural Characteristics:

Layer 3 Model

- IP/MPLS internetworking across ring

Layer 2 Model

- 802.1D bridging and learning
- 802.17b spatially aware extensions
- 802.1D/Q Internetworking

802.17 Protocol: Packet Format

Extended Packet Format: Bridging Operation

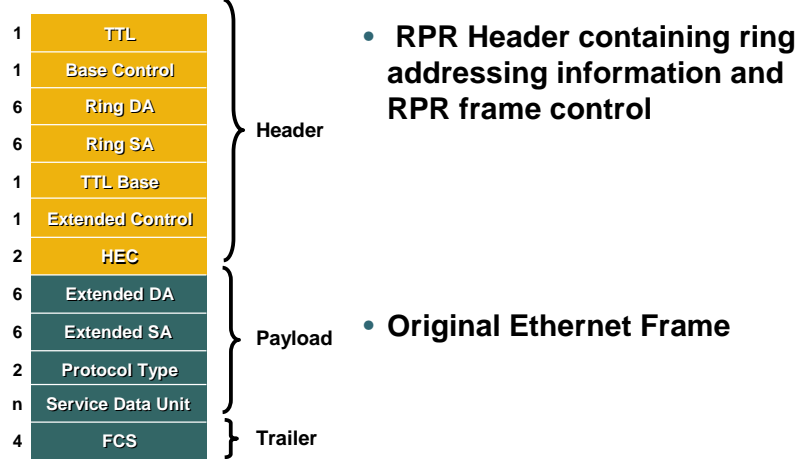

3

Ethernet Service over RPR : Frame Format View

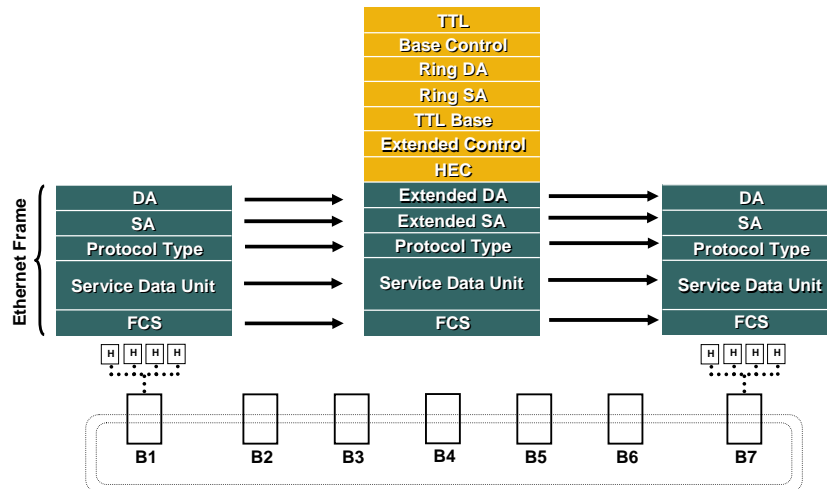

4

Layer 2 RPR Internetworking 802.17b Spatially Aware Sublayer

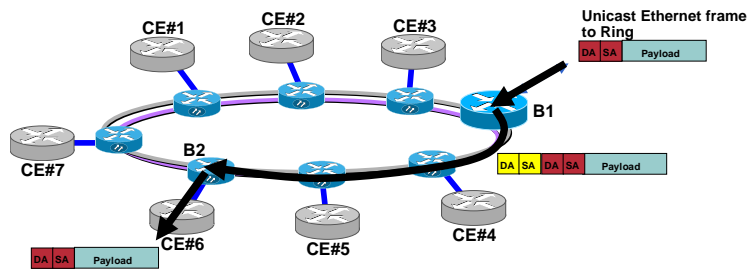

- Frame travel is scoped on the ring using the RPR MAC addresses to hold ring station DA/SA
- Stations running 802.17b learn MAC SA of stations in the CE Edge networks that are reachable on each ring port
- At the same time, the Ring Station SA from which the Frame originated is also stored in the FDB
- Once learned, the DA lookup provides the Ring Station MAC address behind which the host station resides. Frame travel can be scoped by using this address as the Ring DA.
- Spatial reuse is maintained

5

Proposed Project: Inter-Node Protection

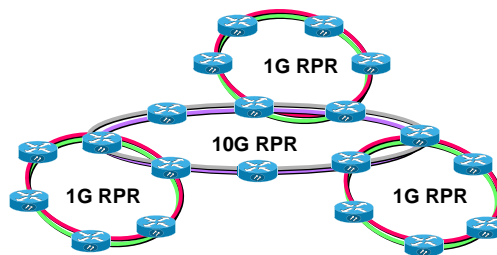

- Protection protocol that insures a forwarding path exists between rings by using multiple nodes
- Similar to subbanding rings with matched nodes in SDH/SONET

6