

6.2.2.1 High speed bit interleaving.

To date, TDM PON ONUs have had to fully process the aggregate downstream signal at line rate, regardless of how much traffic was actually being sent to the ONU. This is a source of inefficiency leading to higher power consumption compared to dedicated signals. A dynamic bit-interleaving protocol has been proposed [1],[2] wherein a decimator in the clock-data recovery (CDR) circuit extracts only a small proportion of the downstream bits containing the ONU payload, which avoids the need for wide parallel buses, significantly reducing the size of the ONU digital circuitry and its power consumption. In particular, the relatively intensive FEC processing can be done at the user rate.

ONUs cost-optimized for residential services might be limited to a fraction of the downstream bit rate, say 10 Gb/s. ONUs optimized for business services might be designed to have access to the full line rate, say 25 or 40 Gb/s. Both ONUs could be mixed on a PON and their bandwidths allocated dynamically, analogously to dynamic bandwidth allocation protocols already used in the upstream direction.

A simpler static bit interleaving could also be devised, although with reductions in power efficiency compared to dynamic bit interleaving. In this case the decimator ratio would be fixed, and its bit phase would be configured for each ONU. For example, a 40 Gb/s downstream/ 10 Gb/s upstream OLT and ONU could be implemented with 10G EPON logic, as shown in Figure 6.3.x-1. The down-side of static bit interleaving is that the ONU maximum downstream bandwidth is limited to the fixed decimation ratio (10 Gb/s in this example). This static implementation is analogous to wavelength-stacking in TWDM PONs, except a single OLT transceiver provides the full aggregate bandwidth and no wavelength agility or management is required.

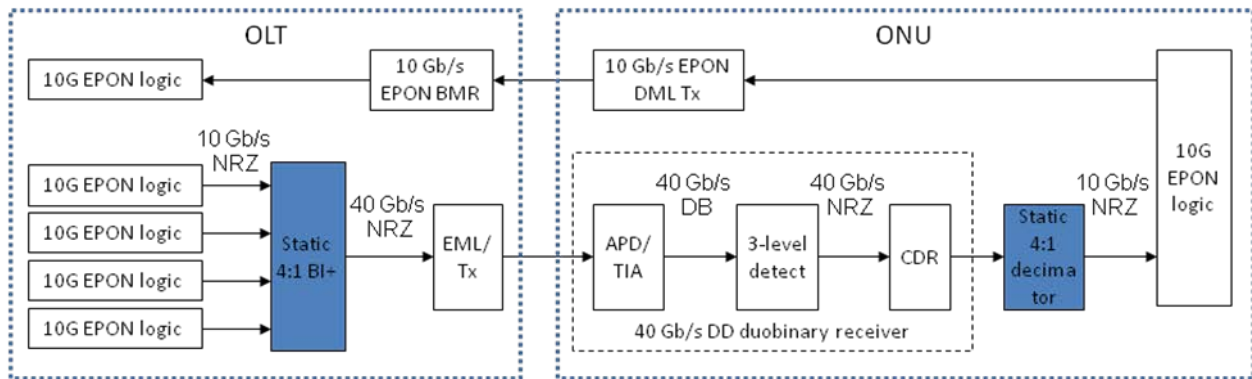

Figure 6.3.x-1. Example of simple static bit-interleaved PON.

[1] D. Suvakovic, H. Chow, D. van Veen, J. Galarró, B. Farah, N. P. Anthapadmanabhan and P. Vetter, “Low Energy Bit-Interleaving Downstream Protocol for Passive Optical Networks”, 2012 IEEE Online Conference on Green Communications (GreenCom), p.26-p31 (2012).

[2] D. Suvakovic, et. al., “A Low-Energy Rate-Adaptive Bit-Interleaved Passive Optical Network”, IEEE J. Selected Areas in Communications, v. 32, n. 8, Aug. 2014