



10GBASE-LRM over 300m of FDDI-grade Fiber

Experimental & Simulation Results

**Jonathan King
Sudeep Bhoja**

Outline

- System Simulations
 - Description of Model
 - Results (CL & OSL)
- System Experiments on TIA 12-96 Round Robin Fiber Set
 - Test set-up
 - PIE Metrics
 - Lab BER Results (CL & OSL)
- Discussion & Next Steps

Simulation Model

- Cambridge v1.1 81 fiber mode delays
- Cambridge 2.0 Mode Power Distribution
 - MPD for OSL at 1um steps
- 18 mode-groups were used in calculations

- PIE-L & PIE-D
 - 47.1ps rise-time Gaussian Tx filter
 - 7.5GHz, 4th-order Bessel-Thompson Rx filter

Simulation 81 Fiber Delay Set – PIE Metrics

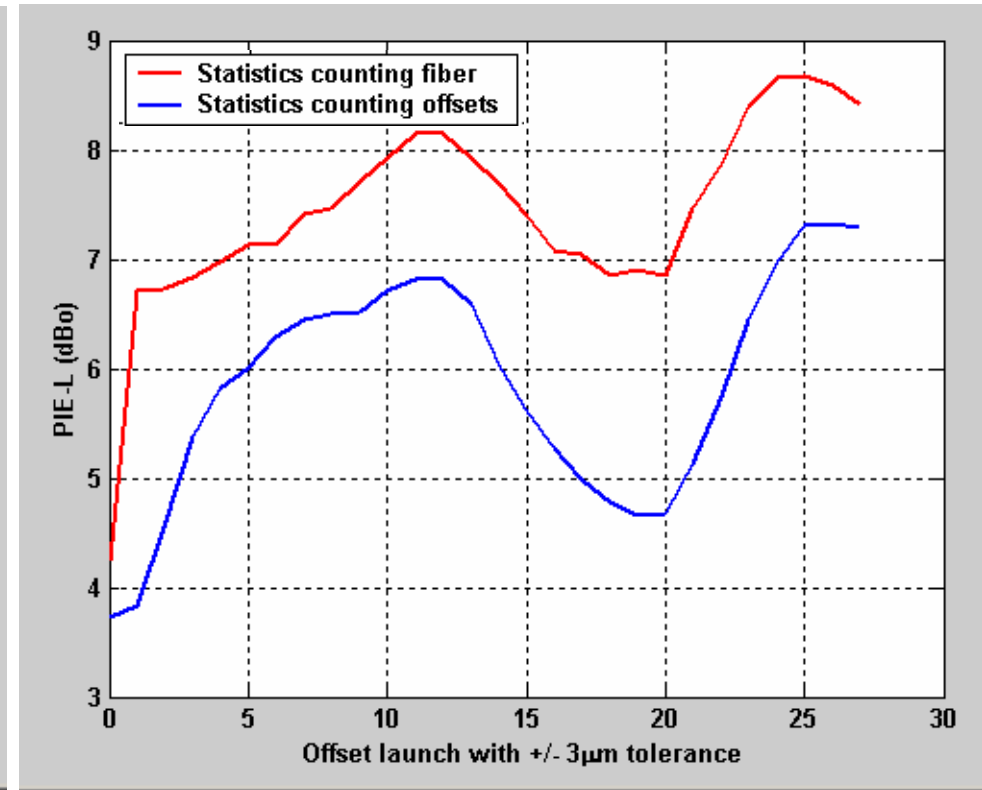
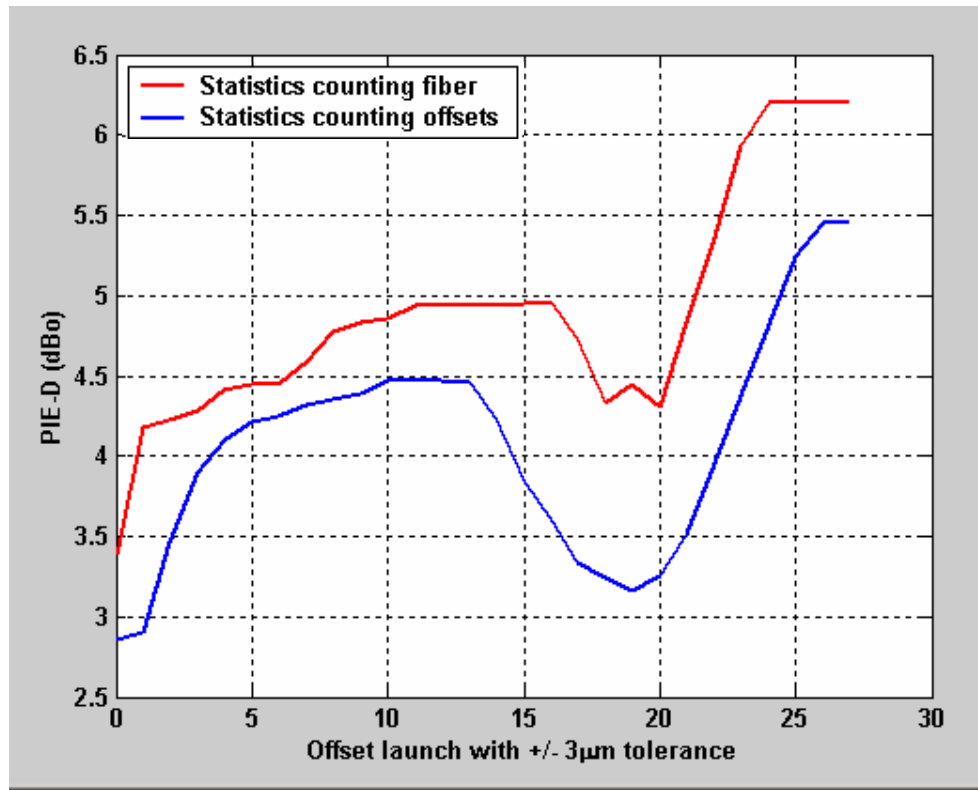

- DFE required to meet 300m distance requirements
 - Center Launch
 - 802.3z OSL (20 +/- 3µm)
- LE unlikely to meet 300m distance requirements
- Connectors are not included – likely to degrade performance

Experimental Comparison to TIA Round Robins

- “FO2-2 12/96 BW Modal Launch Test Cable”
 - Originally used for 1 Gigabit Ethernet round robin testing
 - E.g. 2orange, 4orange, ...
- 15 fibers - nine 62.5um & six 50um fibers
 - Nine 62.5um fiber results presented here
- All fibers 300m in length
- Recently used in measurement validation of the simulation model for Cambridge 81 fibre set (see cam_1_0504)
 - 4 fibres worse than 500MHz·km
 - Selection of causal, anti-causal and 'symmetric' impulse responses for OSL

Comparison of Cambridge model, an independently implemented Perturbation model and measured fibers

DMD 220 versus Mean DMD

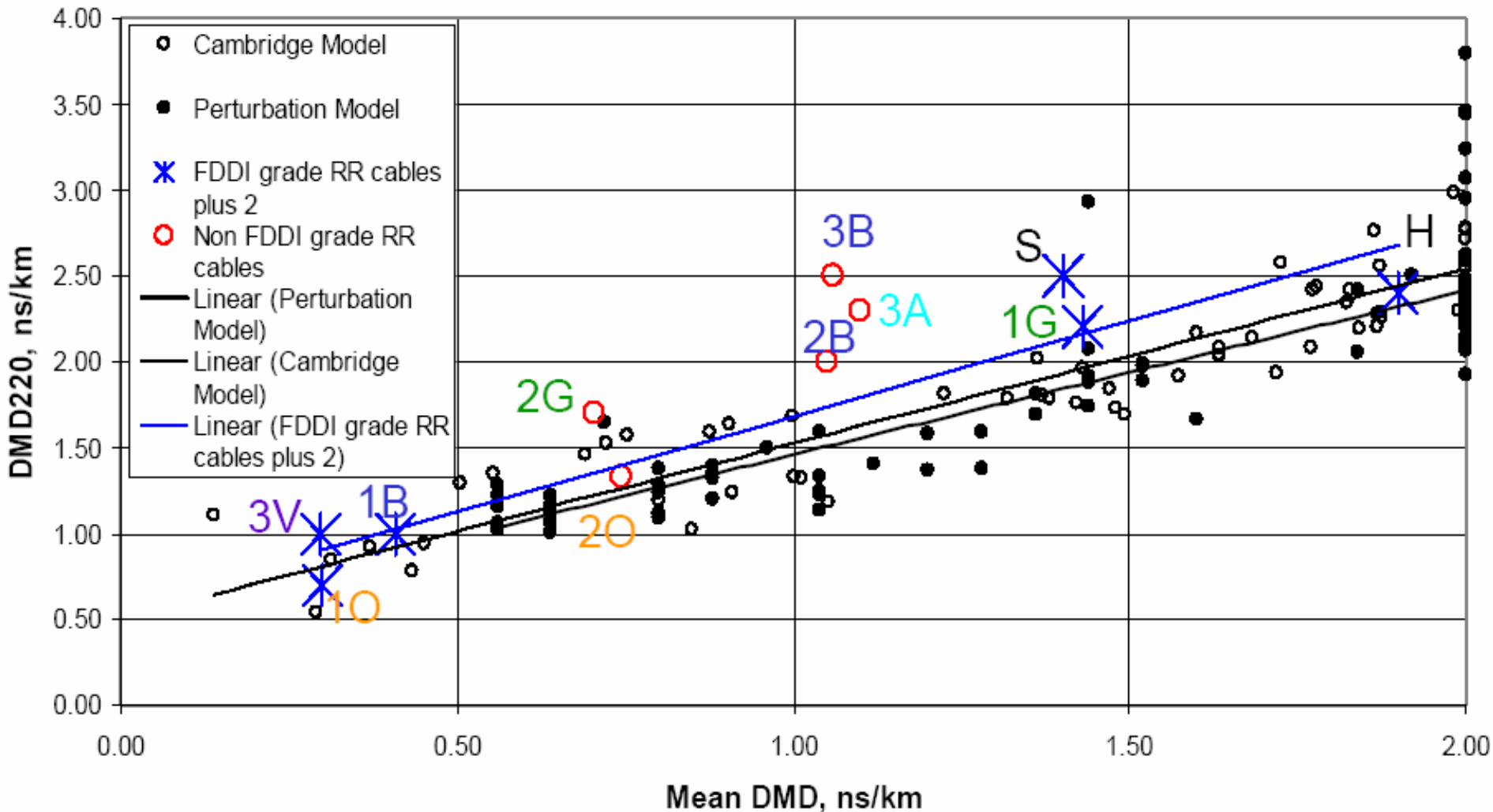

Strong correlation between measurements and theory

TIA 12-96 Fiber Set With OSL: 62.5um

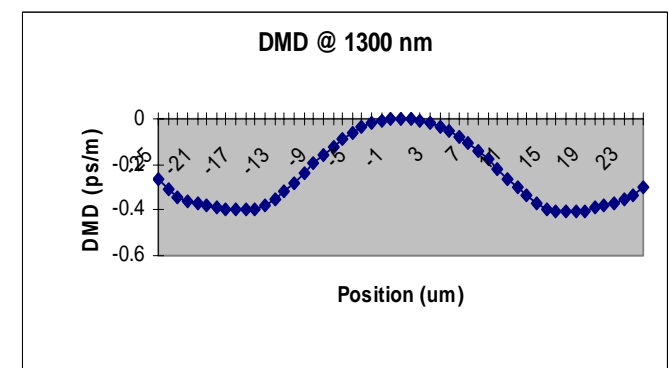
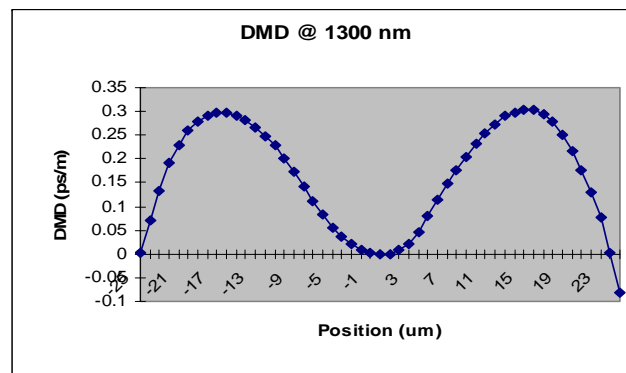
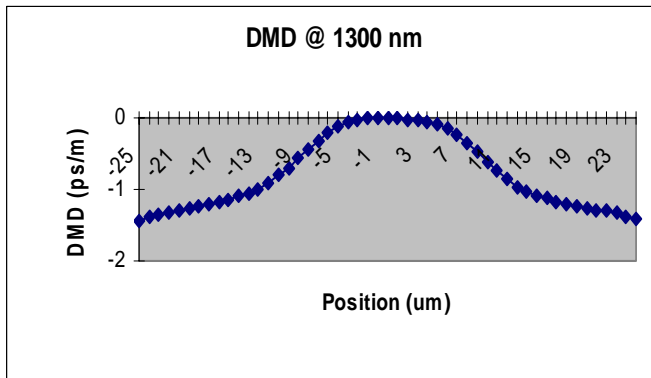
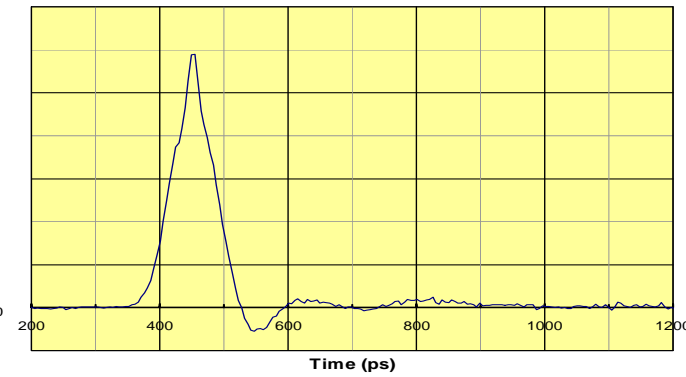
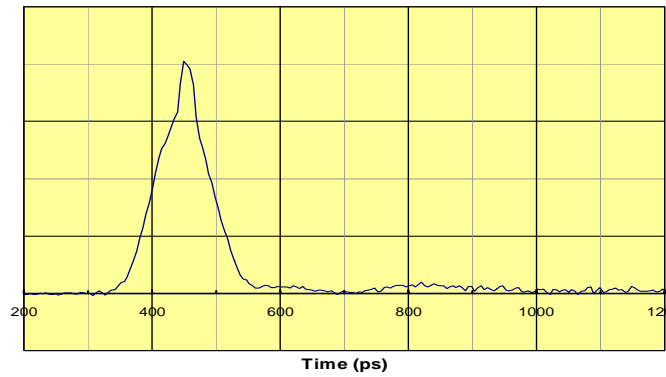
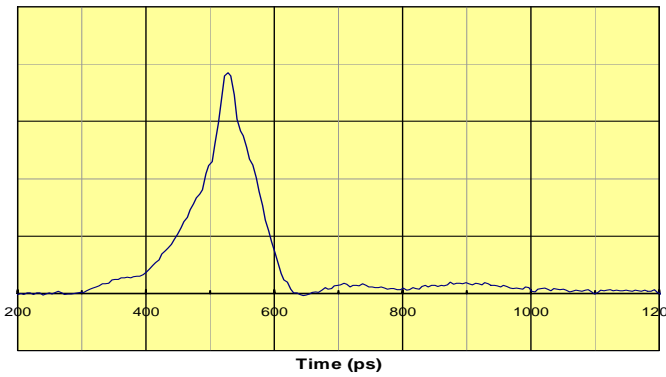
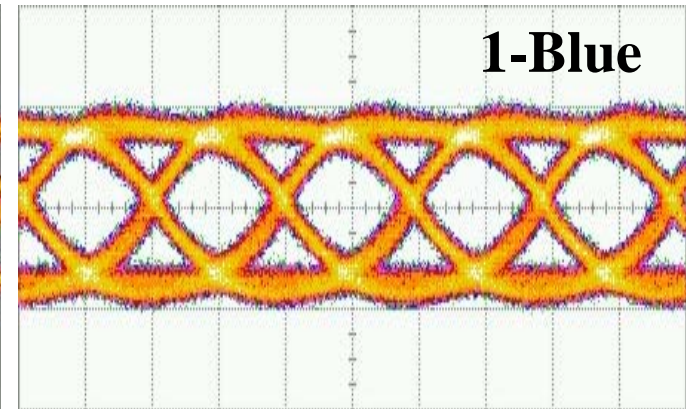
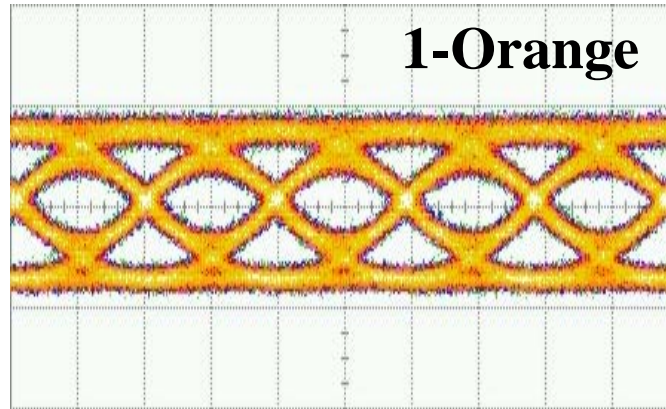
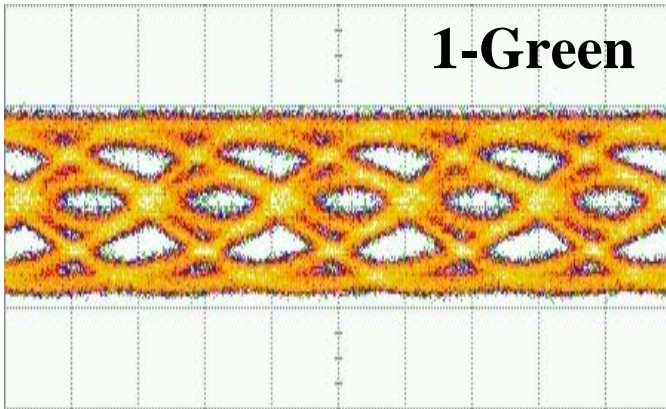

TIA 12-96 Fiber Set With OSL: 62.5um

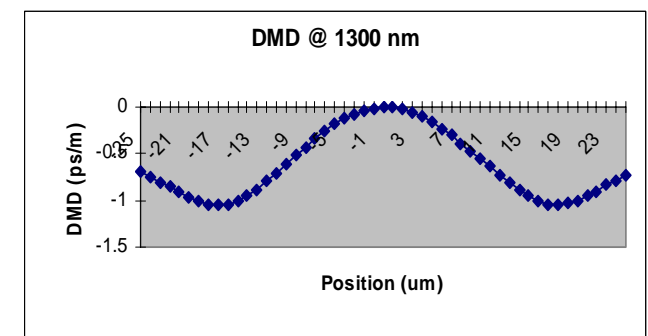
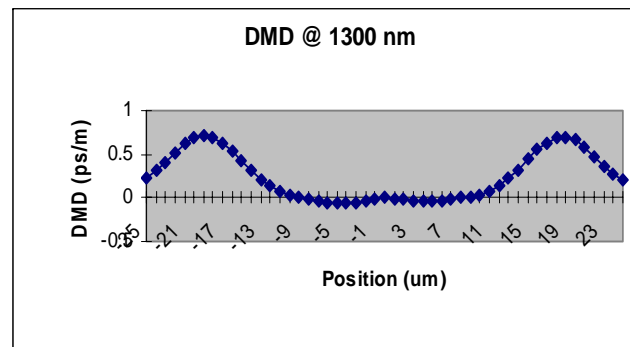
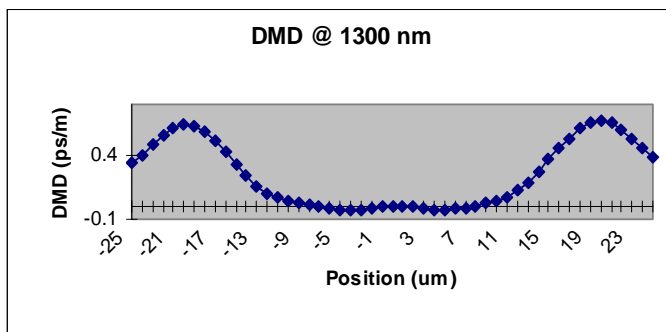
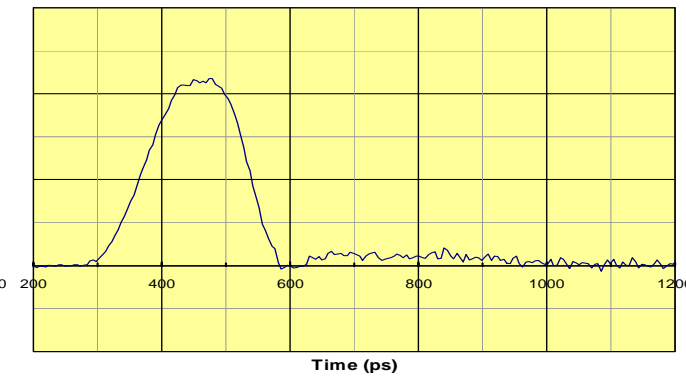
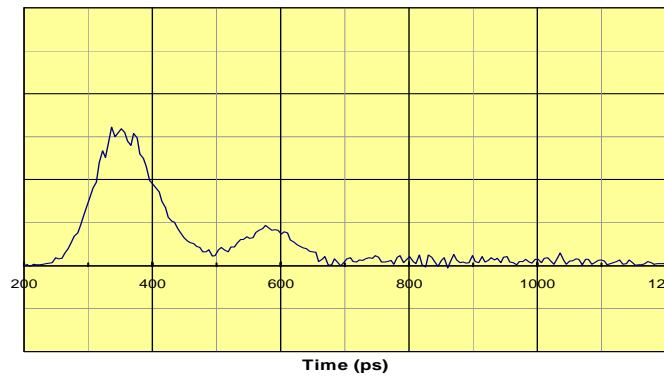
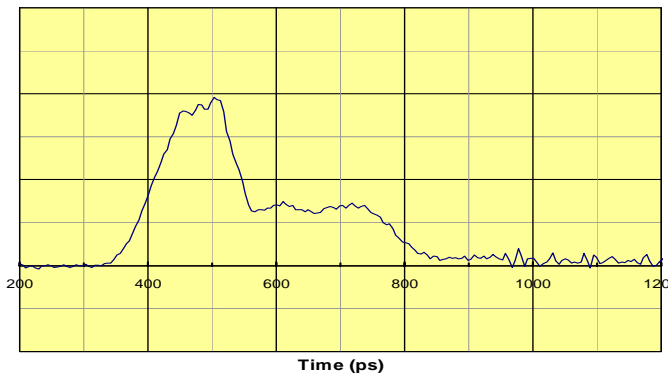
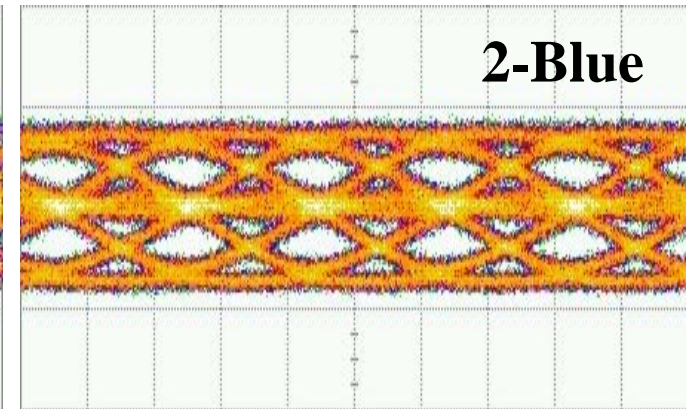
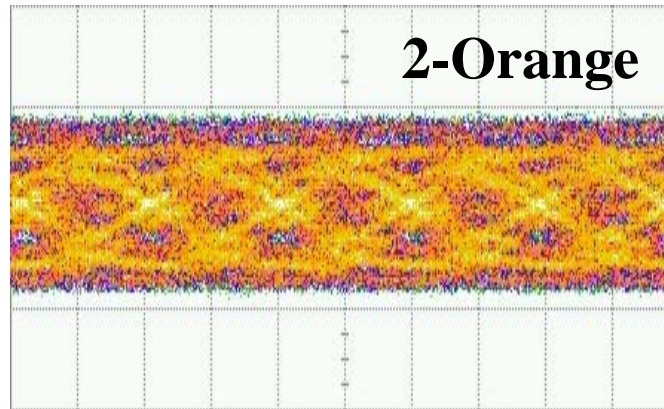
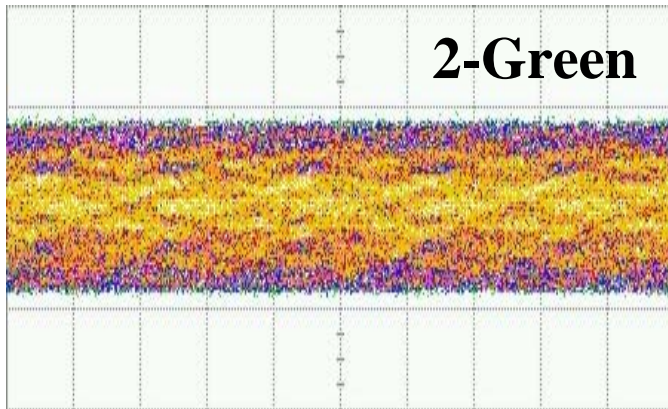

TIA 12-96 Fiber Set With OSL: 62.5um

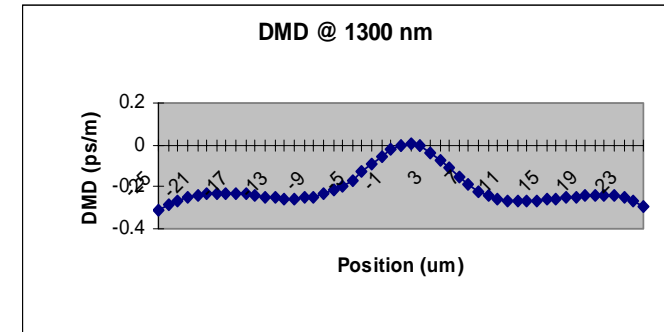
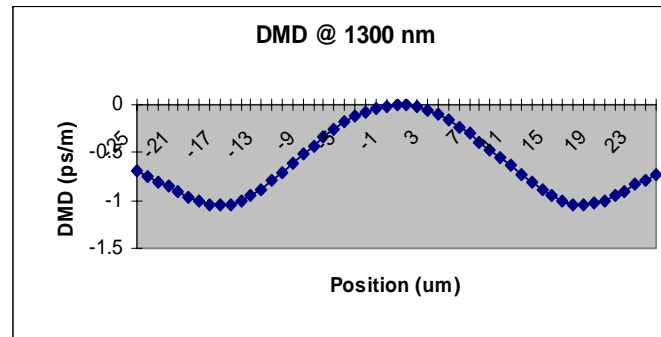
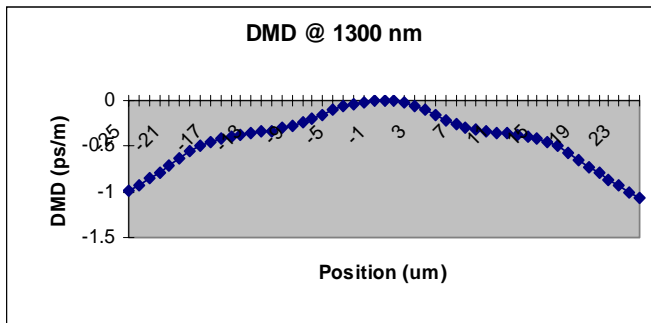
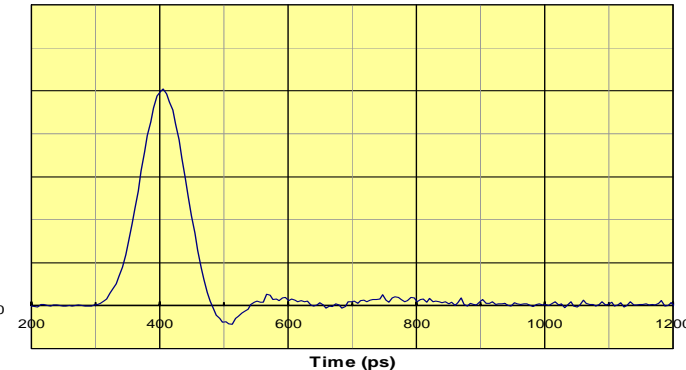
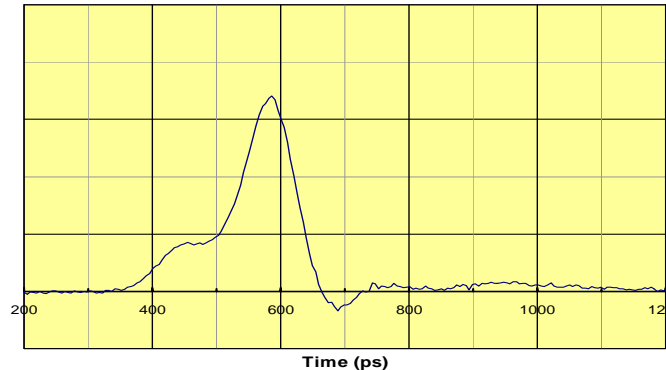
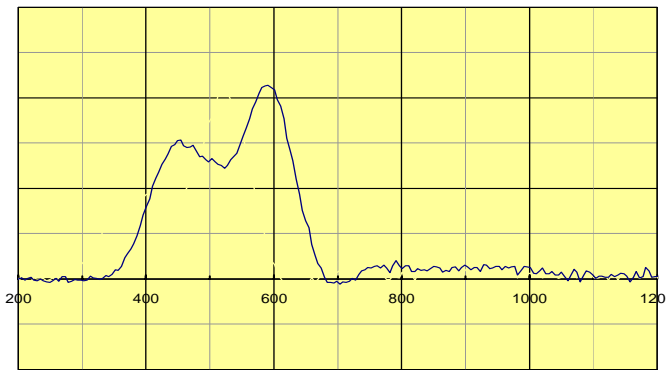
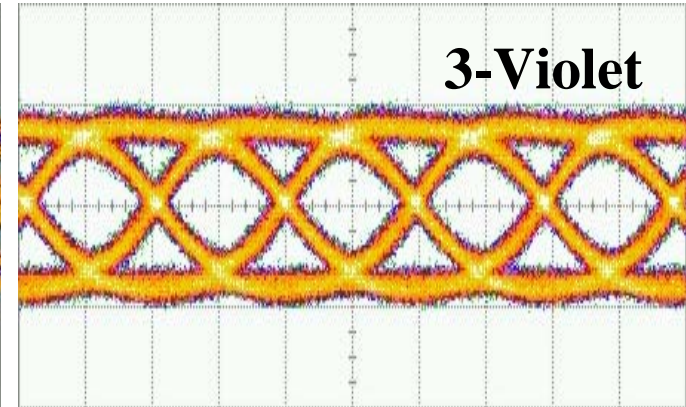
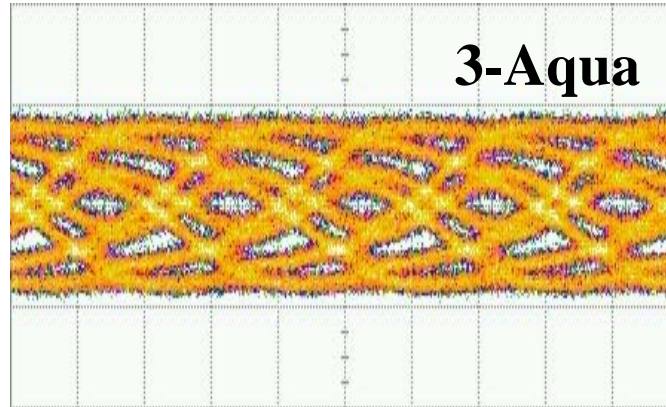
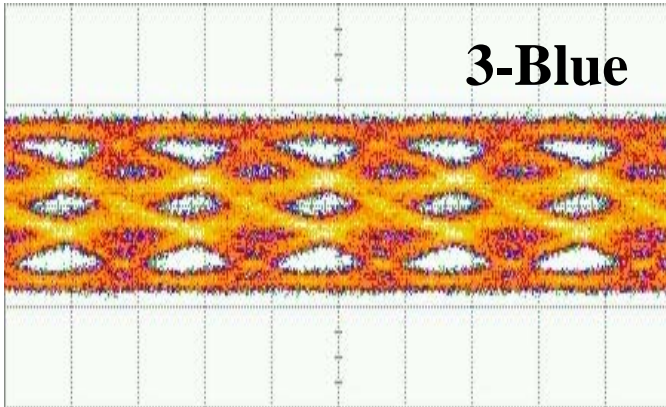

PIE Metrics: Test Set-up and Procedure

- Impulse response measured using gain switched DFB
 - CL, OSL (62.5um for all) launches, best and worst polarization / fibre configuration (labeled 'b' & 'w')
- Integrate impulse to get step response
- Delay step by 97.7ps, invert & subtract from original to yield isolated '1' bit response
- FFT, normalize DC component, and fold spectrum around 5.1GHz
- Piece-wise integration from 0 to 5.1GHz, following equations for PIE-L & PIE D (Bhoja_01_0704)

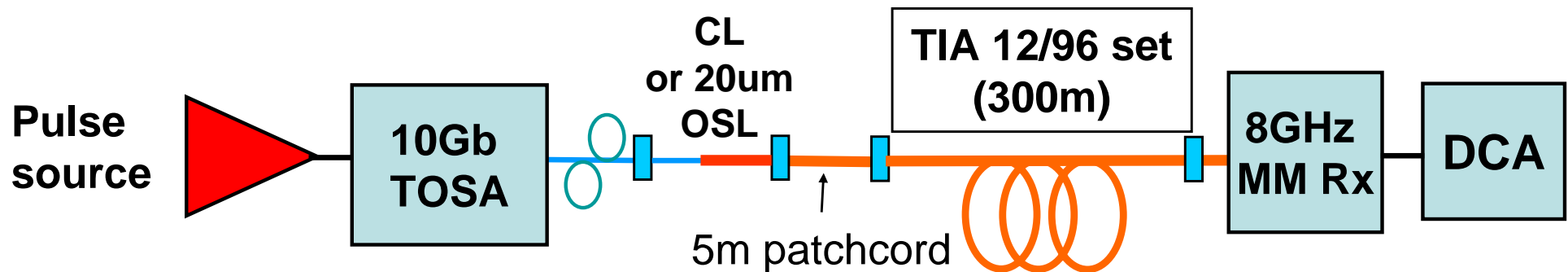

Summary Table: PIE-L & -D Metrics for 12-96 Set

Fibre	1 1orange	2 1green	3 1blu	4 2orange	5 2green	6 2blu	7 2aqua	8 3blu	9 3violet
OFL Bw MHz.km	998	756	2532	449	493	602	375	298	2582
CL Bw, MHz.km	2787	352	2785	2785	2785	2785	637	701	2783
CL b, PIE-L	2.16	1.57	1.43	2.4	2.62	3.12	2.27	2.41	1.95
CL w, PIE-L	3.88	3.83	2.04	3.73	3.02	5.45	5.1	5.57	4.98
CL b, PIE-D	1.82	1.47	1.26	1.9	2.05	2.82	2.04	2.12	1.76
CL w, PIE-D	2.7	3.33	1.7	2.62	2.26	4.42	3.82	4.18	3.52
OSL b, PIE-L	2.58	4.17	1.7	5.42	9.48	6.99	5.12	6.78	1.26
OSL w, PIE-L	2.58	4.77	1.7	5.95	10.41	8.39	5.53	7.3	1.34
OSL b, PIE-D	2.09	3.26	1.49	4.52	6.98	4.81	3.83	4.88	1.12
OSL w, PIE-D	2.09	3.63	1.49	4.87	7.46	4.98	4.0	5.02	1.34

12-96 Set PIE Metrics for CL

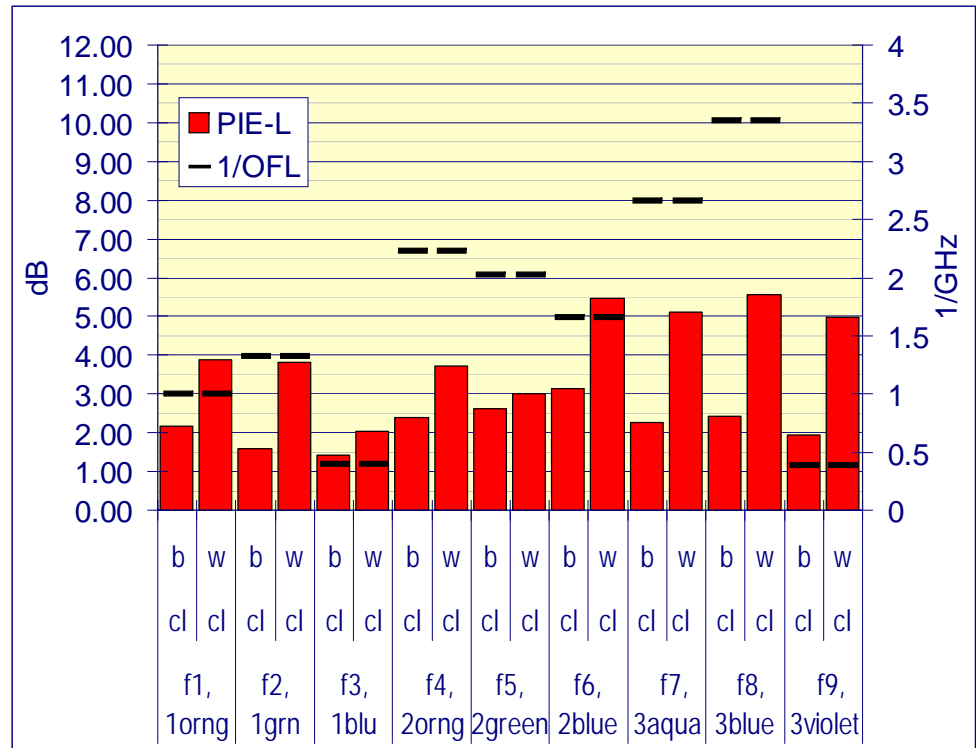
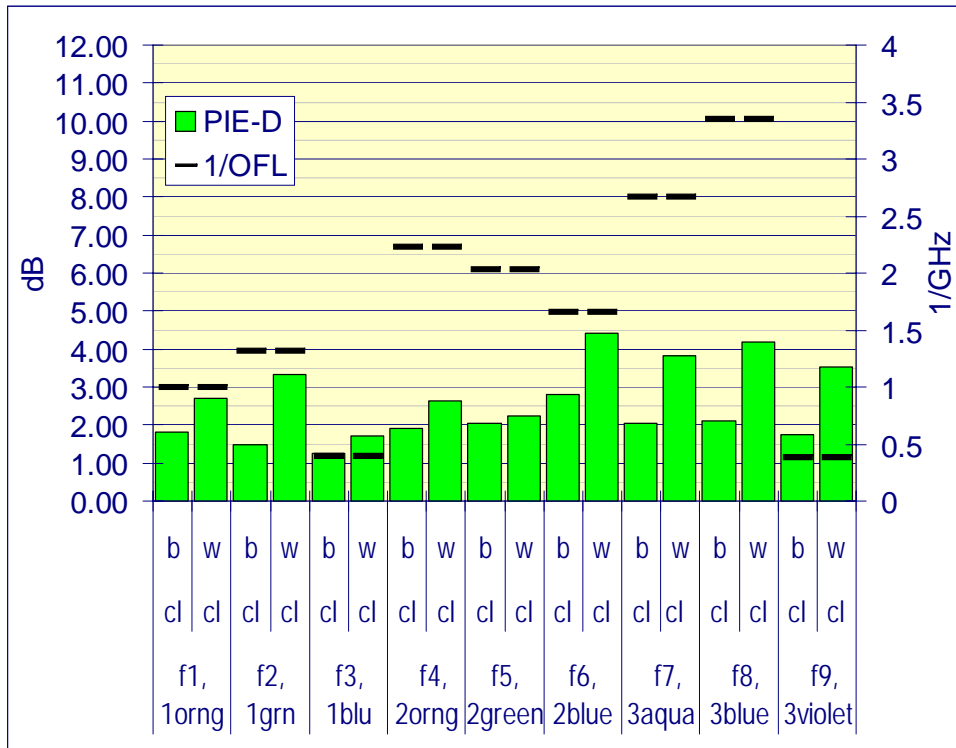

All fibres below 4.5dB PIE-D for best and worst case IPR

5/9 fibres below 4.5dB PIE-L for best and worst case IPR & all fibres below 5.6dB

Note: Connector off-sets are not included – likely to degrade performance

12-96 Set PIE Metrics for 20um OSL

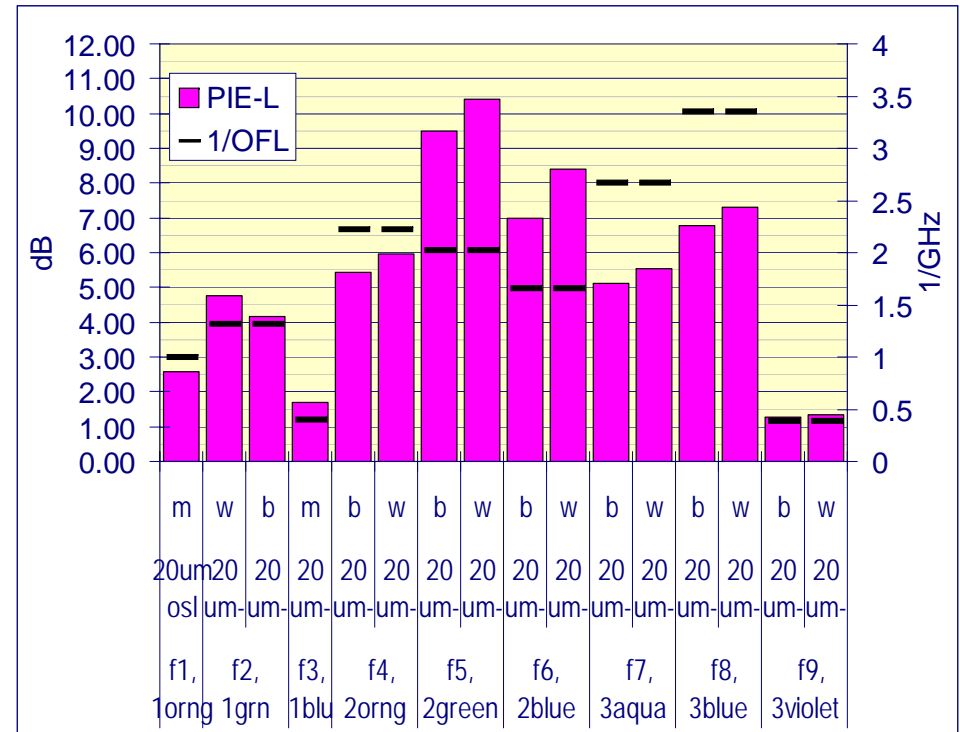
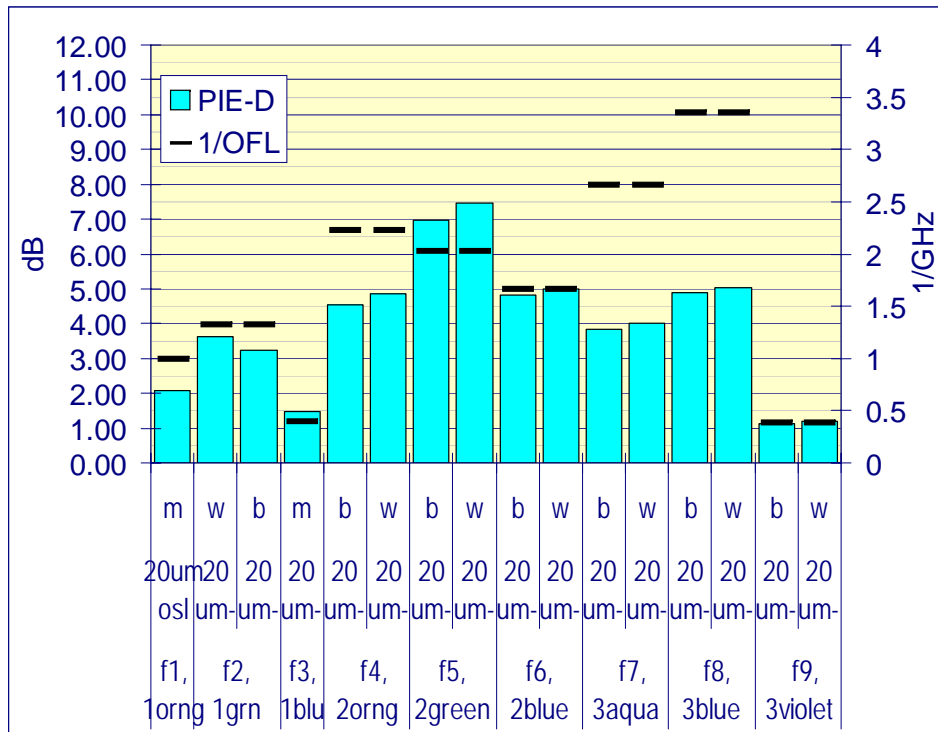

4/5 compliant fibres (OFL Bw>500MHz) below 4.5dB PIE-D for best and worst case IPR
All compliant fibres <5dB

3/5 compliant fibres (OFL Bw>500MHz) below 4.5dB PIE-L for best and worst case IPR
All compliant fibres <8.5dB

10.3Gb/s System Test Bed

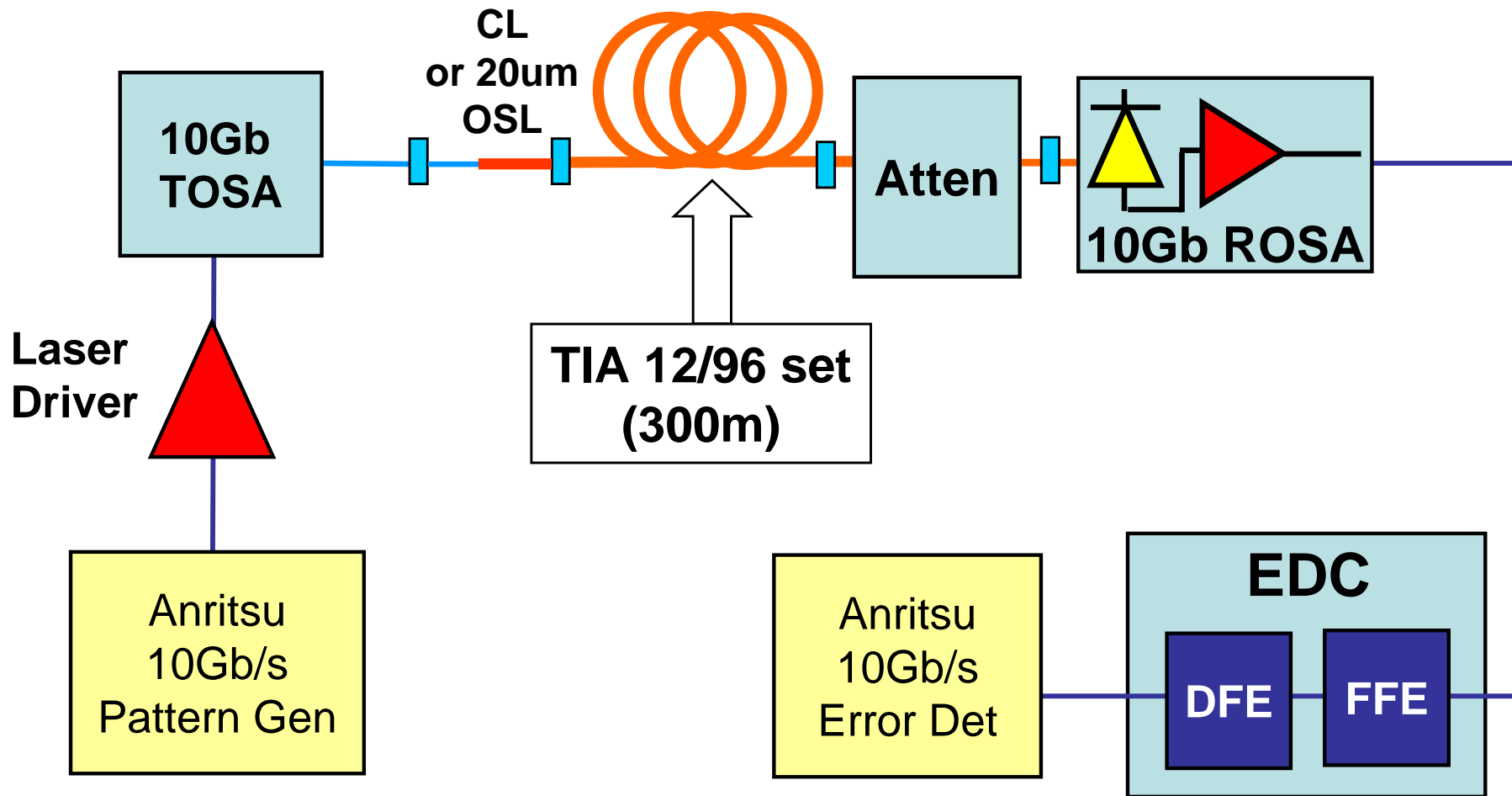

TIA 12-96 300m MMF Round Robin: CL Results

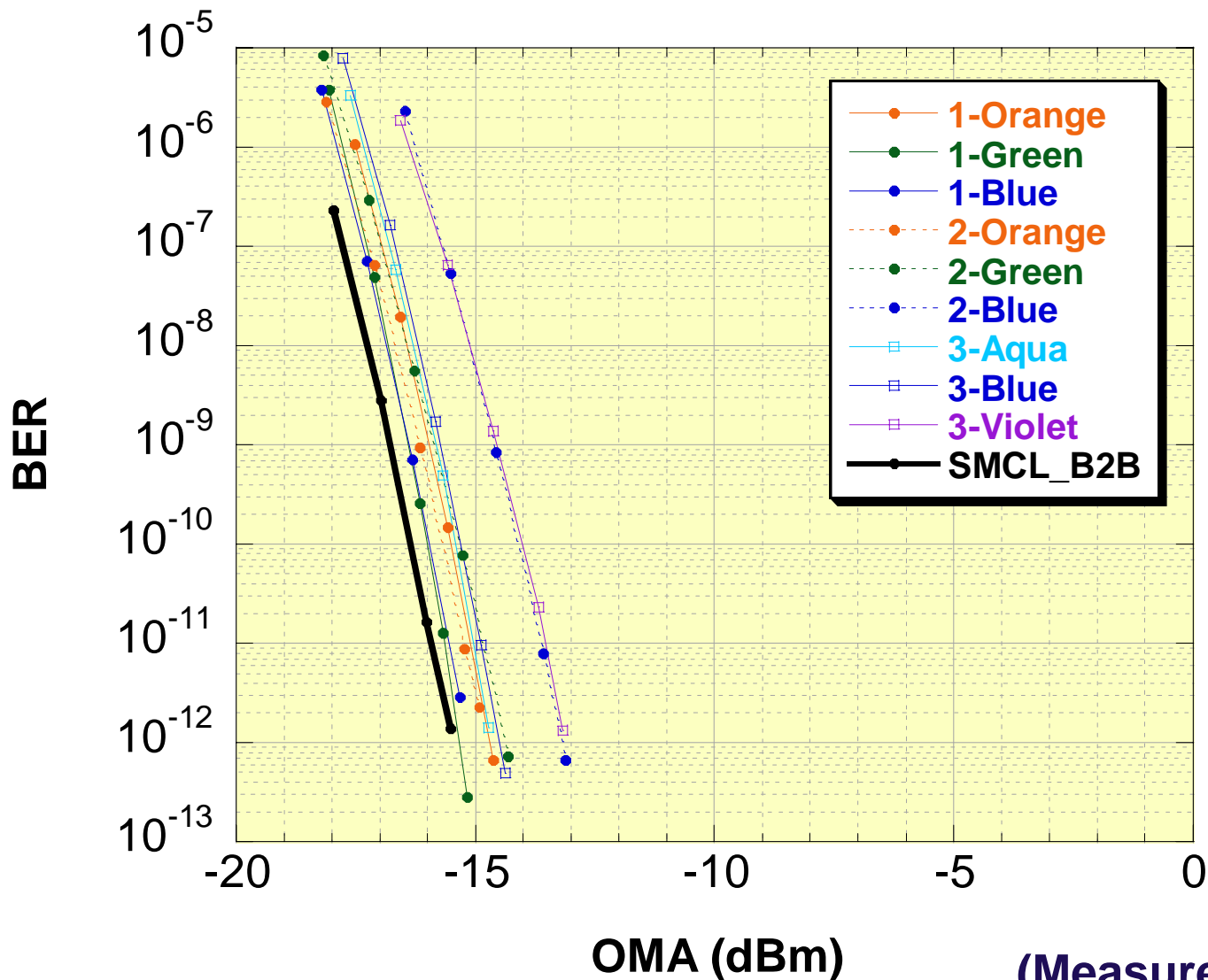

(Measurements made Oct. 2003)

- Measurements made with discrete FFE and DFE IC's
 - Limited dynamic capability for these tests
- Connector off-sets not included, likely to degrade final performance

TIA 12-96 300m MMF Round Robin: OSL Results

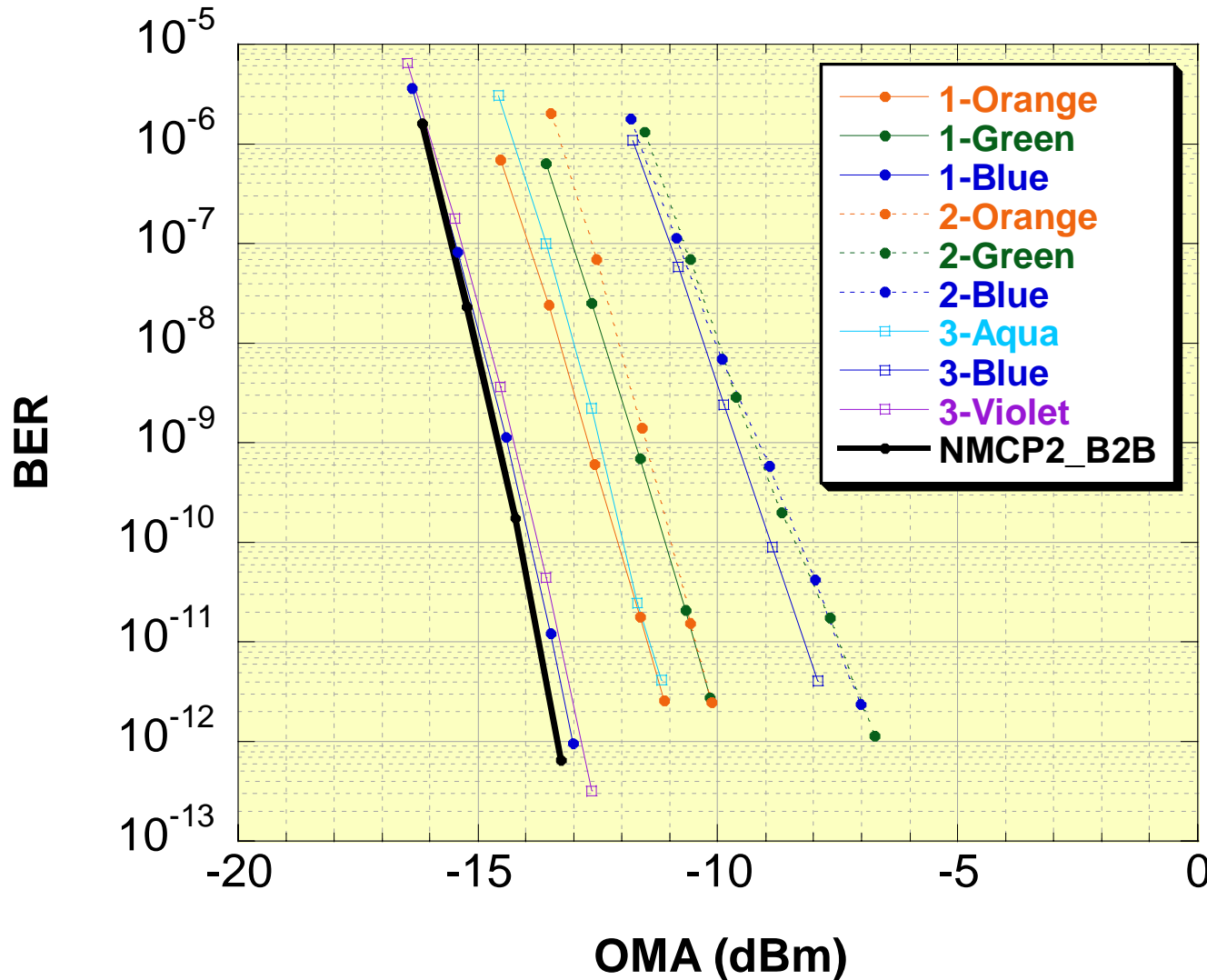

- Measurements made with discrete FFE and DFE IC's
 - Limited dynamic capability for these tests

(Measurements made Oct. 2003)

Discussion & Next Steps

- Simulations
 - DFE architecture required for 300m performance
 - Will repeat with adopted '81 restricted' model & OM1 Monte Carlo model as provided by the channel ad-hoc group
 - Additionally, will need to include connector off-sets
- Experimental
 - 5dB PIE-D budget covered all 300m TIA 12-96 fibres for CL
 - 7.5dB PIE-D budget covered all 300m TIA 12-96 fibres with OSL (in & out of spec fibers)
 - High off-set connectors will impact budget required
 - Likely dependent on launch condition specified
 - BER testing: 6.5-7dB power budget for OSL
 - NB: includes EDC implementation penalty and un-equalized dynamic effects of the 2-chip set-up
 - Additional testing with the agreed connector/channel from the channel ad-hoc sub-task group planned
- Early implementations (circa Q2 2003) demonstrate 300m over FDDI-grade fiber is challenging but possible

Back up

TIA 12-96 Set PIE Metrics for CL and OSL

CL

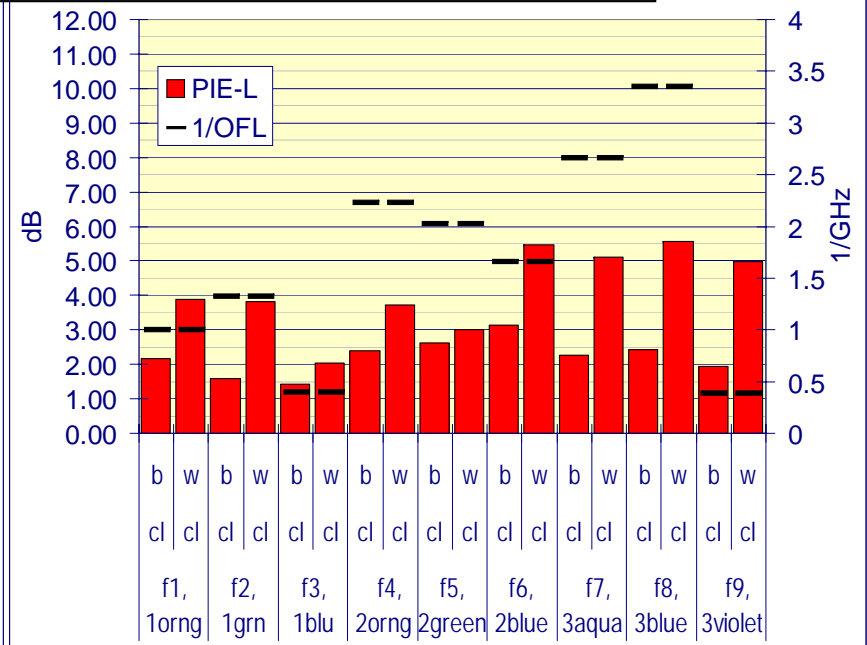
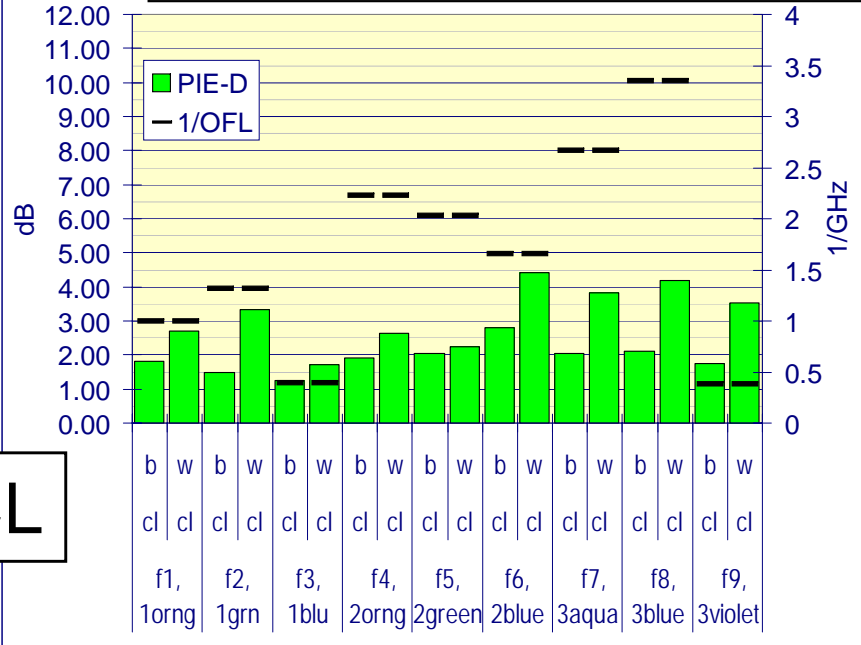

OSL

