

On Comment #445

Pete Cibula

P802.3bq Rx CMNR ad hoc chair

Discussion Topics

- Comment #445, Suggested Remedy and Proposed Response
- D2.0 text for 113.5.4.3 (for reference)
- Proposed Informative Annex
 - Some minor updates based on P802.3bq D2.0, Comments #85 and #246
- Summary and Recommendation

Comment #445

<i>Cl</i> 113	<i>SC</i> 113.5.4.3	<i>P</i> 161	<i>L</i> 32	# 445
Frazier, Howard		Broadcom Corporation		
<i>Comment Type</i>	TR	<i>Comment Status</i>	D	<i>PMA</i>
If the editor's note is correct, then this draft was not ready for WG ballot.				
<i>Suggested Remedy</i>				
If the editor's note is incorrect, then remove it. If the editor's note is correct, then "confirm the source-adjustment criteria, measurement points, and levels used with the clamp methodology in this subclause" and restart the WG ballot.				
<i>Proposed Response</i>		<i>Response Status</i>	W	
PROPOSED ACCEPT IN PRINCIPLE. Remove editor's note.				

P802.3bq D2.0, Subclause 113.5.4.3

113.5.4.3 Rejection of External EM Fields

When the cabling system is subjected to electromagnetic fields, currents are generated in the shield which may be converted to interference. This specification is provided to limit the sensitivity of the PMA receiver to external EM fields picked up by the cabling and interconnect system. It provides an assessment method of the electromagnetic performance of the link segment and the PHY, including the MDI.

An 80 MHz to 2000 MHz test can be made based on the cable clamp test defined in 40.6.1.3.3, a 30 meter plug-terminated Category 8 channel that meets the requirements of 113.7, and suitable broadband ferrites. All components in the test remain over the ground reference plane. A sine wave with the amplitude held constant over the whole frequency range from 80MHz to 2000MHz, with the amplitude calibrated so that the signal power measured at the output of the clamp does not exceed 6dBm, is used to generate the external electromagnetic field and corresponding shield current.

A system integrating a 40GBASE-T PHY may perform this test to evaluate anticipated performance in regulatory test environments. Operational requirements of the transceiver during the test are determined by the manufacturer.

Editor's note (to be removed prior to publication): Commenters are encouraged to confirm the source-adjustment criteria, measurement points, and levels used with the clamp methodology in this subclause.

14
15
16
17
18
19
20
21
22
23
24
25
26
27
28
29
30
31
32
33

Proposed Informative Annex 113A

- As suggested in ad hoc discussions, it is critical that the test conditions be well controlled.
- Clause 40 included Annex 40B to address this issue, and it is (or at least, is believed to be) generally accepted as a good solution to this issue.
- The following Annex 113A is based on Annex 40B, with appropriate updates for 40GBASE-T technology (cable diameter, frequency range) and some potential improvements in the calibration and setup.
 - Source-adjustment criteria, measurement points, and levels used with the clamp methodology in Subclause 113.5.4.3 are defined in this Annex.
 - Other refinements (such as suggested fixtures, limits, alternate distances between the clamp and MDI, etc.) can be easily accommodated as the ad hoc completes additional investigations.
- A mark-up is available for review at the Rx CMNR ad hoc section of the P803.bq project site.
- Proposed Annex 113A text is provided on the following slides

Key Elements of the Annex

- Description of cable clamp and test setup
 - What's in the Annex
 - Description, dimensions and electrical characteristics (IL, RL) of the clamp
- Cable clamp validation
 - Procedure to verify clamp performance
 - Confirm that the induced common-mode and differential-mode noise levels on the cable do not exceed maximum limits
- Test Setup
 - Representative implementation to provide guidance on the test configuration, measurement points and levels

Annex 113A (informative)

Description of cable clamp and test setup

Annex 113A Description of cable clamp and test setup
(informative)

Overview

- This annex describes a cable clamp and a representative methodology that should be used in the rejection of external EM fields test of 113.5.4.3, which is used to determine the sensitivity of the PMA receiver to external EM fields picked up by the cabling and interconnect system.

Description of cable clamp

Description of cable clamp

- As shown in Figure 113A-1 and 113A-2, the clamp is 300 mm long, 75 mm wide, 78 mm high with a center opening of 9.525 mm (0.375 in). The clamp consists of two halves that permit the insertion of a cable into the clamp.
- The clamp has a copper center conductor and an aluminum outer conductor with a high density polyethylene dielectric. The following is a review of the construction and materials of the clamp:
 - a) Inner conductor - Copper tubing with an inner diameter of 9.53 mm (0.375 in) and an outer diameter of 12.7 mm (0.50 in).
 - b) Outer conductor - Aluminum bar that is 300 mm long and approximately 78mm by 75mm. The bar is milled to accept the outer diameter of the dielectric material.
 - c) Dielectric - High Density Polyethylene (Residual, TypeF) with dielectric constant of 2.32. The hollow cylinder has an outside diameter of 45 mm and an inner diameter that accepts the outside diameter of the copper inner conductor.
 - d) Connectors - BNC connectors are located 9 mm (0.39 in) from each end of the clamp and are recessed into the outer conductor. The center conductor of the connector is connected to the inner conductor as shown in Figure 113A-2.
 - e) Clamping screws - Six screws are used to connect the two halves of the clamp together after the cable has been inserted. Although clamping screws are shown in Figure 113A-1, any clamping method may be used that ensures the two halves are connected electrically and permits quick assembly and disassembly.
 - f) Nylon screws - Used to align and secure the inner conductor and dielectric to the outer conductor. The use and location of the screws is left to the manufacturer.
 - g) Keying bolts - Two studs used to align the two halves of the clamp.
- As shown in Figure 113A-2 the inner conductor on the bottom half of the clamp extends slightly (~ 0.1mm) above the dielectric to ensure there is good electrical connection with the inner conductor of the top half of the clamp along the full length of the conductor when the two halves are clamped together.
- The electrical parameters of the clamp between 80MHz and 2GHz are as follows:
 - a) Insertion loss: <5 dB
 - b) Return loss: >20.0 dB (80MHz-520MHz), $20.5 - 50\log_{30}(f/500)$ dB (520MHz-2000MHz)

Cable Clamp Construction

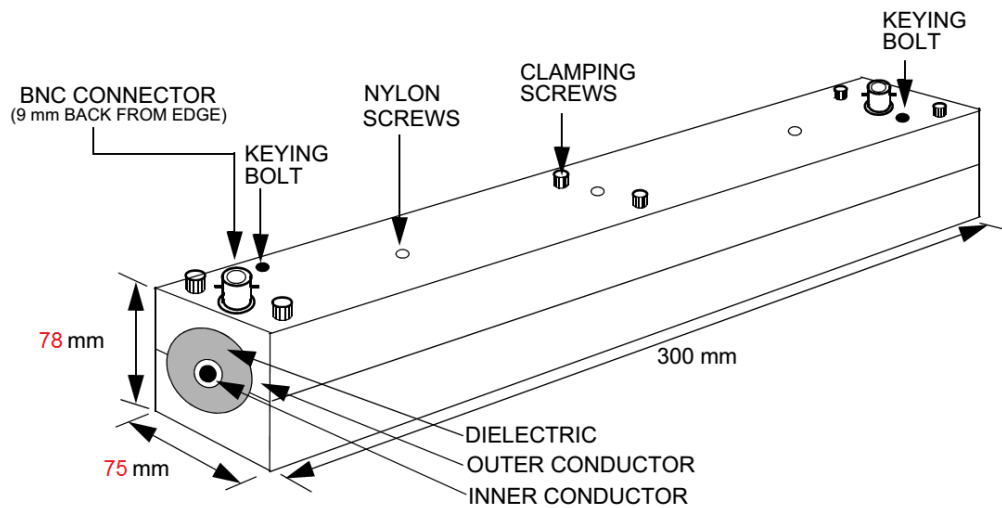

Figure 113A-1 - Cable clamp

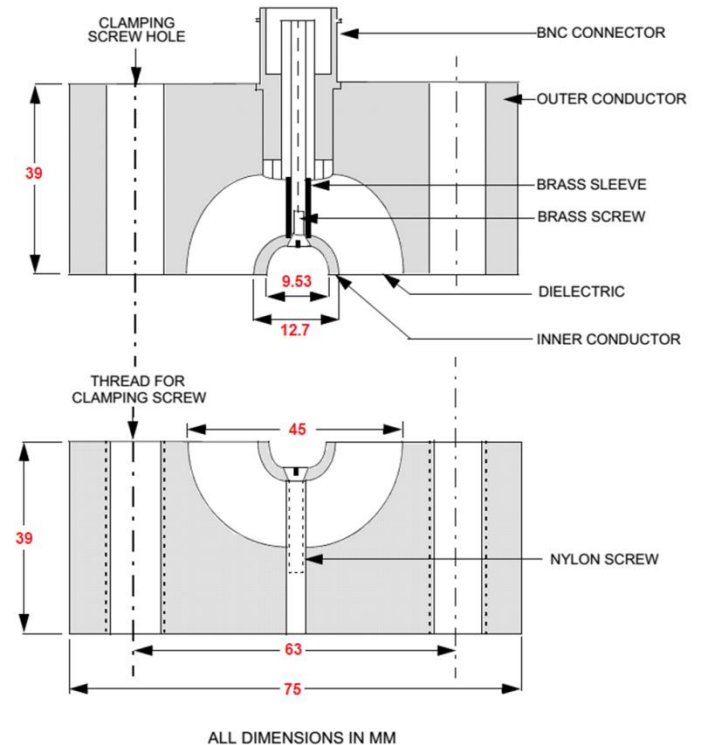

Figure 113A-2 - Cross-section of cable clamp

Annex 113A.1 Cable clamp validation (1)

- In order to ensure the cable clamp described above is operating correctly, the following test procedure is provided. Prior to conducting the following test shown in Figure 113A-3, the clamp should be tested to ensure the insertion loss and return loss are as specified above. The cable clamp validation test procedure uses a well-balanced 4-pair, ~~Category 8 test cable or better that meets the specifications of 113.7~~ **plug-terminated channel that meets the requirements of 113.7.**
- The test hardware consists of the following:
 - a) Transmitter/Receiver – A link partner system, configured for the data rate being evaluated, with the transmitter disabled.
 - b) Breakout Fixture – A passive fixture with a modular jack input and individual outputs for each of the 8 signal wires. Wires of pairs not being measured should be terminated to the ground plane with a 50 Ω resistor.
 - c) Balun - 3 ports, laboratory quality with a 100 Ω differential input and a 50 Ω single-ended, unbalanced output:
 - Insertion Loss (100 Ω balanced <-> 50 Ω unbalanced): <4dB (1MHz-3GHz)
 - Return Loss: >30dB (1MHz-3GHz)
 - Common-Mode Rejection: >60dB (1MHz-200MHz), >30dB at 3GHz
 - d) Test cable - 4-pair 100 Ω S/FTP Category 8 balanced cable at least 30 m long.
 - e) Chokes (5) - Wideband Ferrite Material:
 - Inner diameter: 8.7 mm to 10.15mm
 - Impedance: 175 Ω @ 100 MHz, 275 Ω @ 250 MHz, 375 Ω @ 500 MHz, 400 Ω @ 1000 MHz
 - f) Ground plane - Copper sheet or equivalent.
 - g) Signal generator
 - h) Signal Sensor & Measurement System - Oscilloscope, power meter or spectrum analyzer
 - i) Receiver

Annex 113A.1 Cable clamp validation (2)

- With the test cable inserted in the cable clamp, a signal generator with a 50 Ω output impedance is connected to one end of the cable clamp and a signal sensor with a 50 Ω input impedance is connected to the other end. The signal generator shall be capable of providing a sine wave signal of 80 MHz to 2GHz. The output of the signal generator is adjusted for a signal power of 6dBm at 80 MHz on the signal sensor. The remainder of the test is conducted without changing the signal generator voltage. The cable pairs not connected to the balun are terminated in a resistor network. It is very important that the cable clamp, breakout fixture and balun have good contact with the ground plane. The chokes, which are located next to each other, are located approximately 2.0 cm from the clamp. The cable between the clamp and the balun should be straight and not in contact with the ground plane.
- The differential-mode and common-mode voltage outputs of the balun and breakout fixture should meet the limits shown in Table 113A-1 over the frequency range 80 MHz to 2GHz for each cable pair.
- NOTE - Prior to conducting the validation test the cable clamp should be tested without the cable inserted to determine the variation of the signal generator voltage with frequency at the output of the clamp. The signal generator voltage should be adjusted to 6dBm at 80 MHz on the signal sensor. When the frequency is varied from 80MHz to 2GHz, the measured power should not vary more than $\pm 10\%$. If the power varies more than $\pm 10\%$, then a correction factor must be applied at each measurement frequency.

Annex 113A.1 Cable clamp validation (3)

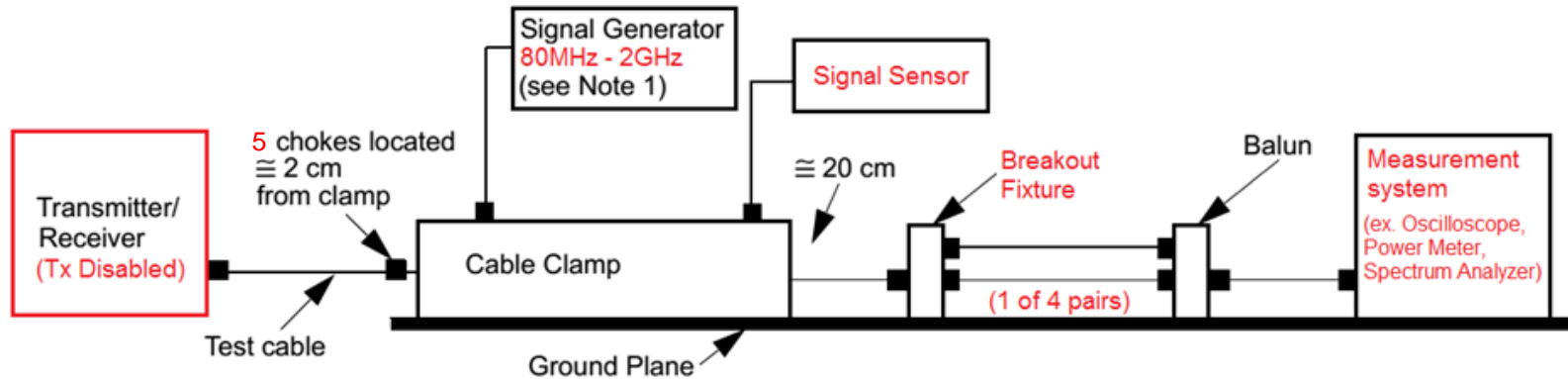

Figure 113A-3 - Cable clamp validation test configuration

Table 113A-1 - Common- and differential-mode output voltages

Frequency (f)	Common-mode voltage	Differential-mode voltage
80-250 MHz	$1.07 - 0.6 (f-80)/170 V_{pp}$	$22 mV_{pp} (-29 dBm)$
250MHz-2GHz	$470mV_{pp} (-2.6dBm)$	$22mV_{pp}$

Annex 113A.2 Test Setup

- An up to 30-meter, 4-pair ~~Category 8~~ channel that meets the specification of 113.7 is connected between two 40GBASE-T PHYs and inserted into the cable clamp. The cable should be terminated on each end with an MDI connector plug specified in 113.8.1. The clamp should be located a distance of ~20 cm from the receiver. It is recommended that the cable between the transmitter and the cable clamp be installed either in a linear run or wrapped randomly on a cable rack. The cable rack should be at least 3 m from the cable clamp. In addition, the cable clamp and 40GBASE-T receiver should be placed on a common ground plane and the ground of the receiver should be in contact with the ground plane. The chassis grounds of all test equipment used should be connected to the ground plane. No connection is required between the ground plane and an external reference. A signal generator with a 50Ω impedance is connected to one end of the clamp and measurement equipment with a 50Ω input is connected to the other end of the clamp. The signal generator shall be capable of providing a sine wave signal of 80 MHz to 2 GHz. The output of the signal generator is adjusted for a signal power not to exceed 6 dBm at the signal sensor to simulate an external electromagnetic field of approximately 3 V/m.

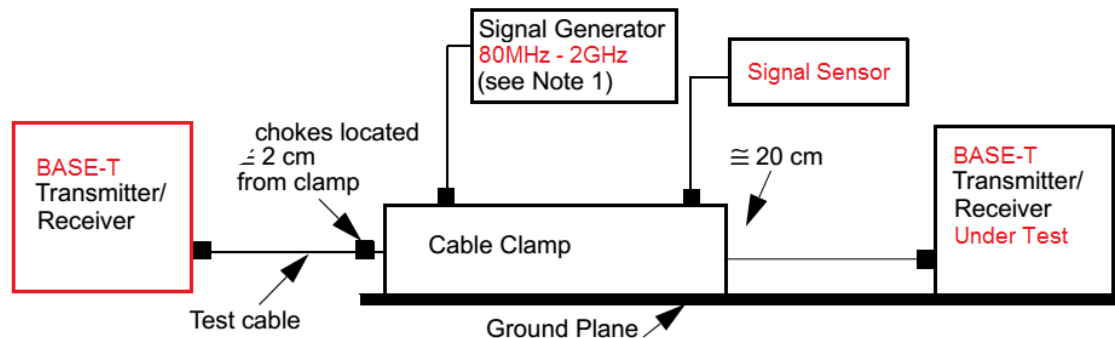

Figure 113A-4 - Cable clamp test configuration

Summary & Recommendation

Summary

- This contribution presents an informative Annex (Annex 113A) to support Subclause 113.5.4.3
 - The purpose of such an Annex is to provide guidance for implementers wishing to evaluate PHY rejection of external EM fields.
 - The proposed Annex (modeled after Annex 40B) provides helpful information on source-adjustment criteria, measurement points, and levels used with the clamp methodology in a manner that is consistent with previous standards.

Recommendation

- Remove the Editor's Note
- Include the proposed text as an informative Annex
- Update 113.5.4.3 to reference the informative Annex

Thank You!

Changes to 113.5.4.3

113.5.4.3 Rejection of External EM Fields

When the cabling system is subjected to electromagnetic fields, currents are generated in the shield which may be converted to interference. This specification is provided to limit the sensitivity of the PMA receiver to external EM fields picked up by the cabling and interconnect system. It provides an assessment method of the electromagnetic performance of the link segment and the PHY, including the MDI.

An 80 MHz to 2000 MHz test can be made based on the cable clamp test **described in Annex 113A** ~~defined in 40.6.1.3.3~~, a 30 meter plug-terminated ~~Category 8~~ channel that meets the requirements of 113.7, and suitable broadband ferrites. All components in the test remain over the ground reference plane. A sine wave with the amplitude held constant over the whole frequency range from 80MHz to 2000MHz, with the amplitude calibrated so that the signal power measured at the output of the clamp does not exceed 6dBm, is used to generate the external electromagnetic field and corresponding shield current.

A system integrating a 40GBASE-T PHY may perform this test to evaluate anticipated performance in regulatory test environments. Operational requirements of the transceiver during the test are determined by the manufacturer.

~~Editor's note (to be removed prior to publication): Commenters are encouraged to confirm the source-adjustment criteria, measurement points, and levels used with the clamp methodology in this subclause.~~

1000BASE-T Clamp IL & RL

- Electrical specifications in Annex 40B include insertion loss and return loss
 - IL < 0.2dB, RL > 20dB
- Plots show the measured response of an Annex 40B-compliant 1000BASE-T clamp (from 2001)

Insertion loss (1MHz – 250MHz)

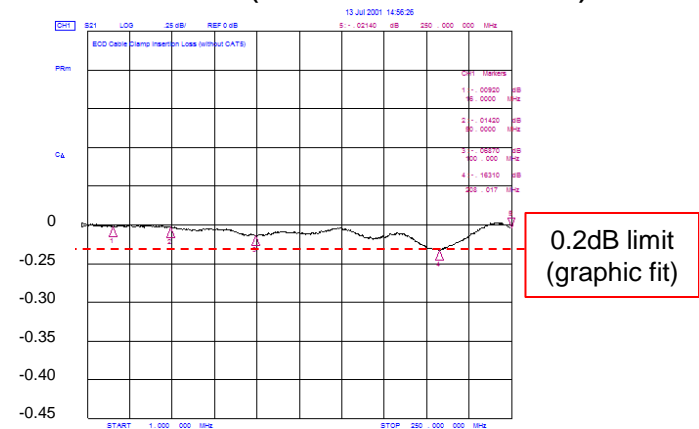

Return loss (1MHz – 250MHz)

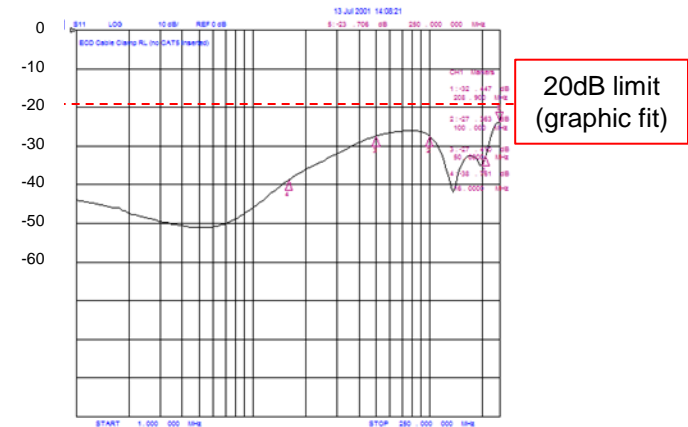

“New” Clamp IL & RL

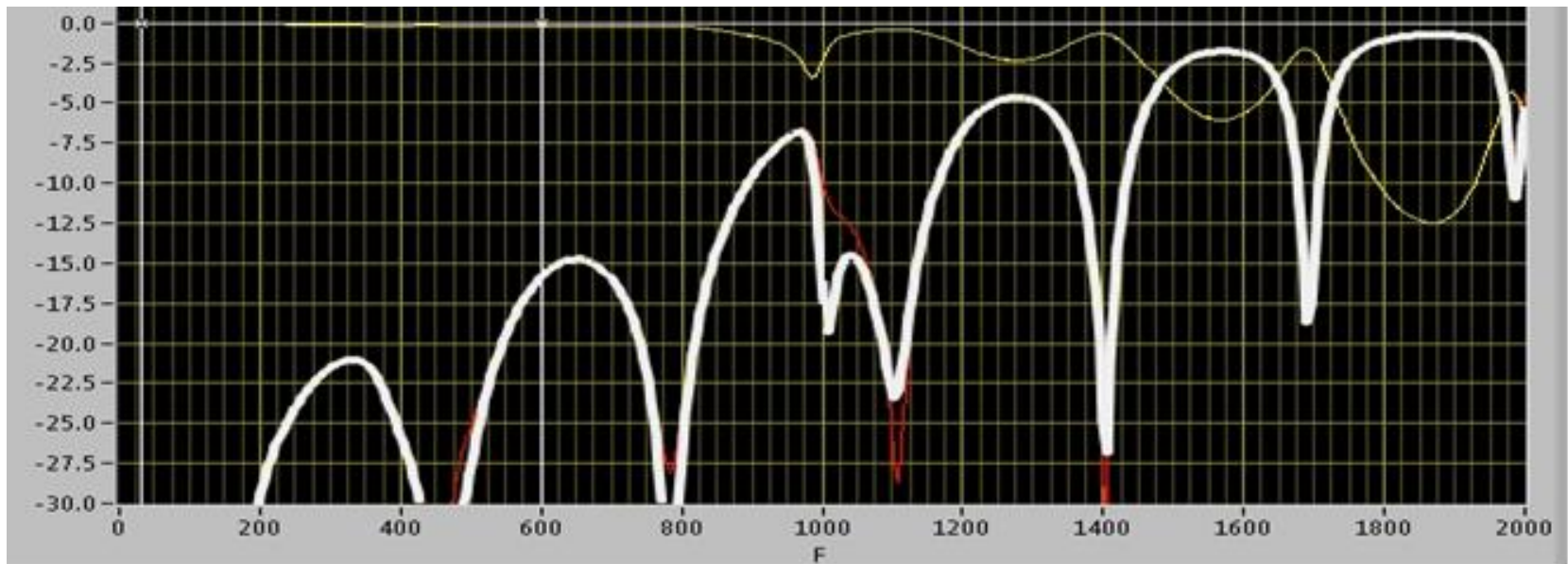

Measurement provided by Bryan Moffitt, Commscope

Proposed “New” Clamp RL Limit

CC102 REV B - S/N CC109-006 Return Loss (600MHz - 2GHz shown)

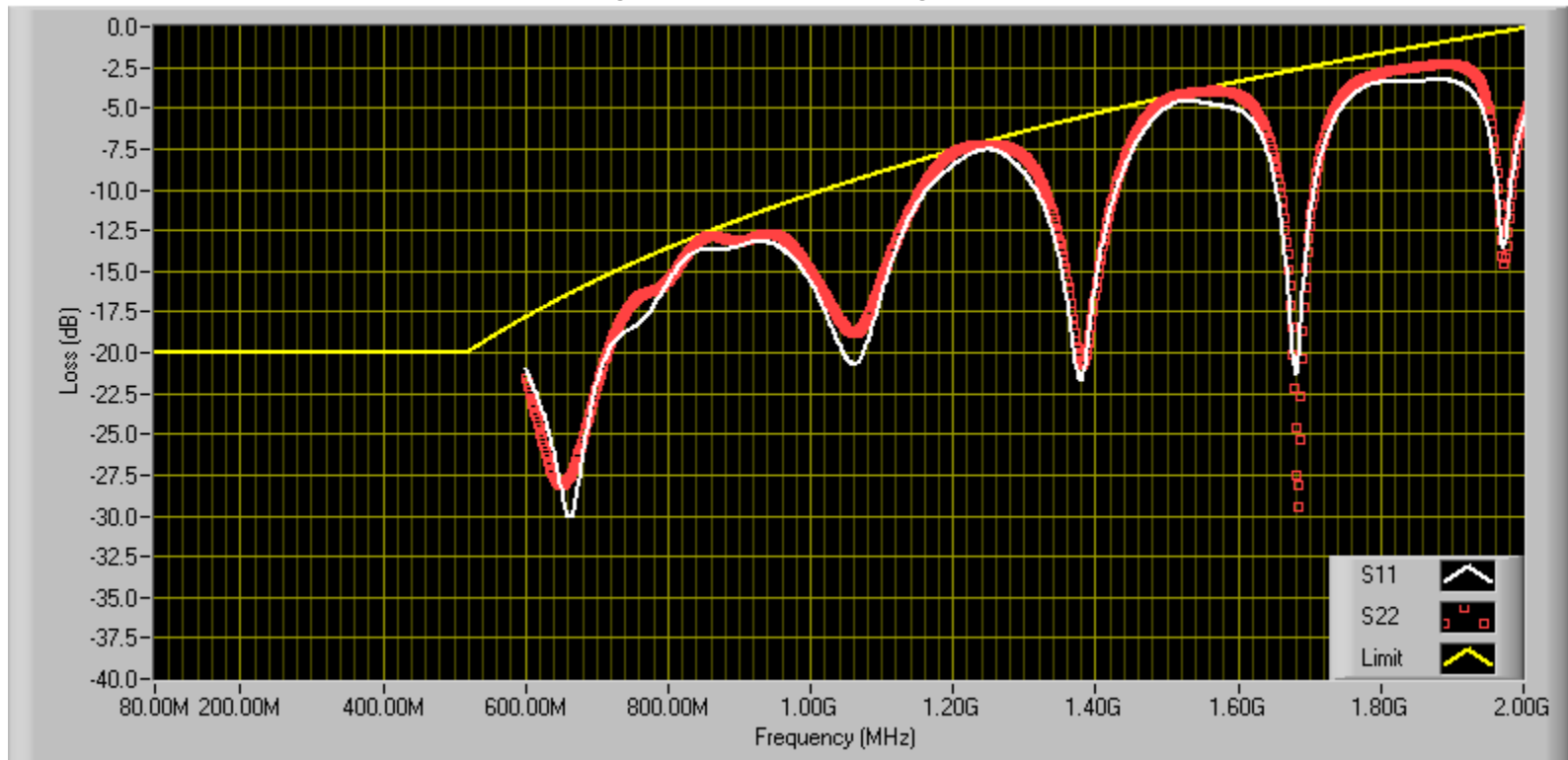

Measurement provided by Pete Cibula, Intel Corporation

CM and DM Limits

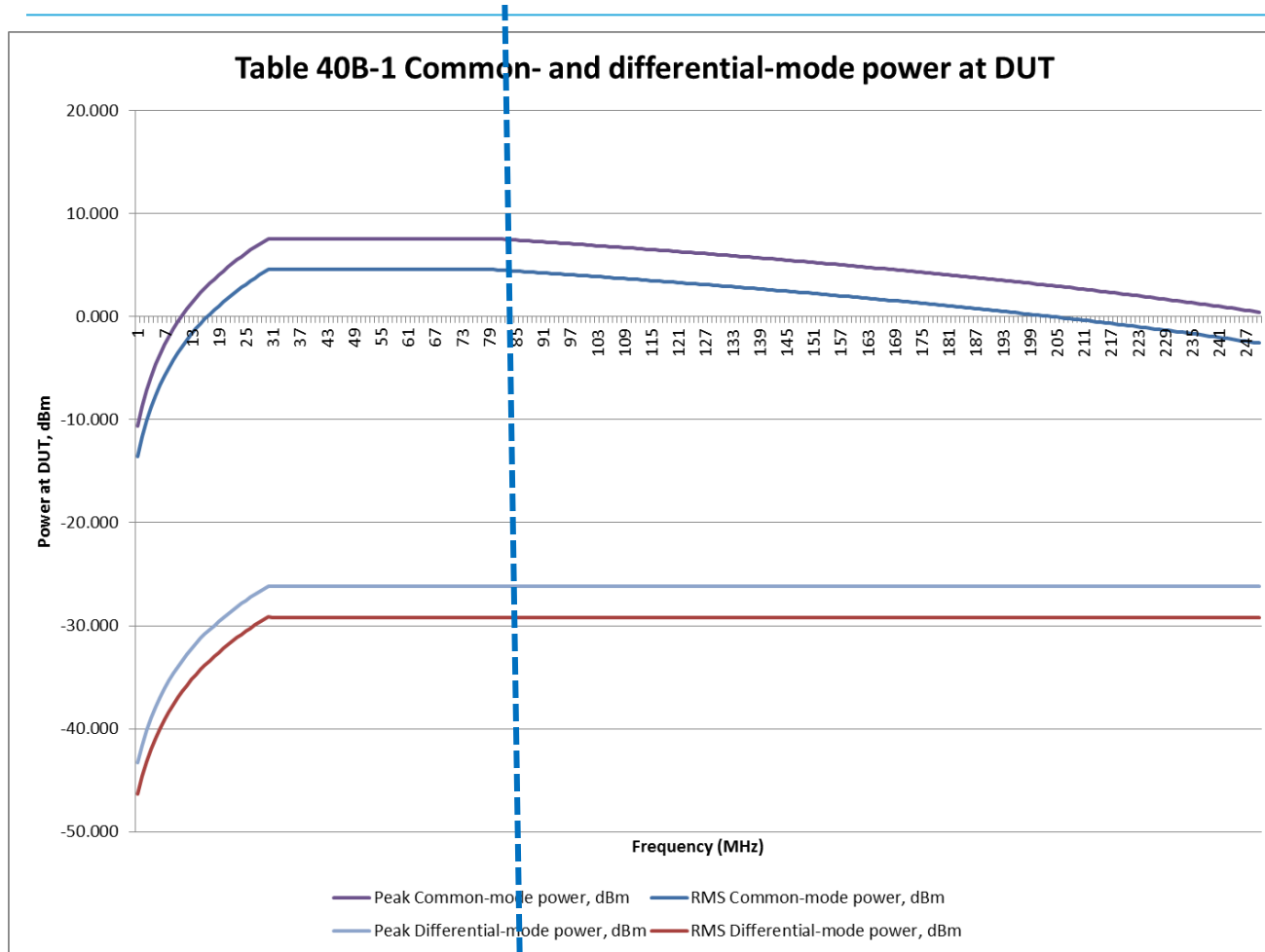

Extend 250MHz values to 2GHz for 40GBASE-T



80MHz (Clause 55 & Clause 113 start)