

Discussion of Text for 40GBASE-T Common-Mode Noise Rejection

Pete Cibula, Intel Corporation

Discussion Points

- Look at some language using the IEEE-SA Standards Style Manual
 - The *lingua franca* for 802.3 standards 😊
- Look at our starting point(s)
 - 10GBASE-T Subclause 55.5.4.3 (now)
 - 1000BASE-T Subclause 40.6.1.3.3 (follow-up)
- Break down our starting point to try and see what it *really* means
- Suggest some proposed text for the corresponding 40GBASE-T specification
- Identify related next steps for the Rx CMNR ad hoc

Normative or Informative?

- From the 2014 IEEE-SA Standards Style Manual
 - **Normative text** is information that is required to implement the standard and is therefore **officially part of** the standard.
 - **Informative text** is provided for information only and is therefore not **officially part of** the standard.

Normative text

- Normative text (information required to implement the standard) includes the following:
 - The main clauses of the documents including figures, tables, and equations
 - Footnotes to tables
 - Footnotes to figures
 - Annexes marked “(normative)”

Informative text

- Informative text (text provided for information only) includes the following:
 - Frontmatter
 - Notes to text, tables, and figures
 - At the first instance of a note associated with text, a table, or a figure, the following should appear:
 - NOTE—Notes to text, tables, and figures are for information only and do not contain requirements needed to implement the standard.
 - Annexes marked “(informative),” e.g., Bibliography

Word Usage

- *shall* indicates mandatory requirements strictly to be followed in order to conform to the standard and from which no deviation is permitted
 - *shall* equals *is required to*
- *should* indicates that among several possibilities, one is recommended as particularly suitable without mentioning or excluding others; or that a certain course of action is preferred but not necessarily required
 - *should* equals *is recommended that*
- *may* is used to indicate a course of action permissible within the limits of the standard
 - *may* equals *is permitted to*
- *can* is used for statements of possibility and capability, whether material, physical, or causal
 - *can* equals *is able to*

10GBASE-T Clause 55

55.5.4.3 Common-mode noise rejection

- This specification is provided to limit the sensitivity of the PMA receiver to common-mode noise from the cabling system. Common-mode noise generally results when the cabling system is subjected to electromagnetic fields.
- The common-mode noise can be simulated using the cable clamp test defined in 40.6.1.3.3. A 6 dBm sine wave signal from 80 MHz to 1000 MHz can be used to simulate an external electromagnetic field. Operational requirements of the transceiver during the test are determined by the manufacturer. A system integrating a 10GBASE-T PHY may perform this test.

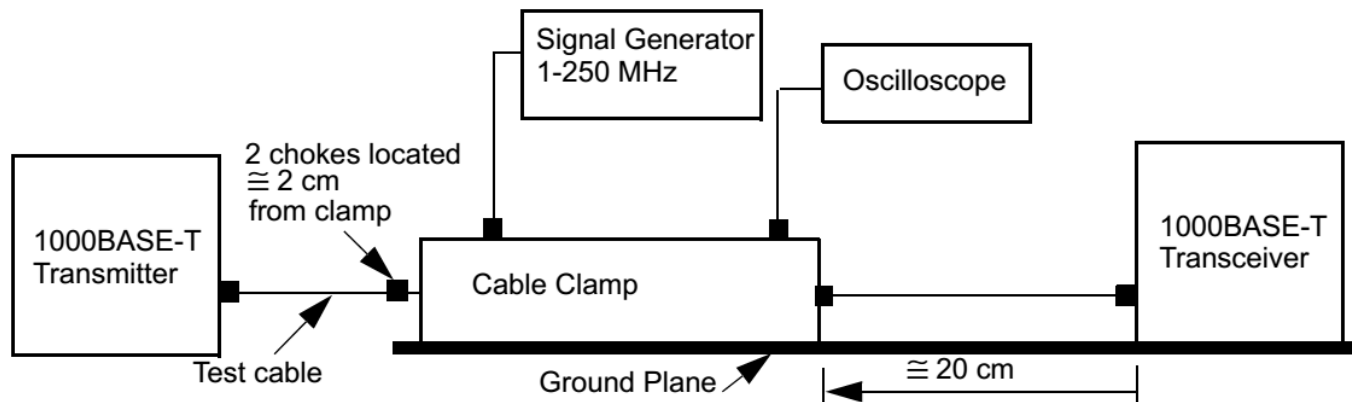

Figure 40–28—Receiver common-mode noise rejection test

Note: Figure is from 40.6.1.3.3

What We Have Now For 10GBASE-T (1/5)

- The text in 55.5.4.3 is in the standard = Normative
 - Meaning, “it” – specifically, a specification for receiver common-mode noise rejection - is required to implement the standard and is therefore officially part of the standard.
- Paragraph #1, all: *This specification is provided to limit the sensitivity of the PMA receiver to common-mode noise from the cabling system. Common-mode noise generally results when the cabling system is subjected to electromagnetic fields.*
 - Identifies a specification for receiver common-mode noise rejection and provides some indication as to the source of the noise

What We Have Now For 10GBASE-T (2/5)

- Paragraph #2 Sentence #1: *The common-mode noise can be simulated using the cable clamp test defined in 40.6.1.3.3.*
 - *can* is used for statements of possibility and capability, whether material, physical, or causal; “*is able to*”
 - It is possible to use the cable clamp to simulate common-mode noise that results when the cabling system is subjected to electromagnetic fields
 - **However**, the cable clamp test defined in 40.6.1.3.3 is not appropriately specified for 10GBASE-T technology (and by extension, 40GBASE-T)

What We Have Now For 10GBASE-T (3/5)

- Paragraph #2 Sentence #2: *A 6 dBm sine wave signal from 80 MHz to 1000 MHz can be used to simulate an external electromagnetic field.*
 - *can* is used again, so:
 - It is possible to simulate the external electromagnetic field with a 6 dBm sine wave signal ranging from 80 MHz to 1000 MHz.
- Some observations
 - The origin of the 6 dBm power level is (as far as I know) unknown at this time. Is this for an external 3V/m field? 10V/m field? Other?
 - The frequency range aligns with IEC 61000-4-3, Clause 5.1 Test levels related to general purposes
 - “The tests are normally performed without gaps in the frequency range 80 MHz to 1 000 MHz.”

What We Have Now For 10GBASE-T (4/5)

- Paragraph #2 Sentence #3: *Operational requirements of the transceiver during the test are determined by the manufacturer.*
- Some thoughts on this statement
 - What are our/industry assumptions about the manufacturer?
 - If it's the **PHY** manufacturer, they get to define their own Rx CMNR limits 😊
 - If it's the **port** manufacturer, the flexibility has some disadvantages for both PHY manufacturers and system implementers in the form of potential variability in product performance and potentially interoperability 😞
 - Are there common high-level performance requirements that could be used to clarify this (believed to be intentional) softness in the operational requirements?

What We Have Now For 10GBASE-T (5/5)

- Paragraph #2 Sentence #4: *A system integrating a 10GBASE-T PHY may perform this test.*
 - *may* is used to indicate a course of action permissible within the limits of the standard; “*is permitted to*”
- Observations
 - It is permitted to perform this test on a system integrating a 10GBASE-T PHY.
 - It isn't required but isn't prohibited.

So, what is 55.5.4.3 saying?

- This is a specification for receiver common-mode noise rejection that is officially part of the standard.
- The specification is provided to limit the receiver sensitivity to common-mode noise that is coupled onto the cable from external electromagnetic fields.
- It is possible to use the specified cable clamp to simulate this common-mode noise, using a 6 dBm sine wave signal ranging from 80 MHz to 1000 MHz to simulate the external electromagnetic field.
- The manufacturer (of a port) determines the operational requirements in this test environment.
- It is possible (but not required) for a system using a 10GBASE-T PHY to perform this test (against the operational requirements determined by the manufacturer).

Some thoughts on the specification

- It is probably a good idea to keep a specification for receiver common-mode noise rejection in the standard
 - Improved cabling should provide improved noise rejection, as suggested in recent studies ([pischl_3bq_01b_1014.pdf](#), [cibula_3bq_02a_1114.pdf](#))
 - However, shield/screen integrity may vary and result in some (TBD) level of common-mode noise coupling ([CMNRadhocSchicketanz-2.pdf](#))
- There are a few areas that may benefit from some updates/changes
 - Better definition of the impairment level – limits on common-mode and resultant differential-noise, similar to those in Annex 40B
 - Better description/definition of operational requirements
 - Correct definition of the clamp and clamp setup (Annex 40B) for new cabling, etc.
- Others? For further discussion...

Notes on the Strawman Text

- A hybrid of Clause 40.5.4.3 (1000BASE-T) and Clause 55.5.4.3 (10GBASE-T) that is intended to improve the current text
 - Provide guidance regarding the purpose and intent of the subclause
 - Provide sufficient detail to help implementers evaluate the performance of a system incorporating 40GBASE-T technology to common-mode impairments
 - Provide an appropriate informational annex with required updates and useful (TBD) enhancements

40GBASE-T Clause 105.5.4.3 Strawman

105.5.4.3 Common-mode noise rejection

- This specification is provided to limit the sensitivity of the PMA receiver to common-mode noise from the cabling system. Common-mode noise generally results when the cabling system is subjected to electromagnetic fields.
- The common-mode noise can be simulated using a cable clamp test method. A **TBD** dBm sine wave signal from 80 MHz to 1000 MHz (**TBD**) resulting in a maximum common-mode noise of **TBD** and corresponding differential-mode noise of **TBD** at the MDI can be used to simulate an external electromagnetic field. A description of the cable clamp, as well as the validation procedure, can be found in Annex (**TBD**).
- Operational requirements of the transceiver during the test are determined by the manufacturer. This test may be performed on a system integrating a 40GBASE-T PHY to evaluate the anticipated performance in regulatory test environments. *Editorial note – Can/should we better define operational requirements, similar to IEC 61000-4-3 2006, or relate them to MICE E1/E2/E3?)*

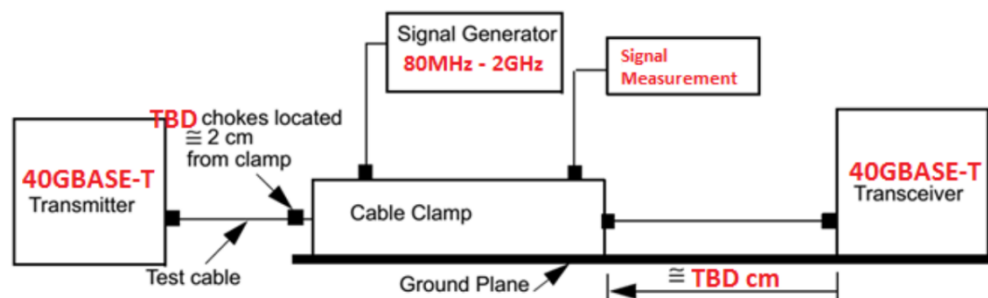

Figure TBD —Receiver common-mode noise rejection test

Potential Paths Forward

Work by ad hoc participants to define the following

- Relationship/correlation between the Rx CMNR test and system immunity requirements
 - Work is underway using 10GBASE-T PHYs and unshielded and shielded cabling
- Operational requirements
 - No activity at this time – an opportunity!
- Updates to existing and/or alternative test methods, including fixture calibration techniques and noise limits
 - Effectiveness and applicability of the method for shielded cabling
 - Some investigations showing resulting differential noise power at the MDI & PHY; more to come
 - Capabilities/limitations of clamp noise coupling techniques over an extended frequency range (80MHz – 2GHz)
 - Some investigations showing that a constant power level can be achieved at the “DUT” end of the clamp and that noise can be coupled over this range; concerns around 1GHz
 - Alternative methods
 - Some discussion of a diagnostic vs. functional test and chamber-based methods

Request continued work in “green” areas & develop operational requirements

Thank You!

More 1000BASE-T background, summary of operational requirements for regulatory tests, and rough markups of Annex 40B

BACKUP

Some origins of the 1000BASE-T clamp test and performance criteria

- Cable clamp test method
 - See “An Improved Common Mode Noise Tolerance Test for 1000BASE-T” ([Luc Adriaenssens, 1998](#))
- Receiver performance requirements for 1000BASE-T
 - See 100BASE-T4, Clause 23.5.1.3.4 and 100BASE-T2, Clause 32.6.1.3.6 Common-mode rejection
 - “While receiving packets from a compliant 100BASE-T4 transmitter connected to all MDI pins, *a receiver shall send the proper PMA UNITDATA.indication messages to the PCS* for any differential input signal E_s that results in a signal E_{dif} that meets 23.5.1.3.1 even in the presence of common-mode voltages E_{cm} .”
 - E_{dif} is from a source E_s (transmitter) after a worst-case UTP model or a connection less than 1m, and E_{cm} is comparable to 10BASE-T (500kHz, 25Vpk-pk square wave)

Evaluation of Test Results per IEC 61000-4-3 2006

Results are classified in terms of the loss of function or degradation of performance of the equipment under test (EUT) relative to a defined performance level.

Four classifications are defined:

- a) Normal performance within limits specified by the manufacturer, requestor or purchaser
- b) Temporary loss of function or degradation of performance
 - Ceases after the disturbance ceases
 - EUT recovers normal performance without operator intervention
- c) Temporary loss of function or degradation of performance
 - Requires operator intervention to correct
- d) Loss of function or degradation of performance which is not recoverable
 - Damage to hardware or software, or loss of data

The manufacturer's specification may define effects on the EUT which may be considered insignificant, and therefore acceptable.

Evaluation of Test Results per EN 55024:2010

The manufacturer defines performance criteria in terms which relate to the performance of his specific product when used as intended.

Some examples of functions to be evaluated include essential operational modes and states, peripheral access, software execution, data display and transmission, and speech transmission.

The manufacturer is obligated to express performance criteria in terms which relate to the performance of the product when used as intended. Three performance criteria are applicable:

- Performance criterion A - During and after the test the EUT shall continue to operate as intended without operator intervention. A minimum acceptable performance level is specified by the manufacturer; some defined loss of performance is permitted.
- Performance criterion B - After the test, the EUT shall continue to operate as intended without operator intervention. Degradation of performance is allowed during the test; however, no change of operating state or stored data is allowed to persist after the test.
- Performance criterion C - A temporary loss of function is allowed during and after testing, provided the function is self-recoverable, or can be restored with user controls or by power cycling.

Particular and normative performance criteria for Local Area Networks (LAN) are defined in Annex C.

Evaluation of Test Results per EN 55024:2010 – LAN Equipment

Test conditions

- The minimum test configuration is two pieces of terminal equipment interconnected with manufacturer specified cabling.
- The systems send and receive data at the specified nominal transmission rate while executing a program which exercises the LAN functions.

Particular performance criteria

- Performance criterion A - During and after the test, the EUT shall operate without
 - Exceeding error rates, number of retry requests, or (minimum) data transmission rates beyond manufacturer-defined limits.
 - Protocol failure or loss of link.
- Performance criterion B - Error rates, retry requests and data transmission rates may be degraded during the test.
 - Degradation of Performance criterion A is permitted as long as the EUT self-recovers to normal operating conditions.
 - Operator action is permitted to re-initiate an operation.
- Performance criterion C - During testing degradation of Performance criteria A and B is permitted as long as EUT self-recovers to normal operating conditions or can be restored after the test by the operator.

Annex 105x.1 Description of Cable Clamp Test Method

- An up to 30-meter, 4-pair Category 8 cable that meets the specifications of 105.7 is connected between two 40GBASE-T PHYs and inserted into the cable clamp. The cable should be terminated on each end with an MDI connector plug specified in 105.8.1. The clamp should be located a distance of ~20 TBD cm from the receiver. It is recommended that the cable between the transmitter and the cable clamp be installed either in a linear run or wrapped randomly on a cable rack. The cable rack should be at least 30 cm from the cable clamp. In addition, the cable clamp and 40GBASE-T receiver should be mounted on a common copper or aluminum ground plane and the ground of the receiver should be in contact with the ground plane. The chassis grounds of all test equipment used should be connected to the ground plane. No connection is required between the ground plane and an external reference. A signal generator with a 50Ω impedance is connected to one end of the clamp. Measurement equipment with a 50Ω input is connected to the other end of the clamp. The signal generator shall be capable of providing a sine wave signal of 80 MHz to 2 GHz. The output of the signal generator is adjusted for a signal power of TBD dBm. The measurement equipment to simulate an external electromagnetic field of TBD V/m.

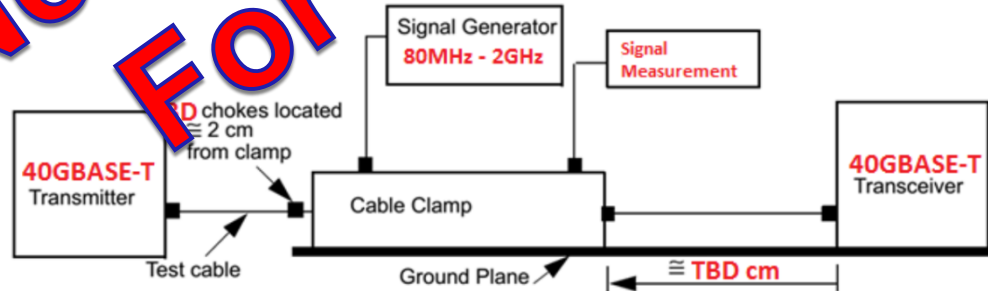

Figure TBD —Receiver common-mode noise rejection test

Annex 105x.1 – Description of Cable Clamp

- This annex describes the cable clamp used in the common-mode noise rejection test procedure 105.5.4.3, which is used to determine the sensitivity of the 40GBASE-T receiver to common-mode noise from the link segment. As shown in Figure 105x-1, the clamp is 300 mm long, 58 mm wide, 54 mm high with a cable opening of ~~6.35 mm (0.25 in)~~. The clamp consists of two halves that permit the insertion of a cable into the clamp.
- The clamp has a copper center conductor and an aluminum outer conductor with a high density polyethylene dielectric. The following is a review of the construction and materials of the clamp:
 - a) Inner conductor - Copper tubing with an inner diameter of ~~5 mm (0.25 in)~~ and an outer diameter of ~~9.4 mm (0.37 in)~~.
 - b) Outer conductor - Aluminum bar that is 300 mm long and approximately 54 mm by 6 mm. The bar is milled to accept the outer diameter of the dielectric material.
 - c) Dielectric - High Density Polyethylene (Resinul, Type F) with dielectric constant of 2.32. An outside diameter of ~~33.5 mm~~ and an inner diameter that accepts the outside diameter of the copper inner conductor.
 - d) Connectors - BNC connectors are located 5 mm (0.39 in) from each end of the clamp and are recessed into the outer conductor. The center conductor of the connector is connected to the center (sic) conductor as shown in Figure 105x-2.
 - e) Clamping screws - Six screws are used to connect the two halves of the clamp together after the cable has been inserted. Although clamping screws are shown in Figure 105x-1, any clamping method may be used that ensures the two halves are connected electrically and permits quick assembly and disassembly.
 - f) Nylon screws - Used to align and secure the inner conductor and dielectric to the outer conductor. The use and location of the screws is left to the manufacturer.
 - g) Key pins - Two studs used to align the two halves of the clamp.
- As shown in Figure 105x-1, the inner conductor on the bottom half of the clamp extends slightly (~ 0.1 mm) above the dielectric to ensure there is good electrical connection with the inner conductor of the top half of the clamp along the full length of the conductor when the two halves are clamped together.
- The electrical parameters of the clamp between 80MHz and 2GHz are as follows:
 - a) Insertion loss: ~~<0.2 dB~~
 - b) Return loss: ~~>20.0 dB~~

Needs to be revised for thicker cable

Cable Clamp Construction

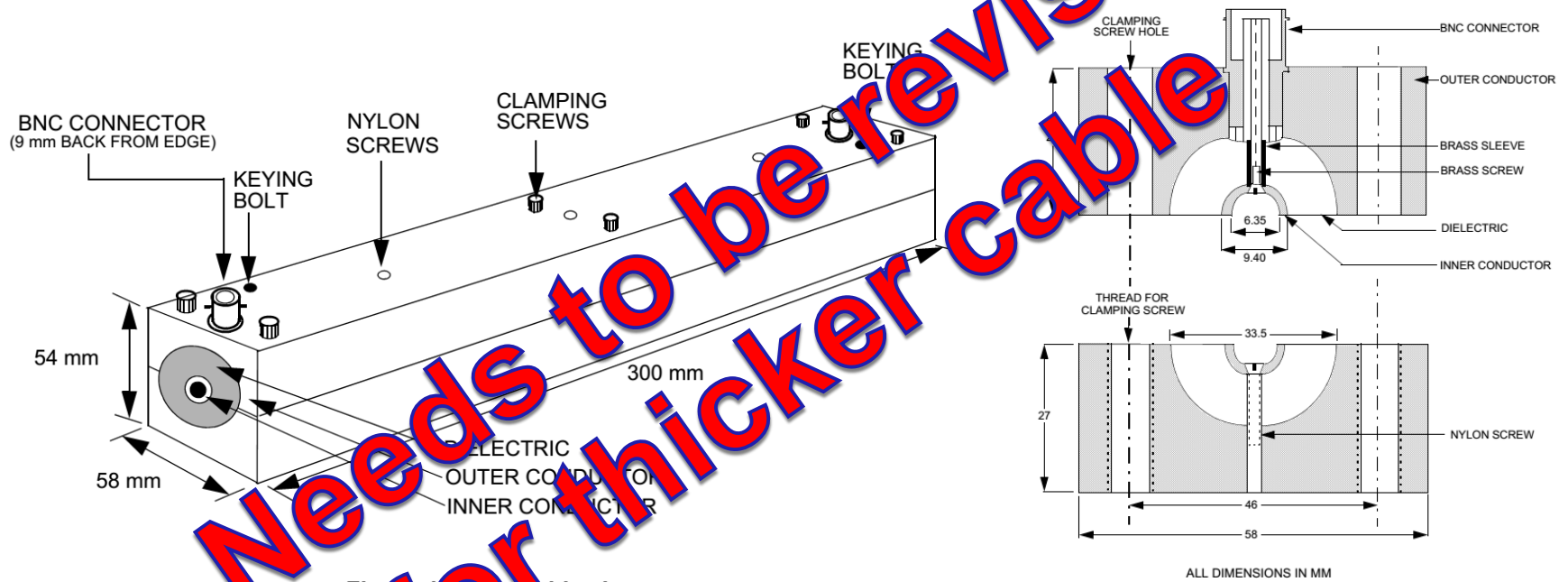

Figure 40B-1—Cable clamp

Figure 40B-2—Cross-section of cable clamp

Needs to be revised for thicker cable

Annex 105x.2 Cable clamp validation (1)

- In order to ensure the cable clamp described above is operating correctly, the following test procedure is provided. Prior to conducting the following test shown in Figure 105x-3, the clamp should be tested to ensure the insertion loss and return loss are as specified above. The cable clamp validation test procedure uses a well-balanced 4-pair Category 8 unshielded test cable or better that meets the specifications of 105x.1.
- The test hardware consists of the following:
 - a) Resistor network - Network consists of five $50 \pm 0.1\% \Omega$ resistors. Two resistors are connected in series as a differential termination for cable pairs and the other resistor is connected between the two and the ground plane as a common-mode termination.
 - b) Balun - 6 ports, laboratory quality with a 100Ω differential input, 50Ω differential output, and a 50Ω common-mode output:
 - Insertion Loss (100 Ω balanced <-> 50Ω unbalanced): < 1.2 dB (1-350MHz)
 - Return Loss: > 20 dB (1-350 MHz)
 - Longitudinal Balance: > 50 dB (1-350 MHz)
 - c) Test cable - 4-pair 100 QUTP Category 5 balanced cable at least 30 m long.
 - d) Chokes (2) - Wideband Ferrite Material:
 - Inter-diameter: 6.35 mm
 - Impedance: 250Ω @ 100 MHz
 - e) Ground plane - Copper sheet or equivalent.
 - f) Signal generator
 - g) Oscilloscope
 - h) Receiver

Needs to be revised for (TBD) GHz signal measurement?

Annex 105x.2 Cable clamp validation (2)

- With the test cable inserted in the cable clamp, a signal generator with 50 Ω output impedance is connected to one end of the cable clamp and an appropriate measurement instrument with a 50 Ω input impedance is connected to the other end. The signal generator shall be capable of providing a sine wave signal of 80 MHz to 2 GHz. The output of the signal generator is adjusted for a voltage of TBD Vrms (TBD Vpp) at TBD MHz on the oscilloscope. The remainder of the test is conducted without changing the signal generator voltage. The cable pairs not connected to the balun are terminated in a resistor network, although when possible it is recommended that each cable pair be terminated in a balun. It very important that the cable clamp, balun, receiver, and resistor networks have good contact with the ground plane. The TBD chokes, which are located next to each other, are located approximately TBD cm from the clamp. The cable between the clamp and the balun should be straight and not in contact with the ground plane.
- The differential-mode and common-mode voltage outputs of the balun should meet the limits shown in Table 105x.2 over the frequency range 80 MHz to 2 GHz for each cable pair. The differential mode voltage at the output of the balun must be increased by 3 dB to take into account the 100-to-50 impedance matching loss of the balun.
- NOTE - Prior to conducting the validation test the cable clamp should be tested without the cable inserted to determine the variation of the signal generator voltage with frequency at the output of the clamp. The signal generator voltage should be adjusted to TBD Vrms (TBD Vpp) at TBD MHz on the oscilloscope. When the frequency is varied from 20 MHz to 2 GHz, the voltage on the oscilloscope should not vary more than $\pm 7.5\%$. If the voltage varies more than $\pm 7.5\%$, then a correction factor must be applied at each measurement frequency

for (TBD) GHz and TBD dBm

Annex 105x.2 Cable clamp validation (3)

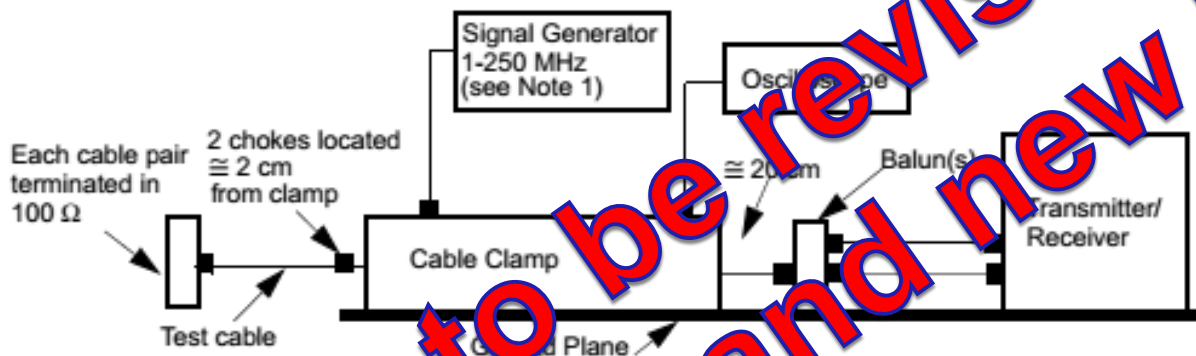

Figure 40B-1—Cable clamp validation test configuration

Table 40B-1—Common- and differential-mode output voltages

Frequency	Common-mode voltage	Differential-mode voltage
1-30 MHz	$<0.1 + 0.97(f/30)$ Vpp	$<2.4 + 19.68(f/30)$ mVpp
30-100 MHz	<1.07 Vpp	<22 mVpp
100-250 MHz	$<1.07 - 0.6(f-100)/170$ Vpp	<22 mVpp

Needs to be revised for (TBD) GHz and new limits