



Closing the Pmax to Vf ratio budget hole

Mike Dudek QLogic

Tao Hu QLogic

IEEE 802.3by Presented at ad hoc 2/17/16

- **This presentation is in support of comments #r01-16 and #r01-17**
- **It provides information on how the Pmax to Vf ratio budget hole described in dudek_3by_01-0116 can be closed and proposes one set of compromise parameter values to do that.**
- **Much of this material was discussed in the 2/10/16 and 2/17/16 and 2/24/16 ad-hocs and additional material from the presentations at those ad-hocs is included in the back-up.**
- **Those presentations showed that adding a Gaussian filter in the Tx in COM is the best way to make the Pmax to Vf ratio being used in COM match the Pmax to Vf ratio specified for the Tx. This is the method used in this presentation.**



Copper Cable results

Transmitter Characteristics at TP2

COM Pulse (by Gaussian source risetime)			
Package Length = 30mm Board Length = 151mm Default Package Gamma Default Board Gamma			
Rise Time [20% to 80%] (pS)	Pmax (V)	Vf (V)	Pmax /Vf
1	0.171	0.344	0.498
8	0.168	0.344	0.487
12	0.163	0.344	0.475
16	0.158	0.344	0.460
18	0.155	0.344	0.451

- COM Pulse (by Gaussian source risetime): COM simulated pulse at TP2 by varying Gaussian source risetime

Transmitter Characteristics @ TP2 w/o TX Equalization :



	COM Simulated PRBS9 @ TP2							
	Gaussian Filter Risetime 1ps	Gaussian Filter Risetime 8ps	Gaussian Filter Risetime 12ps	Gaussian Filter Risetime 16ps	Gaussian Filter Risetime 18ps	Units	SPEC (Table 92-6)	
Package Length	30					mm		
Host Board Length	151					mm		
Sigmae	5.918	5.904	5.889	5.873	5.865	mV		
Pmax (Linear fit pulse peak)	0.169	0.165	0.161	0.156	0.153	V		
SNDR (@ Sigman = 0)	29.113	28.944	28.74	28.474	28.322	dB	>=26dB	
Differential Peak to Peak Voltage	0.669	0.668	0.667	0.666	0.666	V	<=1.2V	
Vf (steady-state voltage)	0.341	0.342	0.342	0.342	0.342	V	0.34V=< Vf <=0.6V	
Pmax/Vf	0.495	0.484	0.472	0.456	0.448	N/A	>=0.45	
Sigman (for SNDR 26dB@TP2)	6.059	5.814	5.523	5.146	4.931	mV		
TXSNR (to achieve sigman above)	28.91	29.078	29.298	29.622	29.829	dB		

The allowed TXSNR does become somewhat greater when the risetime increases, but not by a lot. The existing value (28.4dB) still does leave a little unused margin.

COM Plots on TE 3m 25AWG 15.25dB Cable Channel (tracy_3by_01_0715.pdf)



TE 3m 25AWG 15.25dB attenuation

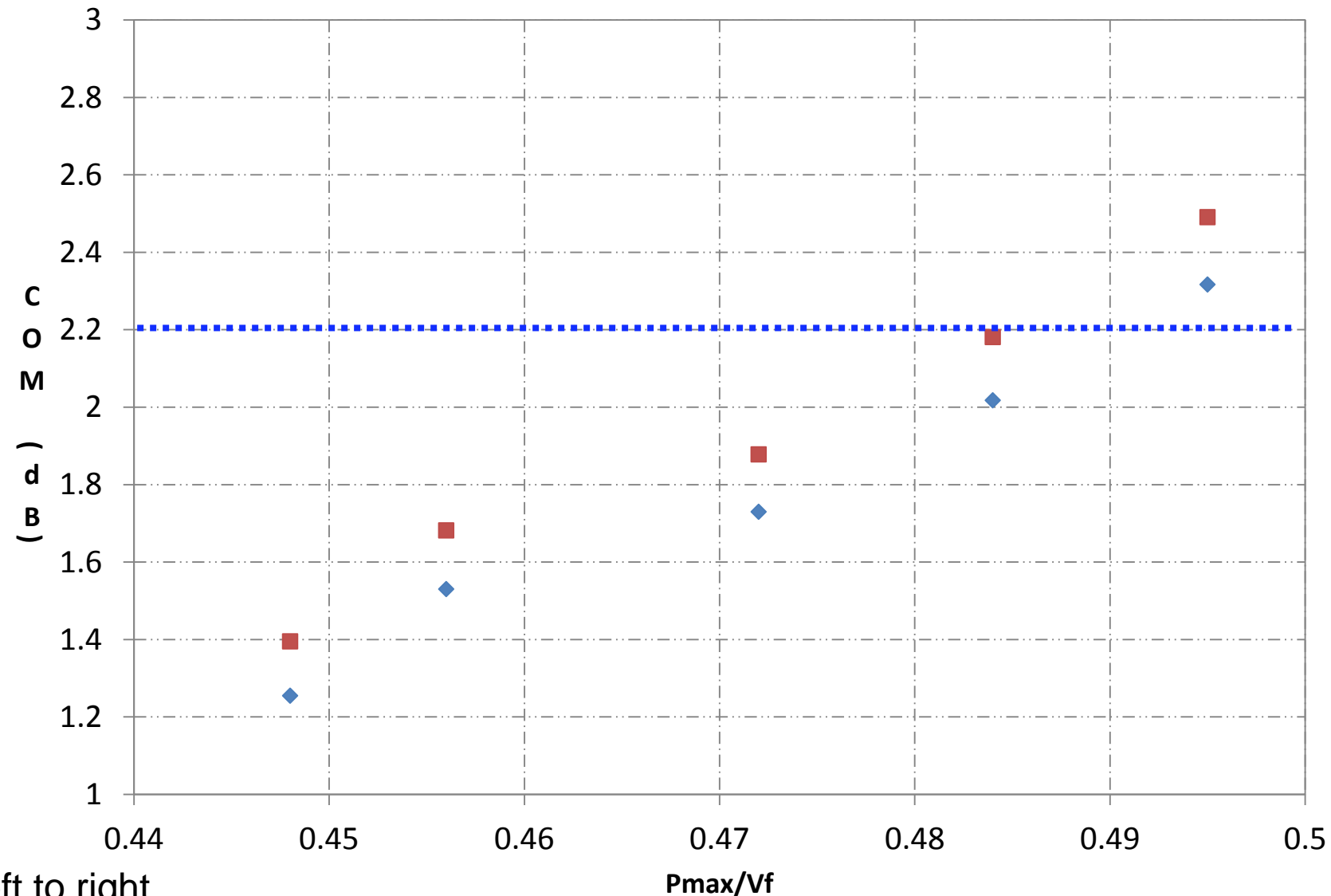

◆ SNR 28.4
■ SNR 29.83

z_p (TX)	[30]
z_p (NEXT)	[12]
z_p (FEXT)	[30]
z_p (RX)	[30]
C_p	[1.8e-4]
R_0	50
R_d	[55 55]
C_d	[2.5e-4]
z_p select	[1]
A_v	0.4
A_fe	0.6
A_ne	0.6
b_max(1)	0.35
b_max(2..N_b)	0.35
g_DC	[-16:1:0]
DER_0	1.00E-12

package_tl_tau	6.141E-03	ns
package_tl_gamma0_a1_a2	[0 1.734e-3 1.455e-4]	
package_Z_c	78.2	Ohm
board_tl_tau	6.191E-03	ns
board_tl_gamma0_a1_a2	[0 4.114e-4 2.547e-4]	
board_Z_c	109.8	Ohm
z_bp (TX)	151	mm
z_bp (NEXT)	72	mm
z_bp (FEXT)	72	mm
z_bp (RX)	151	mm

From left to right
Risetime(Gaussian filter): 18ps, 16ps, 12ps, 8ps, 1ps

COM Plots on TE 3m 25AWG 15.35dB Cable Channel (tracy_3by_01_0715.pdf)



TE 3m 25AWG 15.35dB

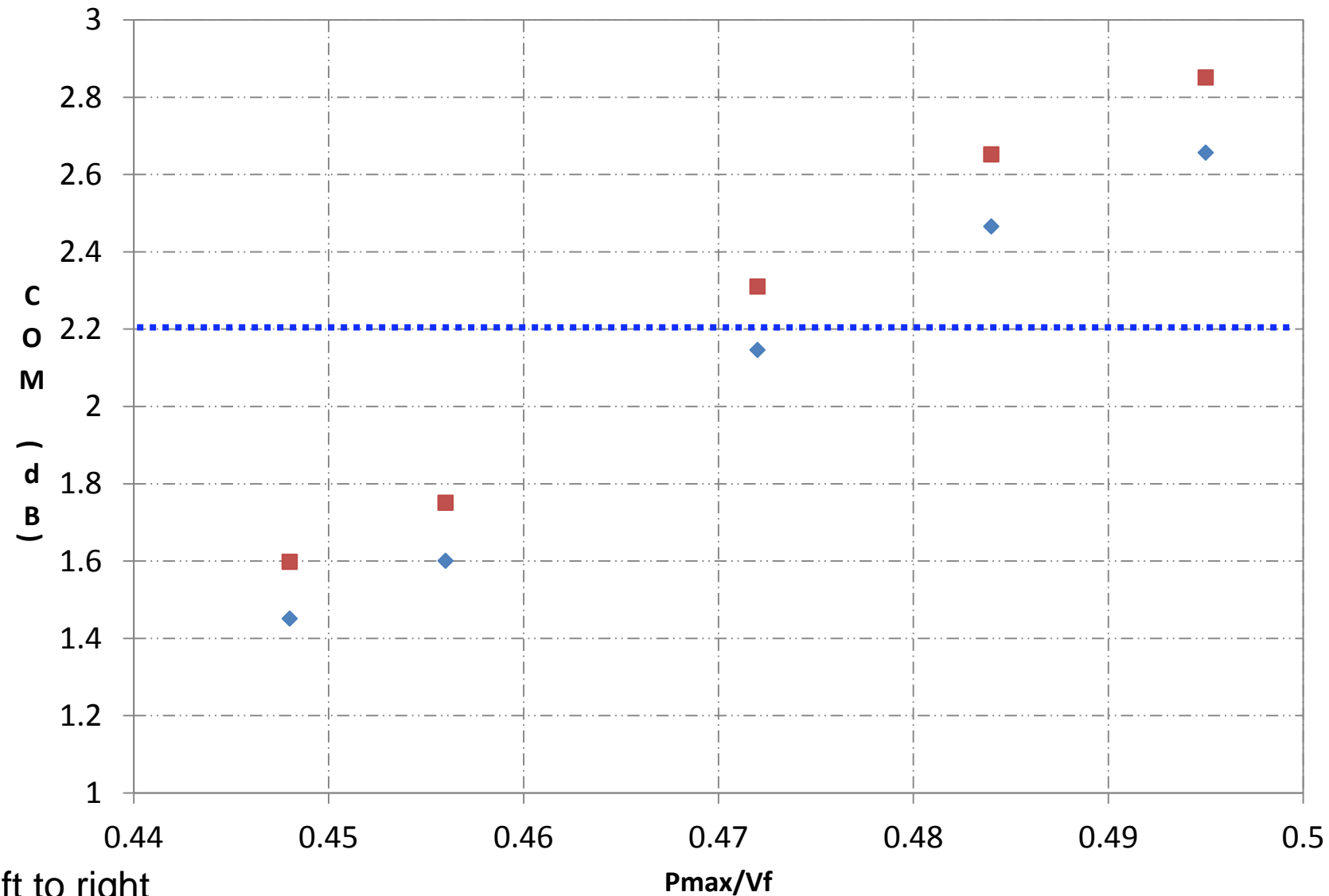

z_p (TX)	[30]
z_p (NEXT)	[12]
z_p (FEXT)	[30]
z_p (RX)	[30]
C_p	[1.8e-4]
R_0	50
R_d	[55 55]
C_d	[2.5e-4]
z_p select	[1]
A_v	0.4
A_fe	0.6
A_ne	0.6
b_max(1)	0.35
b_max(2..N_b)	0.35
g_DC	[-16:1:0]
DER_0	1.00E-12

◆ SNR 28.4
■ SNR 29.83

package_tl_tau	6.141E-03	ns
package_tl_gamma0_a1_a2	[0 1.734e-3 1.455e-4]	
package_Z_c	78.2	Ohm
board_tl_tau	6.191E-03	ns
board_tl_gamma0_a1_a2	[0 4.114e-4 2.547e-4]	
board_Z_c	109.8	Ohm
z_bp (TX)	151	mm
z_bp (NEXT)	72	mm
z_bp (FEXT)	72	mm
z_bp (RX)	151	mm

From left to right
Risetime(Gaussian filter): 18ps, 16ps, 12ps, 8ps, 1ps

COM Plots on TE 3m 26AWG 15.96dB Cable Channel (tracy_3by_01_0715.pdf)



TE 3m 26AWG 15.96dB

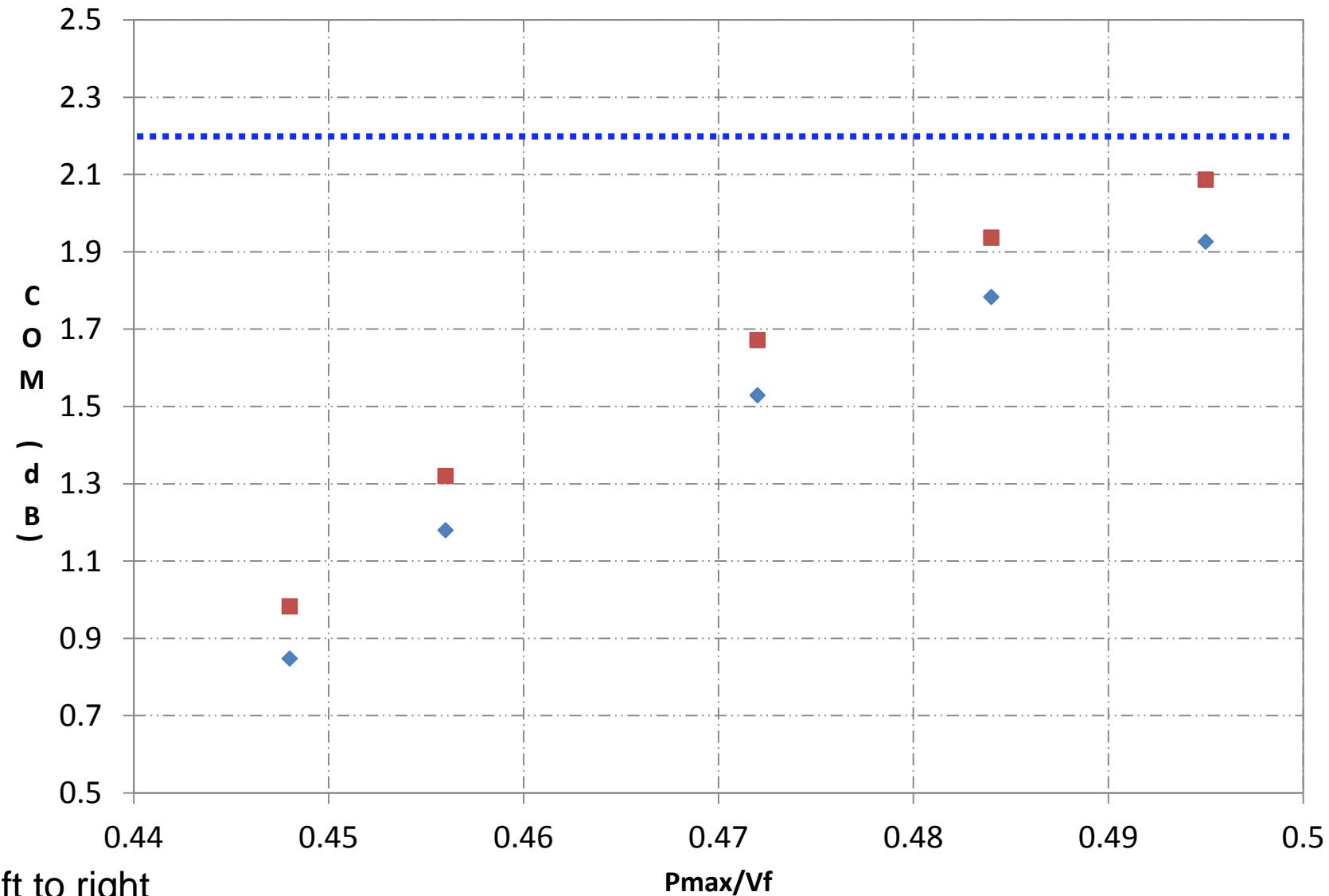

◆ SNR 28.4
■ SNR 29.83

z_p (TX)	[30]
z_p (NEXT)	[12]
z_p (FEXT)	[30]
z_p (RX)	[30]
C_p	[1.8e-4]
R_0	50
R_d	[55 55]
C_d	[2.5e-4]
z_p select	[1]
A_v	0.4
A_fe	0.6
A_ne	0.6
b_max(1)	0.35
b_max(2..N_b)	0.35
g_DC	[-16:1:0]
DER_0	1.00E-12

package_tl_tau	6.141E-03	ns
package_tl_gamma0_a1_a2	[0 1.734e-3 1.455e-4]	
package_Z_c	78.2	Ohm
board_tl_tau	6.191E-03	ns
board_tl_gamma0_a1_a2	[0 4.114e-4 2.547e-4]	
board_Z_c	109.8	Ohm
z_bp (TX)	151	mm
z_bp (NEXT)	72	mm
z_bp (FEXT)	72	mm
z_bp (RX)	151	mm

From left to right
Risetime(Gaussian filter): 18ps, 16ps, 12ps, 8ps, 1ps

COM Plots on TE 3m 26AWG 15.99dB Cable Channel (tracy_3by_01_0715.pdf)



TE 3m 26AWG 15.99dB

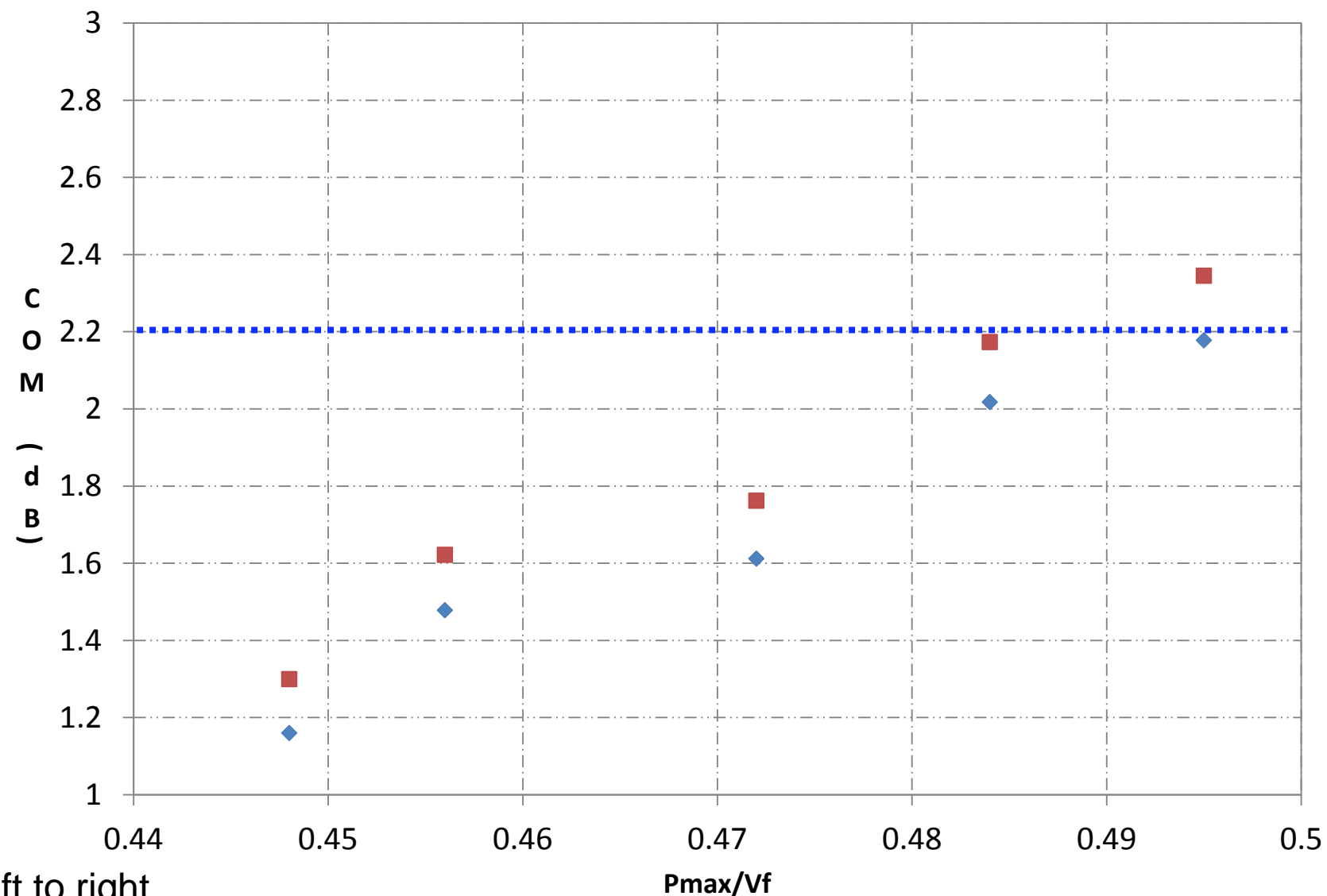

From left to right
Risetime(Gaussian filter): 18ps, 16ps, 12ps, 8ps, 1ps

z_p (TX)	[30]
z_p (NEXT)	[12]
z_p (FEXT)	[30]
z_p (RX)	[30]
C_p	[1.8e-4]
R_0	50
R_d	[55 55]
C_d	[2.5e-4]
z_p select	[1]
A_v	0.4
A_fe	0.6
A_ne	0.6
b_max(1)	0.35
b_max(2..N_b)	0.35
g_DC	[-16:1:0]
DER_0	1.00E-12

package_tl_tau	6.141E-03	ns
package_tl_gamma0_a1_a2	[0 1.734e-3 1.455e-4]	
package_Z_c	78.2	Ohm
board_tl_tau	6.191E-03	ns
board_tl_gamma0_a1_a2	[0 4.114e-4 2.547e-4]	
board_Z_c	109.8	Ohm
z_bp (TX)	151	mm
z_bp (NEXT)	72	mm
z_bp (FEXT)	72	mm
z_bp (RX)	151	mm

COM Plots on FCI 3m 26AWG 17.59dB Cable Channel (zambell_090215_25GE_adhoc-v2.pdf)



FCI 3m 26AWG 17.99dB

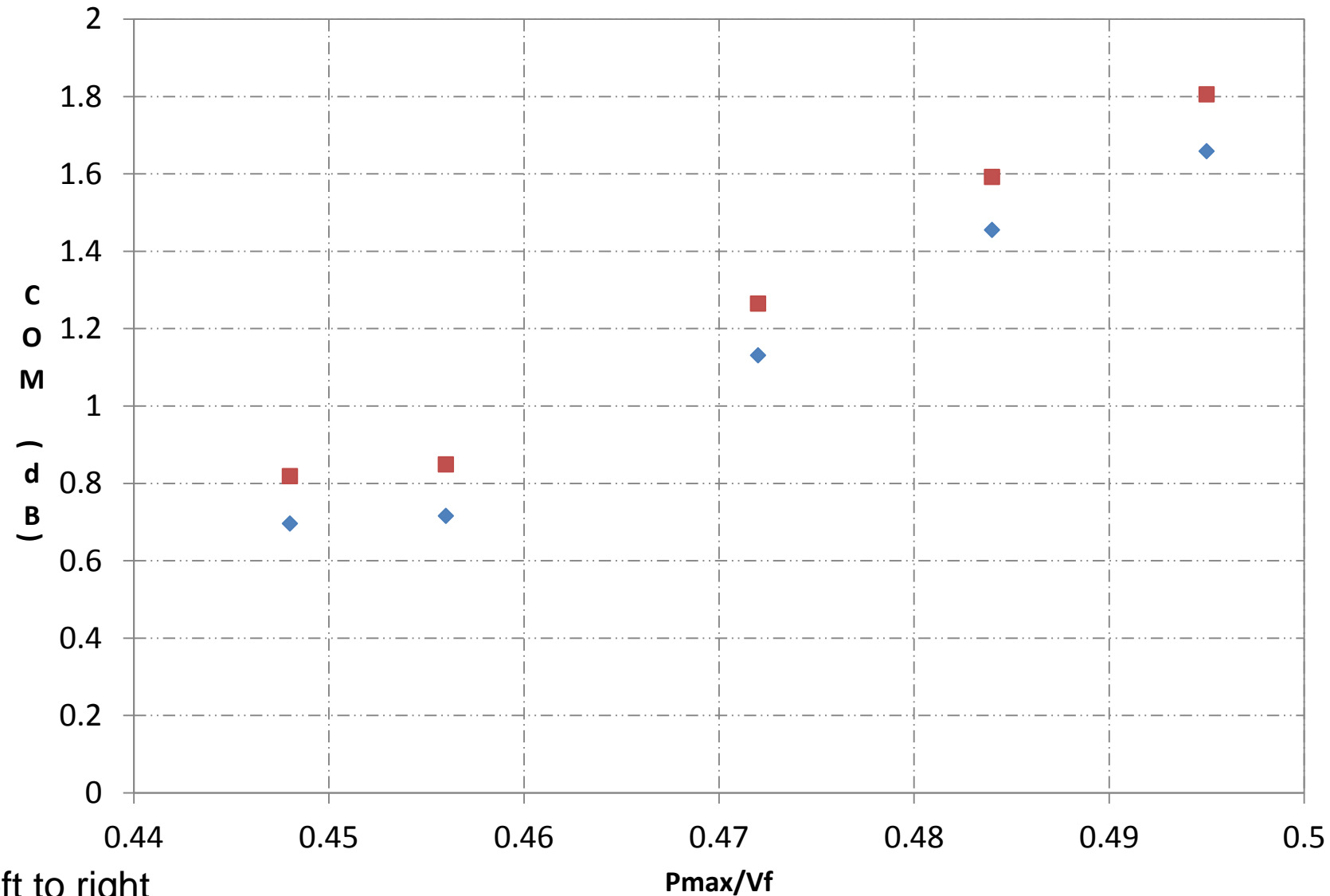

From left to right
Risetime(Gaussian filter): 18ps, 16ps, 12ps, 8ps, 1ps

z_p (TX)	[30]
z_p (NEXT)	[12]
z_p (FEXT)	[30]
z_p (RX)	[30]
C_p	[1.8e-4]
R_0	50
R_d	[55 55]
C_d	[2.5e-4]
z_p select	[1]
A_v	0.4
A_fe	0.6
A_ne	0.6
b_max(1)	0.35
b_max(2..N_b)	0.35
g_DC	[-16:1:0]
DER_0	1.00E-12

package_tl_tau	6.141E-03	ns
package_tl_gamma0_a1_a2	[0 1.734e-3 1.455e-4]	
package_Z_c	78.2	Ohm
board_tl_tau	6.191E-03	ns
board_tl_gamma0_a1_a2	[0 4.114e-4 2.547e-4]	
board_Z_c	109.8	Ohm
z_bp (TX)	151	mm
z_bp (NEXT)	72	mm
z_bp (FEXT)	72	mm
z_bp (RX)	151	mm

Investigation of COM Parameters on TE 3m 26AWG Cable Channel (shanbhag_020415_25GE_adhoc_v2.pdf) (13.82dB)

TE 3m 26AWG Cable: DER 1E-5 bmax 1

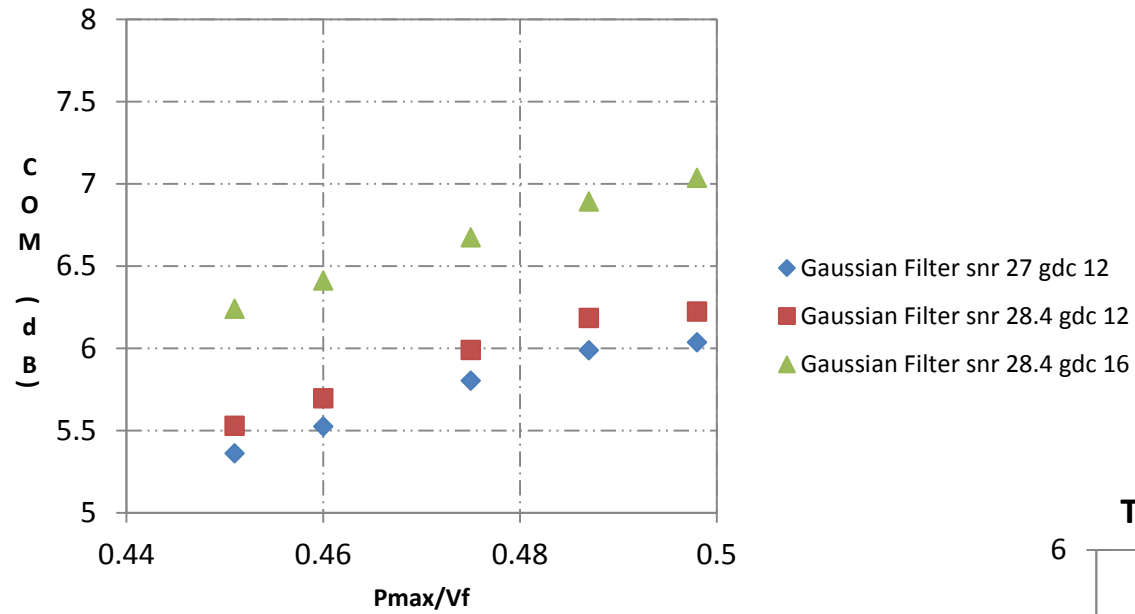

TE 3m 26AWG Cable: DER 1E-12 bmax 0.35

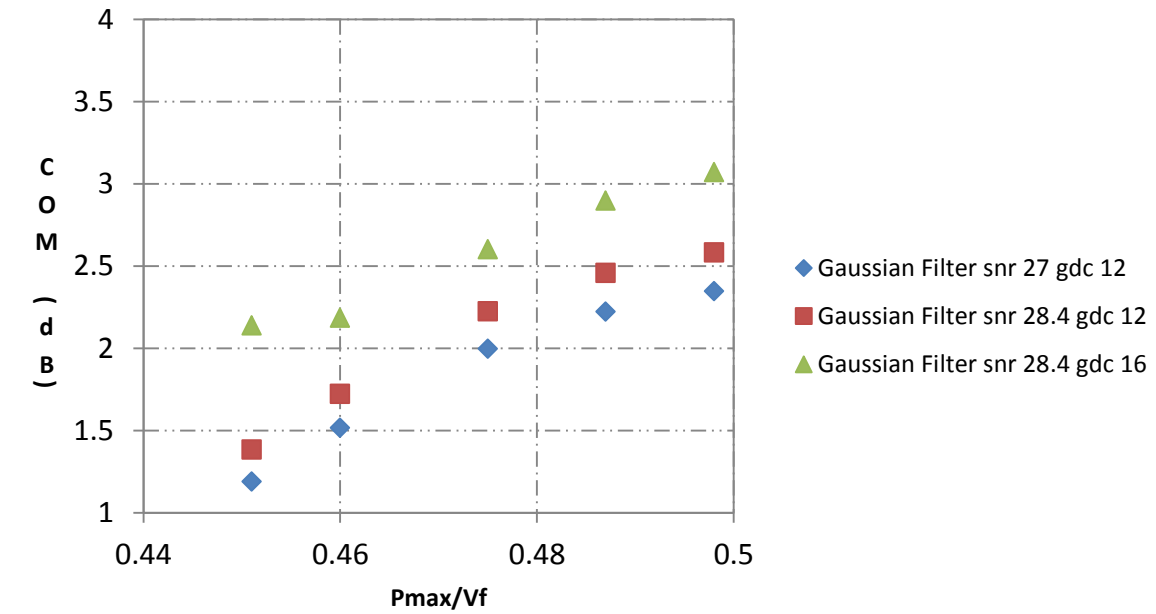

TE 3m 26AWG Cable: : DER 1E-8 bmax 0.5

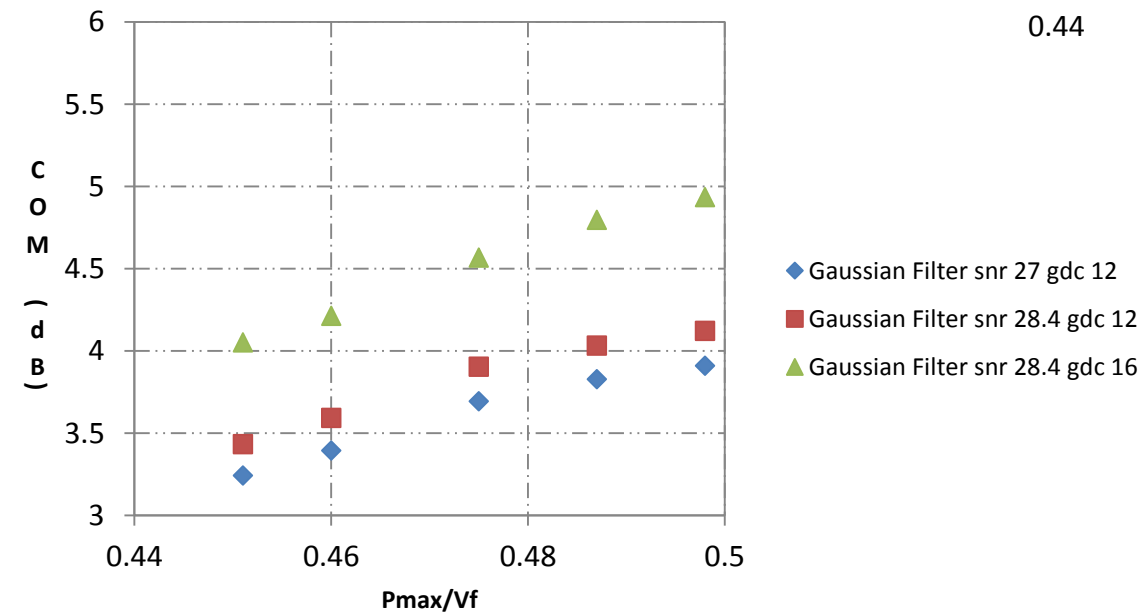

From left to right
Gaussian filter risetime: 18ps, 16ps, 12ps, 8ps, 1ps

Investigation of COM Parameters on TE 3m 28AWG Cable Channel (shanbhag_020415_25GE_adhoc_v2.pdf) (17.82dB)

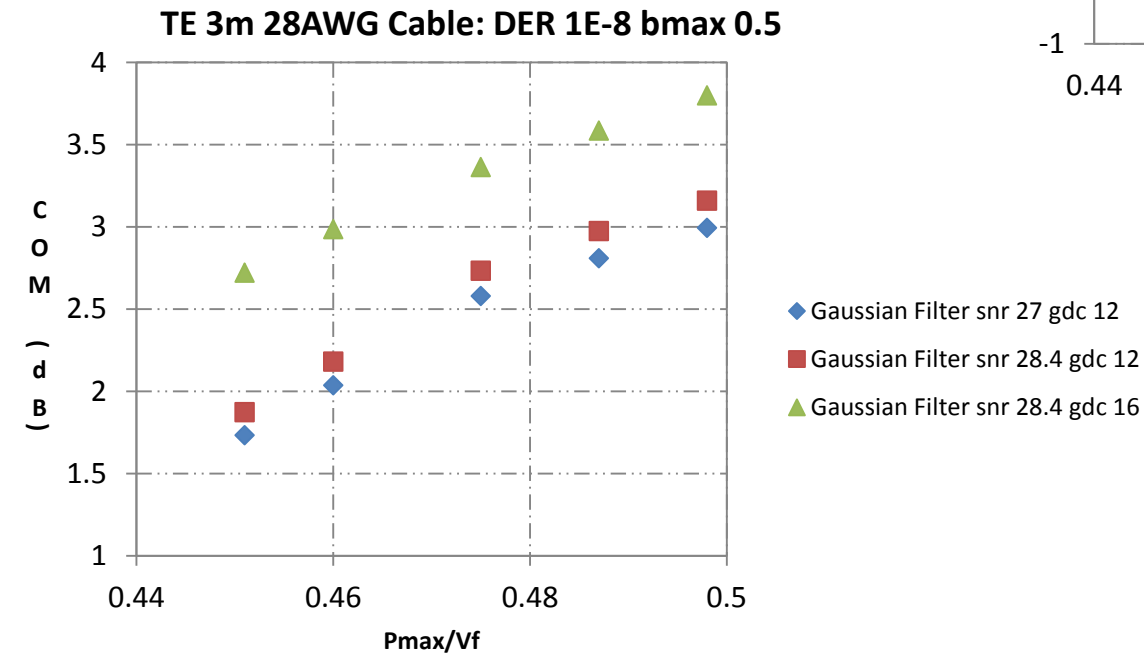
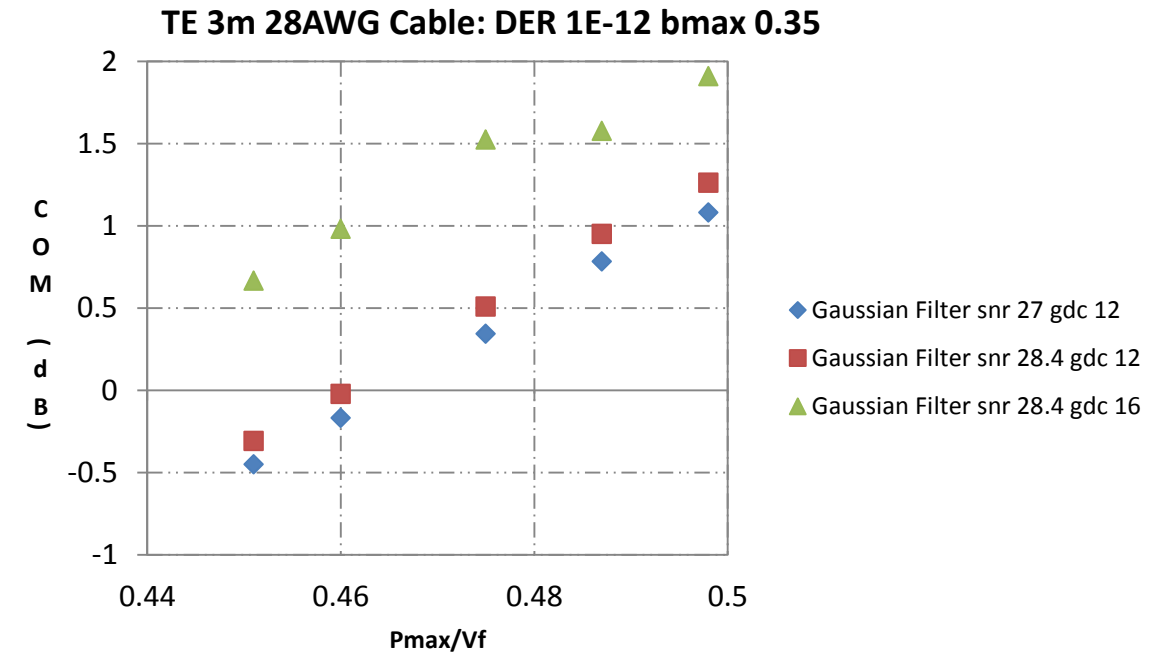
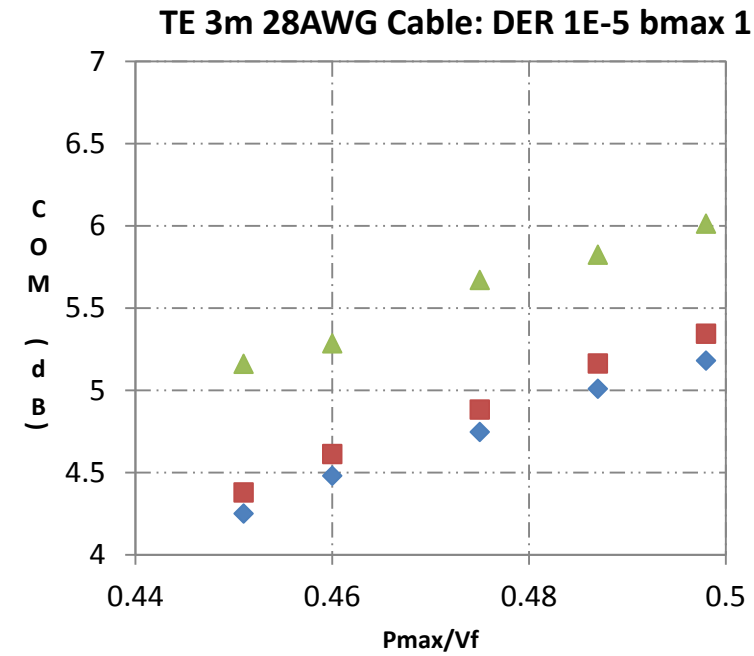

From left to right
Gaussian filter risetime: 18ps, 16ps, 12ps, 8ps, 1ps

Investigation of COM Parameters on TE 3m 30AWG Cable Channel (shanbhag_020415_25GE_adhoc_v2.pdf)

TE 3m 30AWG Cable: DER 1E-5 bmax 1

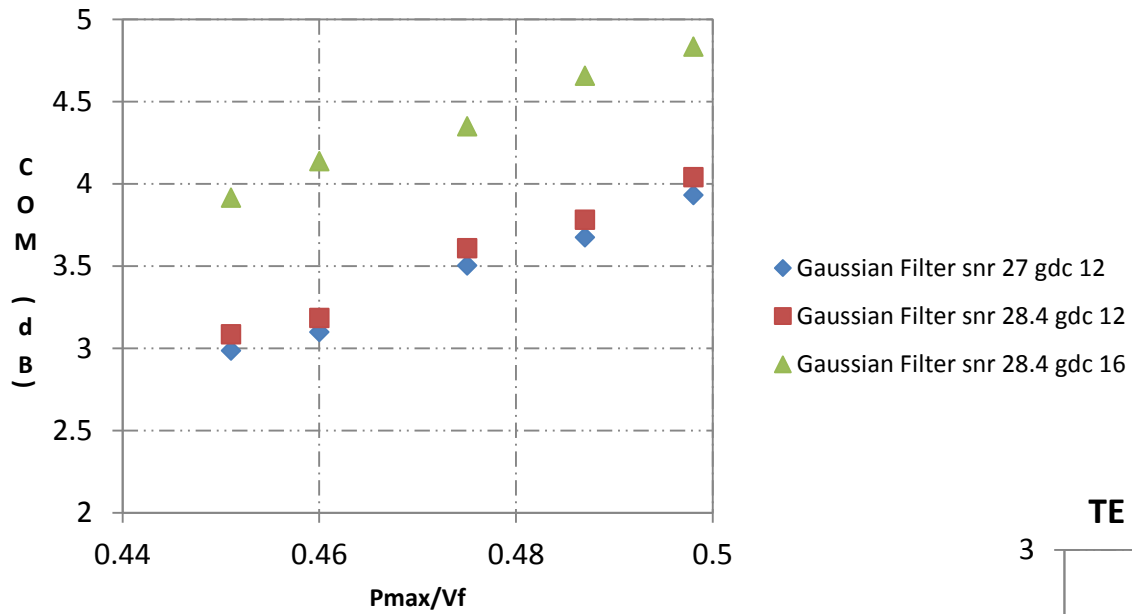

TE 3m 30AWG Cable: DER 1E-12 bmax 0.35

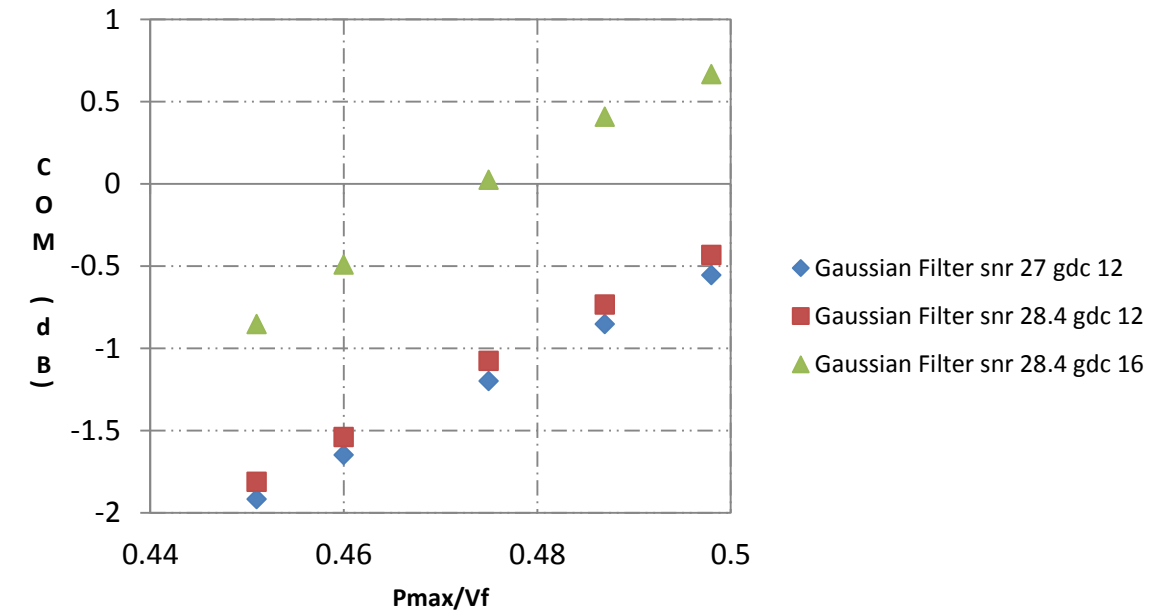

TE 3m 30AWG Cable: DER 1E-8 bmax 0.5

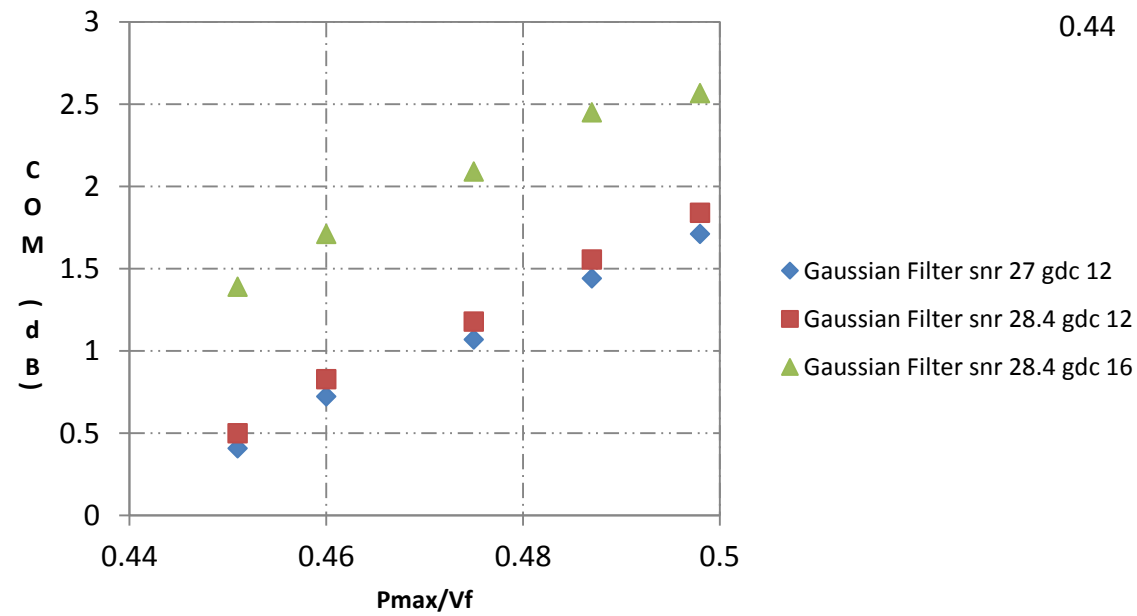

From left to right
Gaussian filter risetime: 18ps, 16ps, 12ps, 8ps, 1ps

Investigation of COM Parameters on Amphenol 5m 26AWG Cable Channel

Amphenol 5m 26AWG Cable : DER 1E-5 bmax 1

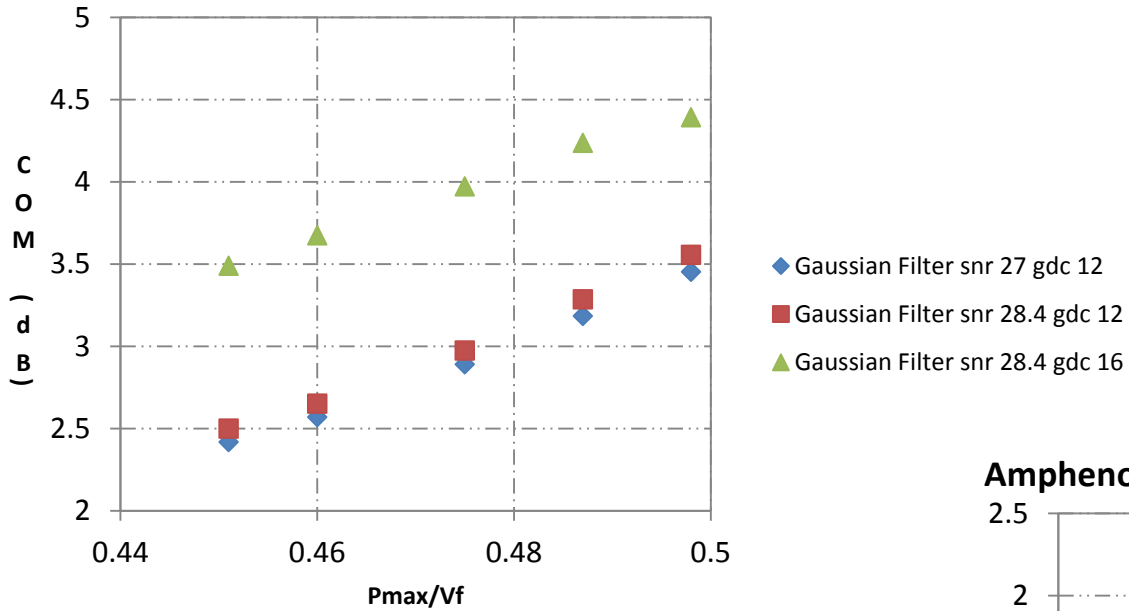

Amphenol 5m 26AWG Cable: DER 1E-12 bmax 0.35

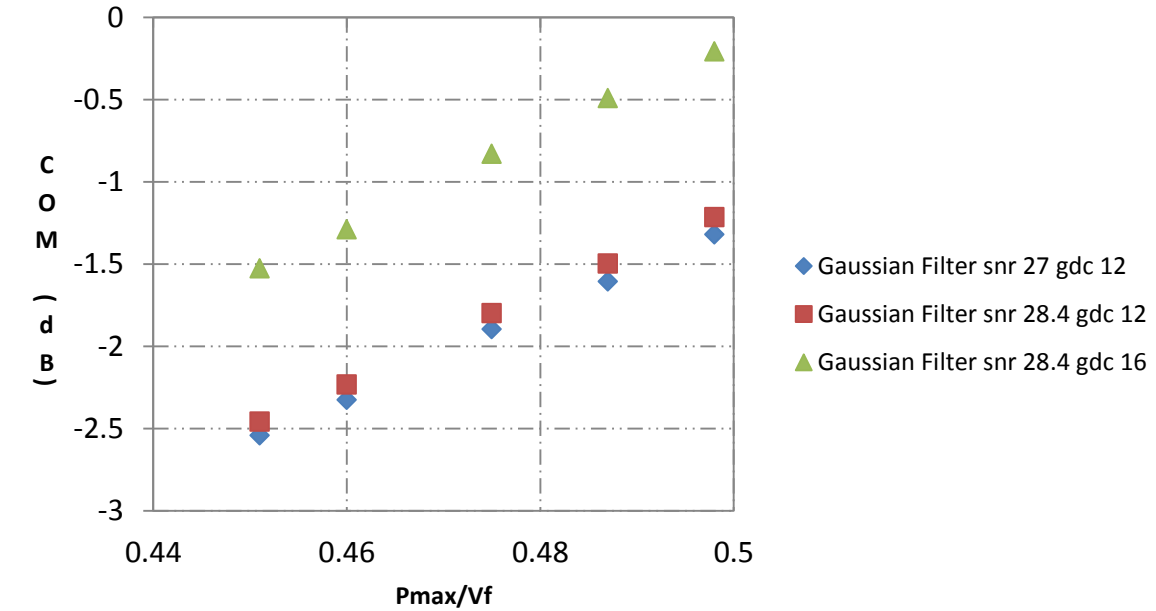

Amphenol 5m 26AWG Cable: DER 1E-8 bmax 0.5

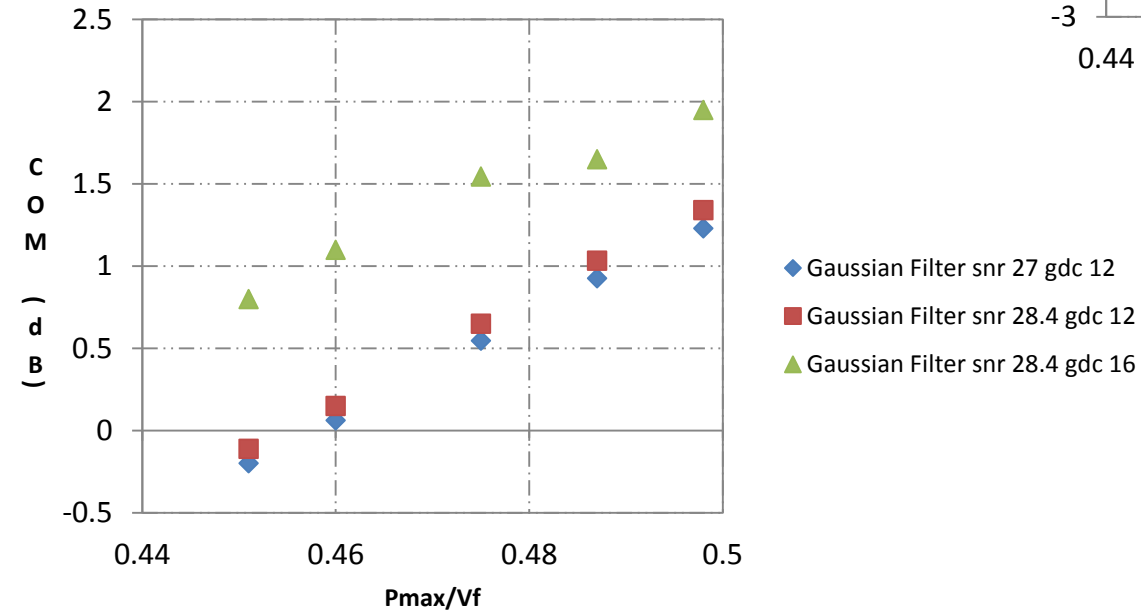

From left to right
Gaussian filter risetime: 18ps, 16ps, 12ps, 8ps, 1ps

Conclusions and Comments.

- The hole in the spec is not small being between 0.7 dB and 1.5dB in COM
- For CA-N we are already using TxSNR of 28.4dB and Gdc of 16dB. I recommend we change TxSNR to **29dB** as this is spare margin. However we've already tightened the Rx spec significantly by using Gdc of 16dB and allowing COM of 2.2dB. The table below gives the possible trade-offs between cable performance and Tx performance.
- Using 27dB for TxSNR for CA-L and CA-S leaves margin on the table. We should definitely change TxSNR for these cases to match the CA-N value as this relaxes the cable spec with no other impact. I recommend we also consider increase Gdc for CA-L and CA-S to cancel the effect of the Gaussian filter addition so that there is no change to the effective cable specification.

Option	Pmax/Vf ratio Tx spec	Gaussian filter in Tx (ps) in COM	Equivalent increase in required COM for CA-N (dB) spec	Proposed Gdc in COM for CA-S and CA-L (dB) (Cable spec effectively the same)	Comments.
A	0.46	16	0.7	16	Still slightly tighter Tx spec, but probably makes 3m no FEC not possible.
B	0.47	12	0.25	15	3m no FEC very marginal
C	0.49	8	0.05	13	My recommendation
D	0.5	1	0	12	
E	0.45	18	1.0	>16 not recommended	3m no FEC out of question

With Tx_SNR of 29dB. If Tx_SNR is at 28.4dB the cable specs will be approx. 0.1dB COM more stringent.



Backplane results

- **The effect of using $A_v=0.43$ (With A_{fe} and $A_{ne} = 0.63$) is shown. This is justified because previous work has shown that these are better values for the Min value of V_f at TP0a. (see Mellitz_040815_25GE_adhoc)**
- **The effect of increasing the max CTLE gain to 16dB (same as for no-fec cable) is shown. (This could be used to tighten the specification on the Rx somewhat rather than tightening the specification on the Tx and/or channel.) Note that as was discussed when this was adopted for the no-fec cable case this doesn't mean that an Rx has to have a 16dB gain CTLE, just that it provides equivalent performance to one that does.**

Transmitter Characteristics @ TP0a



	COM Simulated PRBS9 @ TP0a							Units	SPEC (Table 92-6)
	Gaussian Filter Risetime 1ps	Gaussian Filter Risetime 8ps	Gaussian Filter Risetime 12ps	Gaussian Filter Risetime 16ps	Gaussian Filter Risetime 20ps	Gaussian Filter Risetime 16ps			
Package Length	30					30	mm		
Av	0.4					0.43	V		
Sigmae	2.456	2.393	2.354	2.33	2.279	2.504	mV		
Pmax (Linear fit pulse peak)	0.293	0.284	0.273	0.26	0.244	0.279	V		
SNDR (@ Sigman = 0)	41.543	41.473	41.285	40.94	40.602	40.94	dB	>=27dB	
Differential Peak to Peak Voltage	0.755	0.751	0.748	0.745	0.741	0.801	V	<=1.2V	
Vf (steady-state voltage)	0.364	0.364	0.364	0.364	0.364	0.391	V	0.4V=< Vf <=0.6V	
Pmax/Vf	0.805	0.779	0.749	0.713	0.671	0.713	N/A	>=0.71	
Sigman (for SNDR 27dB@TP0a)	12.871	12.437	11.962	11.360	10.672	12.212	mV		
TXSNR (to achieve sigman above)	27.155	27.158	27.165	27.179	27.194	27.179	dB		

COM Plots on Mellitz 35dB Channel (mellitz_3bj_01_0713.pdf)

Mellitz 35dB Channel : DER 1E-5 bmax 1

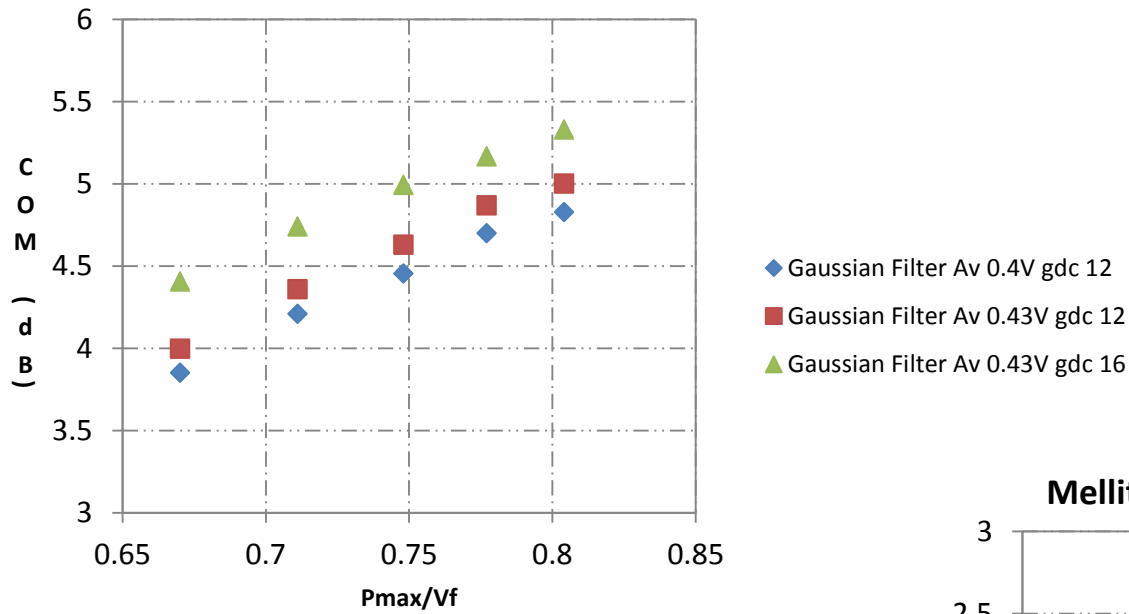

Mellitz 35dB Channel : DER 1E-12 bmax 0.35

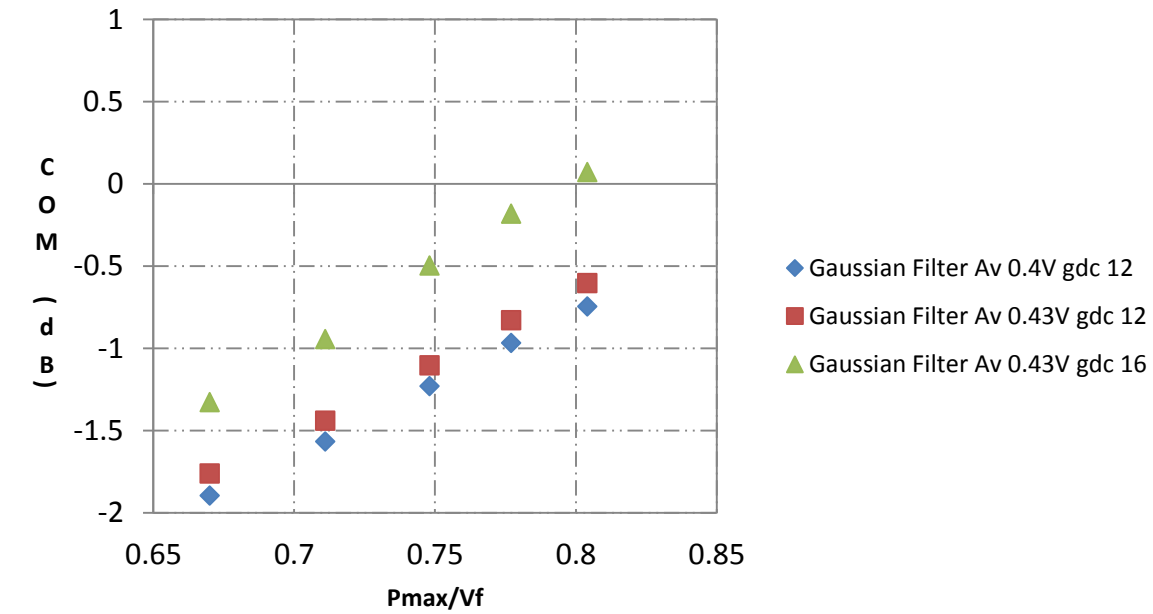

Mellitz 35dB Channel : DER 1E-8 bmax 0.5

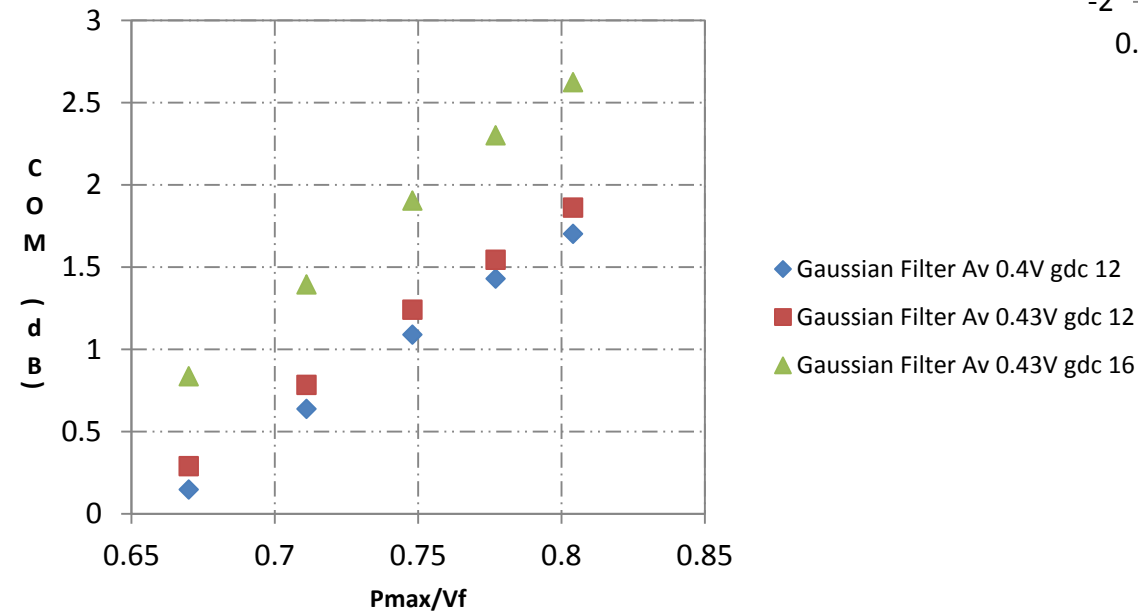

From left to right
Gaussian filter risetime: 20ps, 16ps, 12ps, 8ps, 1ps

COM Plots on Beth 32dB Channel (kochuparambil_3bj_01_0913.pdf)

Beth 32dB Channel : DER 1E-5 bmax 1

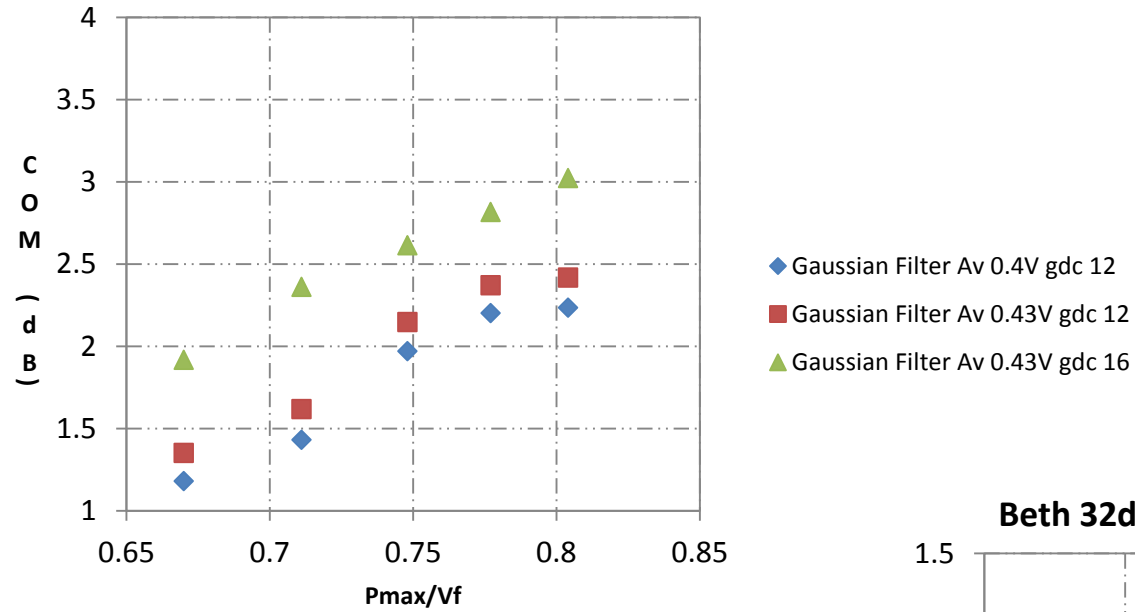

Beth 32dB Channel : DER 1E-12 bmax 0.35

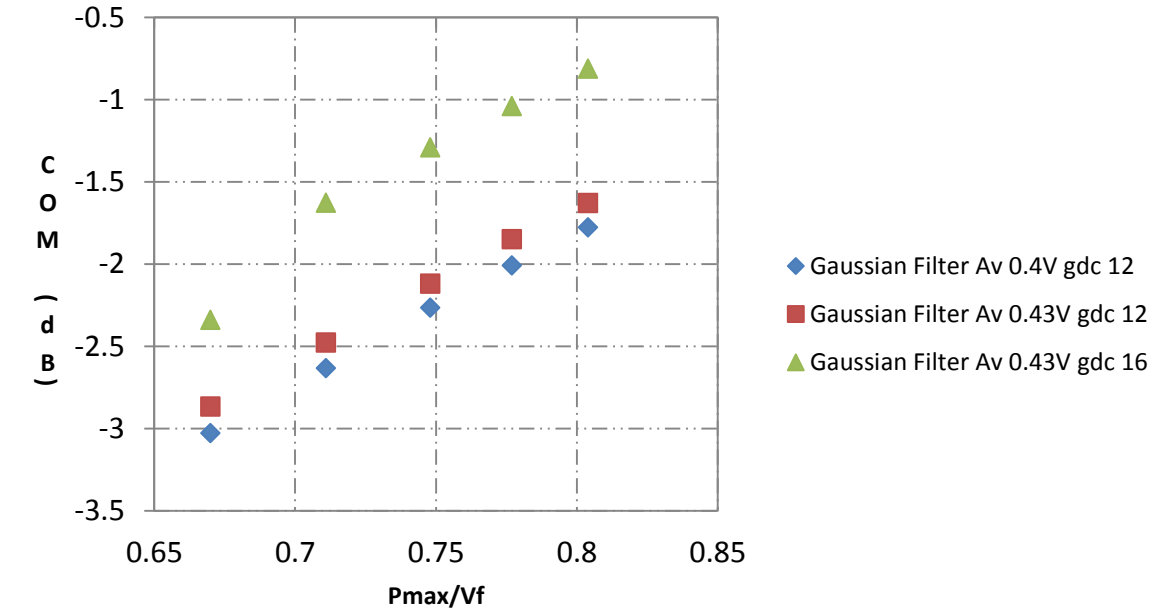

Beth 32dB Channel : DER 1E-8 bmax 0.5

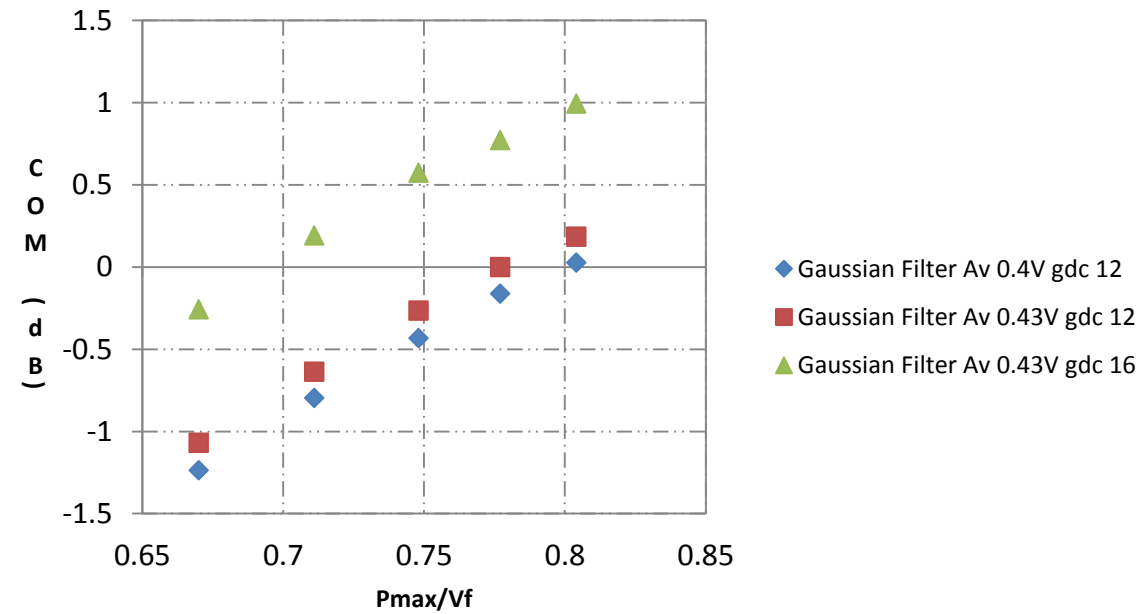

From left to right
Gaussian filter risetime: 20ps, 16ps, 12ps, 8ps, 1ps

COM Plots on Tracy 30dB Channel (tracy_3bj_01_0713.pdf)

Tracy 30dB Channel : DER 1E-5 bmax 1

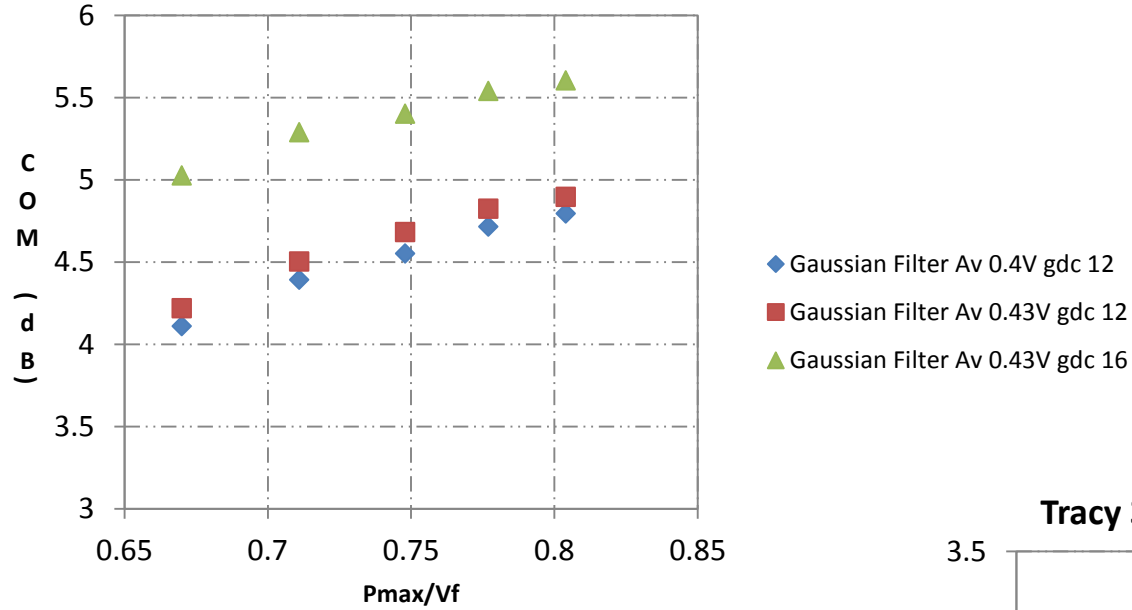

Tracy 30dB Channel : DER 1E-12 bmax 0.35

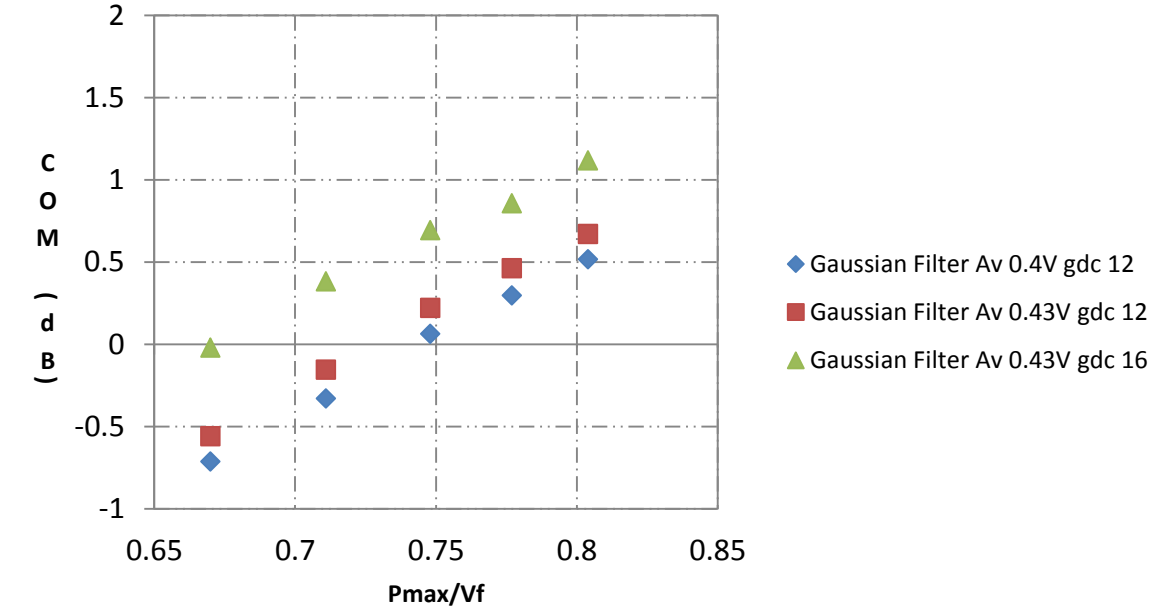

Tracy 30dB Channel : DER 1E-8 bmax 0.5

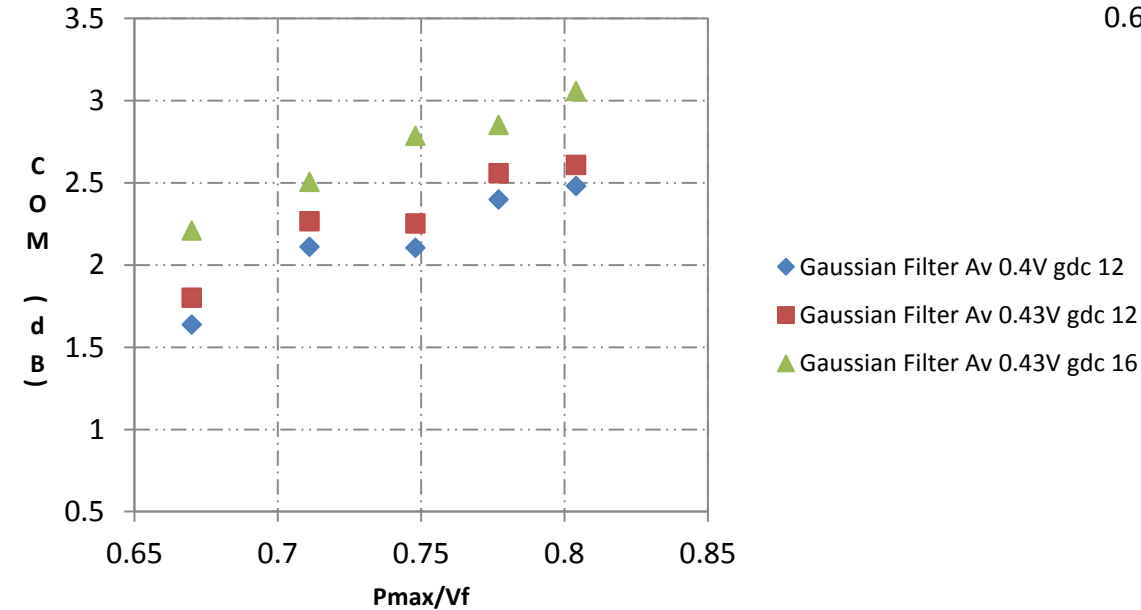

From left to right
Gaussian filter risetime: 20ps, 16ps, 12ps, 8ps, 1ps

COM Plots on Shanbhag 18.7dB Channel (shanbhag_03_0411.pdf)

Shanbhag 18.7dB Channel : DER 1E-5 bmax 1

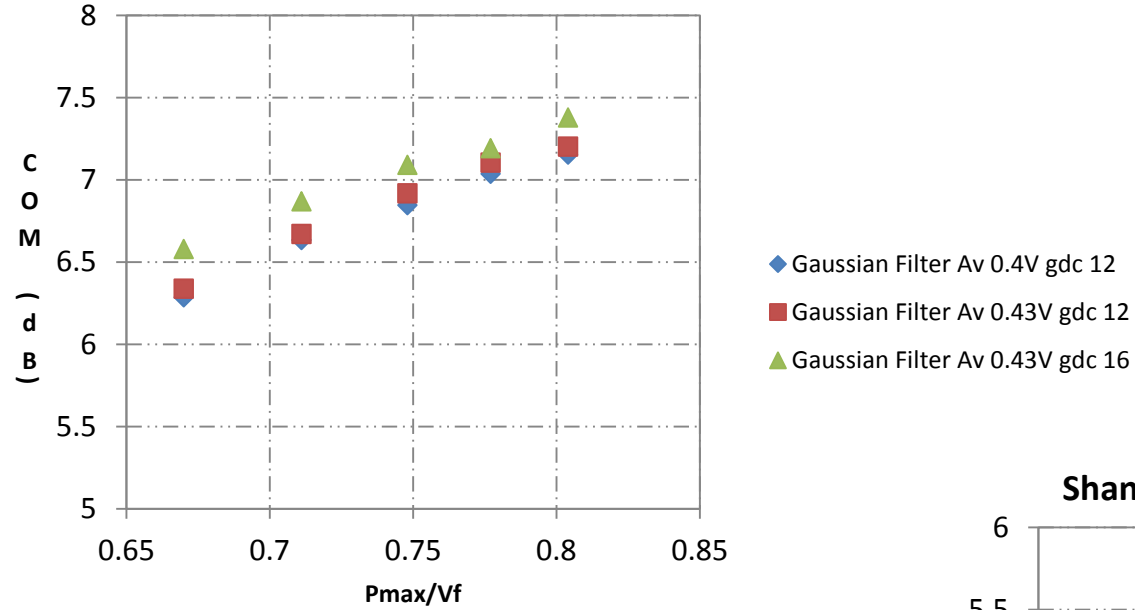

Shanbhag 18.7dB Channel : DER 1E-12 bmax 0.35

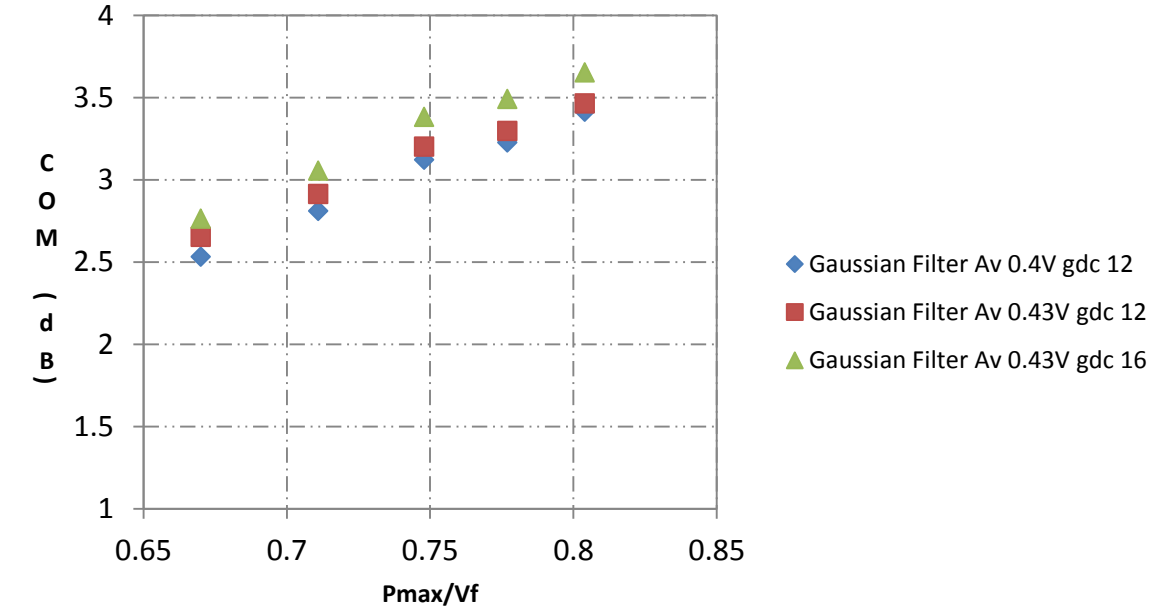

Shanbhag 18.7dB Channel : DER 1E-8 bmax 0.5

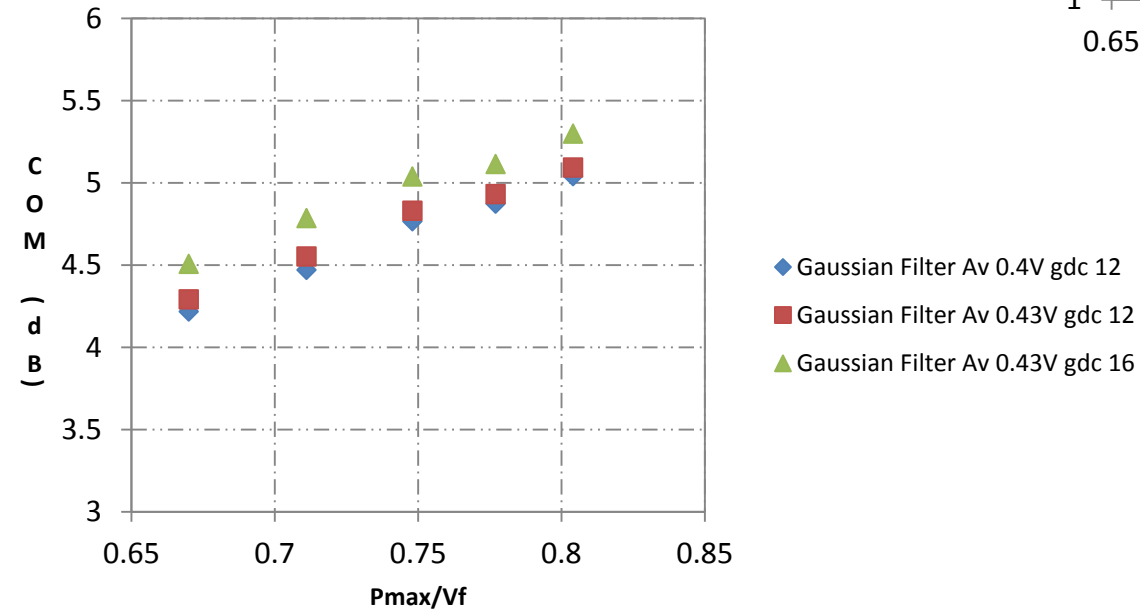

From left to right
Gaussian filter risetime: 20ps, 16ps, 12ps, 8ps, 1ps

- The hole in the spec is not small being between 0.5 dB and 1.1dB in COM
- Propose that A_v is increased from 0.4 to 0.43 and A_{fe} and A_{ne} should be changed from 0.6 to 0.63. This better matches the V_f specification of the Tx at TP0a.
- The following are different ways to close the budget.

Option	Pmax/ V_f ratio Tx spec	Gaussian filter in Tx (ps) in COM	Change AV ($A_v=0.43$, A_{fe} , $A_{ne}=0.63$) in COM	Change gdc in COM to 16dB	Comments.
A	0.81	No	No	No	Least changes. Most difficult for Tx.
B	0.78	8	Yes	No	Little change in channel spec.
C	0.75	12	Yes	No	Approx 0.3dB COM tighter channel spec
D	0.75	12	Yes	Yes	Little change in channel spec. Somewhat better Rx needed, but no better than no-fec Cable.
E	0.71	16	Yes	No	Equivalent to approx 0.4 to 1.0dB more stringent COM spec for the channel.

- **Propose Option D**



Backup – Introduction and methodology

Introduction (No change)

- **Dudek_3by_01_0116 showed that there is a hole in the backplane and copper cable budgets due to the Tx specifications for Pmax to Vf ratio being more relaxed than the effective value for this ratio used in the COM transmitter for the cable/backplane channel test.**
- **The presentation was in support of comments # i-55 and i-60 against draft 3.0 which suggested that the Tx specifications should be tightened to match the value used for testing the channel. These comments were rejected with the response.**

REJECT.

There is not sufficient consensus to resolve at this meeting.

- **There was a feeling that the proposed solution was too stringent on the Tx and that a compromise should be made that “shared the pain” between the Tx and the channel.**
- **This presentation investigates the Trade off between this parameter and Channel COM**

Methodology (added Gaussian filter degradation option)

- The COM channel up to the Tx test points was duplicated as close as possible in ADS
- The output waveform at the test point was generated using an ADS Tx with the amplitude matching the amplitude used in COM and using a very fast risetime as is used in COM.
- The resulting waveform was then analyzed using the Tx test methodology to determine the Pmax to Vf ratio
- Four different methods were then used to degrade the Tx to reduce this ratio.
 - Risetime – A trapezoidal risetime is used. Advantage – easiest to understand. Disadvantage requires COM code modification to change the risetime.
 - Package Length (pkglen). The Tx package length is increased. (Advantage – no Change to COM code. Disadvantage – increases the reflection time within the package).
 - Gamma - The loss of the package is increased for just the Tx. (Advantage- no increase in reflection time. Disadvantage - COM code needs modification to have different Gamma factors for the Tx and Rx.
 - Add a Gaussian filter in the Tx. Advantages – latest COM code incorporates this. Has the least effect on sigma e and Vf (see later)

- **COM is calculated for a number of different channels as a function of the Pmax to Vf ratio for the different degradation methods.**
- **Some alternative methods of closing the budget were investigated.**

Transmitter Characteristics at TP2



ADS PRBS9 (by die rise time)				COM Pulse (by package length)				COM Pulse (by Gamma)			
Package Length = 30mm Board Length = 151mm Default Package Gamma Default Board Gamma				Board Length = 151mm Default COM Source Default Package Gamma Default Board Gamma				Default COM Source Package Length = 30mm Board Length = 151mm Default Board Gamma			
Rise Time [20% to 80%] (pS)	Pmax (V)	Vf (V)	Pmax /Vf	TX Package Length (mm)	Pmax (V)	Vf (V)	Pmax /Vf	TX Package Gamma [0 a1 a2]	Pmax (V)	Vf (V)	Pmax /Vf
1	0.169	0.339	0.498	30	0.169	0.344	0.492	[0 1.734e-3 1.455e-4]	0.169	0.344	0.492
8	0.167	0.339	0.491	38.3	0.163	0.335	0.485	[0 1.942e-3 1.630e-4]	0.166	0.342	0.486
12	0.164	0.339	0.482	42	0.160	0.335	0.477	[0 2.254e-3 1.892e-4]	0.162	0.340	0.476
16	0.160	0.339	0.471	49	0.155	0.333	0.465	[0 2.601e-3 2.183e-4]	0.156	0.338	0.466
20	0.155	0.339	0.456	57	0.149	0.330	0.451	[0 3.121e-3 2.619e-4]	0.151	0.335	0.451

- ADS PRBS9 (by die rise time): ADS simulated PRBS9 pattern at TP2 by varying die rise time
- COM Pulse (by package length): COM simulated pulse at TP2 by varying package length
- COM Pulse (by Gamma): COM simulated pulse at TP2 by varying Gamma

Transmitter Characteristics investigation of effects of package length.



	COM Simulated PRBS9 @ TP2							
	Package Length 30mm	Package Length 38.3mm	Package Length 42mm	Package Length 49mm	Package Length 57mm	Units	SPEC (Table 92-6)	
Host Board Length	151					mm		
A_v	0.4					V		
Sigmae	5.919	8.695	8.586	8.111	7.757	mV		
Pmax (Linear fit pulse peak)	0.169	0.162	0.16	0.154	0.149	V		
SNDR (@ Sigman = 0)	29.116	25.431	25.38	25.594	25.657	dB	>=26dB	
Differential Peak to Peak Voltage	0.669	0.665	0.653	0.657	0.639	V	<=1.2V	
Vf (steady-state voltage)	0.341	0.334	0.333	0.331	0.328	V	0.34V=< Vf <=0.6V	
Pmax/Vf	0.495	0.486	0.479	0.467	0.453	N/A	>=0.45	

The value of Sigma e is changing significantly and is causing a fail in Tx_SNDR even with infinite Tx_SNR. Vf is also changing.

Transmitter Characteristics Investigations of Gamma change



	COM Simulated PRBS9 @ TP2							
	Package Gamma [0 1.734e-3 1.455e-4]	Package Gamma [0 1.942e-3 1.630e-4]	Package Gamma [0 2.254e-3 1.892e-4]	Package Gamma [0 2.601e-3 2.183e-4]	Package Gamma [0 3.121e-3 2.619e-4]	Units	SPEC (Table 92-6)	
Package Length	30						mm	
Host Board Length	151						mm	
A_v	0.4						V	
Sigmae	5.919	6.034	6.207	6.395	6.668	mV		
Pmax (Linear fit pulse peak)	0.169	0.166	0.162	0.157	0.151	V		
SNDR (@ Sigman = 0)	29.116	28.796	28.332	27.824	27.091	dB	>=26dB	
Differential Peak to Peak Voltage	0.669	0.665	0.659	0.653	0.644	V	<=1.2V	
Vf (steady-state voltage)	0.341	0.34	0.338	0.336	0.333	V	0.34V=< Vf <=0.6V	
Pmax/Vf	0.495	0.488	0.479	0.469	0.454	N/A	>=0.45	

The value of Sigma e is changing but not as badly. Vf is also changing a little (which should change Av)

Transmitter Characteristics with Gaussian Tx filter



	COM Simulated PRBS9 @ TP2							
	Gaussian Risetime 1ps	Gaussian Risetime 8ps	Gaussian Risetime 12ps	Gaussian Risetime 16ps	Gaussian Risetime 18ps	Units	SPEC (Table 92-6)	
Package Length	30					mm		
Host Board Length	151					mm		
A_v	0.4					V		
Sigmae	5.918	5.904	5.889	5.873	5.865	mV		
Pmax (Linear fit pulse peak)	0.169	0.165	0.161	0.156	0.153	V		
SNDR (@ Sigman = 0)	29.113	28.944	28.74	28.474	28.322	dB	>=26dB	
Differential Peak to Peak Voltage	0.669	0.668	0.667	0.666	0.666	V	<=1.2V	
Vf (steady-state voltage)	0.341	0.342	0.342	0.342	0.342	V	0.34V=< Vf <=0.6V	
Pmax/Vf	0.495	0.484	0.472	0.456	0.448	N/A	>=0.45	

Both Sigma e and Vf are stable. Recommend using this method to degrade Pmax/Vf

TX FFE Determine Tap weights applicable to reference equalizer.



	FCI 3m 26AWG			TE 3m 25AWG 15.25dB			FCI 3m 25AWG 15.35dB			FCI 3m 26AWG 15.96dB			FCI 3m 26AWG 15.99dB		
Gaussian Filter Risetime (pS)	TX LE Taps			TX LE Taps			TX LE Taps			TX LE Taps			TX LE Taps		
1	-0.12	0.64	-0.24	-0.14	0.66	-0.2	-0.12	0.66	-0.22	-0.12	0.64	-0.24	-0.12	0.64	-0.24
8	-0.12	0.62	-0.26	-0.12	0.64	-0.24	-0.12	0.64	-0.24	-0.12	0.62	-0.26	-0.12	0.62	-0.26
12	-0.12	0.62	-0.26	-0.12	0.62	-0.26	-0.12	0.64	-0.24	-0.12	0.62	-0.26	-0.12	0.62	-0.26
16	-0.12	0.62	-0.26	-0.14	0.62	-0.24	-0.12	0.62	-0.26	-0.14	0.62	-0.24	-0.14	0.62	-0.24
18	-0.16	0.62	-0.22	-0.14	0.62	-0.24	-0.14	0.62	-0.24	-0.14	0.62	-0.24	-0.14	0.62	-0.24

TX LE taps were obtained through COM optimization

Transmitter Characteristics @ TP2 w/ TX Equalization:



	COM Simulated PRBS9 @ TP2							
Cpre	0	-0.12	-0.12	-0.12	-0.14	-0.16	Units	SPEC (Table 92-6)
Cmain	0	0.66	0.64	0.62	0.62	0.62		
Cpost	0	-0.22	-0.24	-0.26	-0.24	-0.22		
Package Length	30						mm	
Host Board Length	151						mm	
Gaussian Filter Risetime	8						pS	
Sigmae	5.904	1.831	1.599	1.386	1.42	1.459	mV	
Pmax (Linear fit pulse peak)	0.165	0.095	0.092	0.088	0.087	0.086	V	
SNDR (@ Sigman = 0)	28.944	34.324	35.153	36.032	35.725	35.395	dB	>=26dB
Differential Peak to Peak Voltage	0.668	0.279	0.265	0.254	0.253	0.256	V	<=1.2V
Vf (steady-state voltage)	0.342	0.11	0.097	0.083	0.083	0.083	V	0.34V=< Vf <=0.6V
Pmax/Vf	0.484	0.866	0.948	1.058	1.048	1.039	N/A	>=0.45
Sigman (for SNDR 26dB@TP2)	5.814	4.41	4.30	4.176	4.113	4.05	mV	
TXSNR (to achieve sigman above)	29.078	26.691	26.563	26.454	26.49	26.53	dB	

Although TX FIR reduces Sigma e sigma n still has to drop a little to pass Tx_SNDR with the equalization on.



Backup – Cables used

TE 3m 25AWG 15.25dB Loss Cable (tracy_3by_01_0715.pdf)

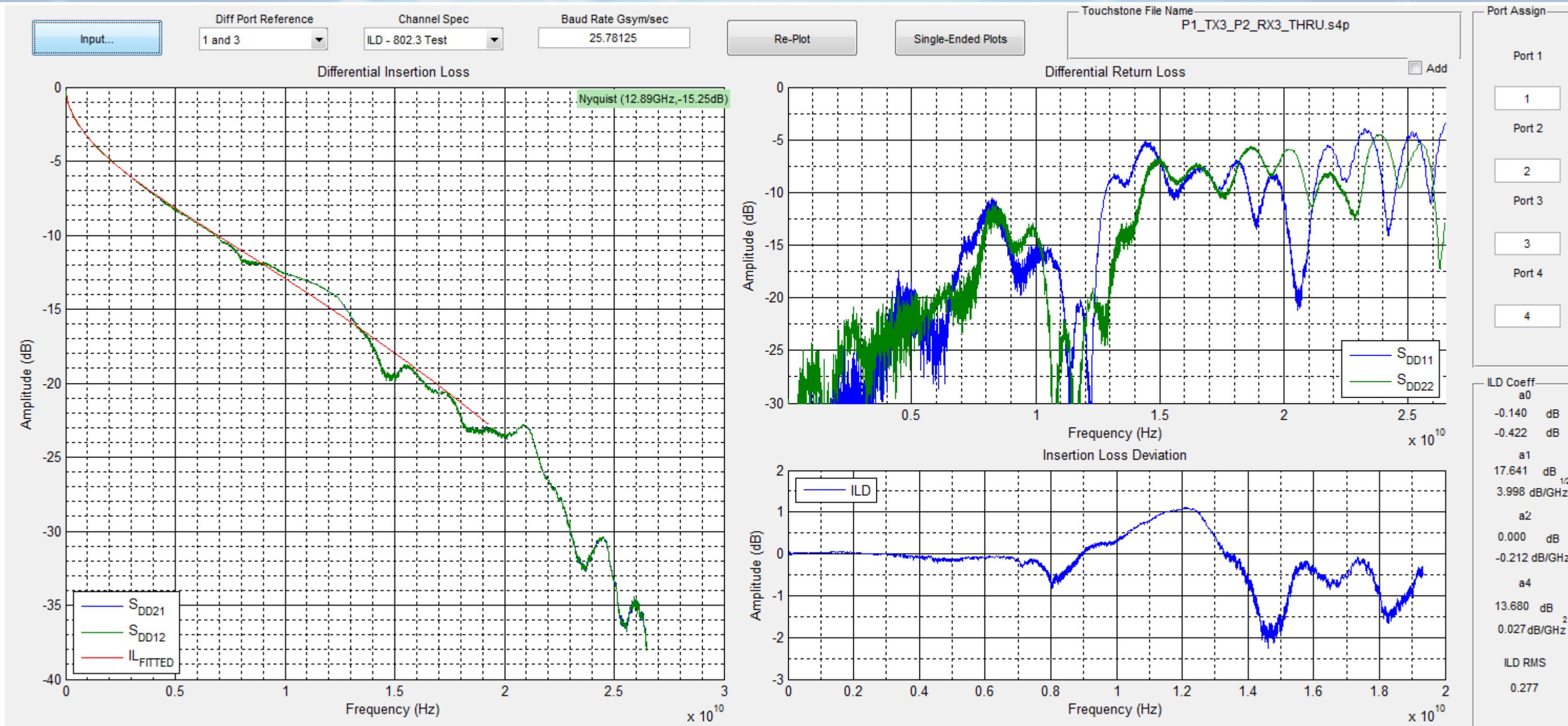

TE 3m 25AWG 15.35dB Loss Cable (tracy_3by_01_0715.pdf)

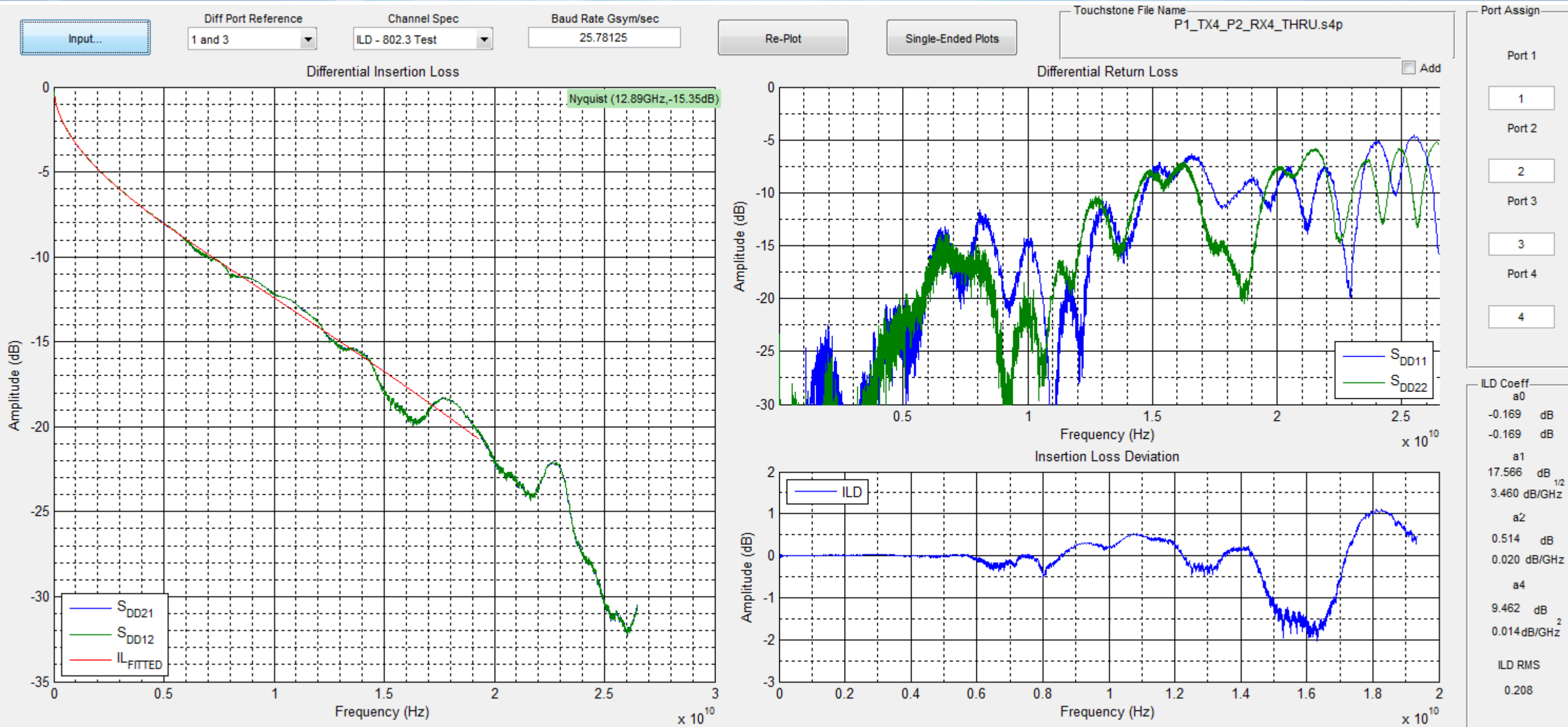

TE 3m 26AWG 15.96dB Loss Cable (tracy_3by_01_0715.pdf)

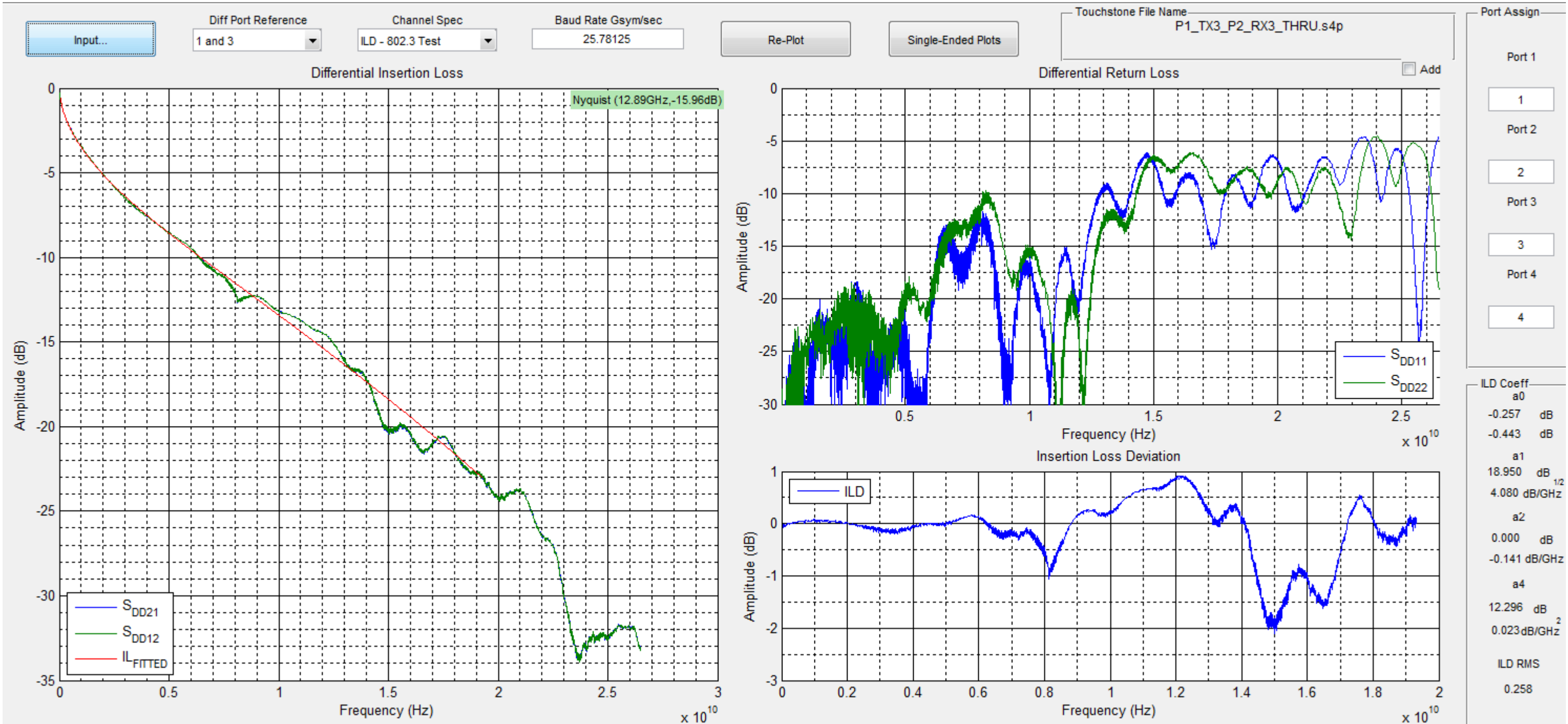

TE 3m 26AWG 15.99dB Loss Cable (tracy_3by_01_0715.pdf)

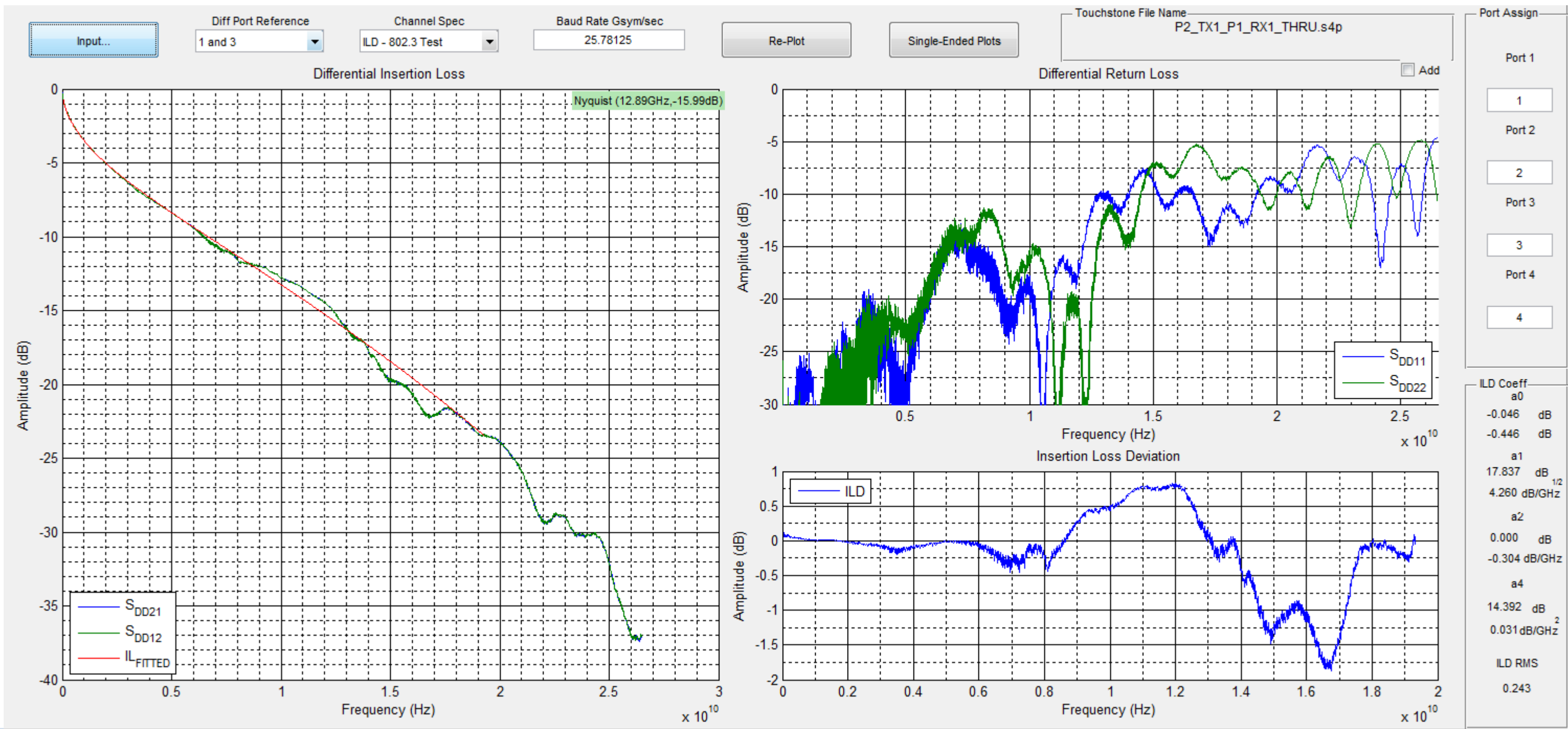

FCI 3m 26AWG 17.59dB Loss Cable (zambell_090215_25GE_adhoc-v2.pdf)

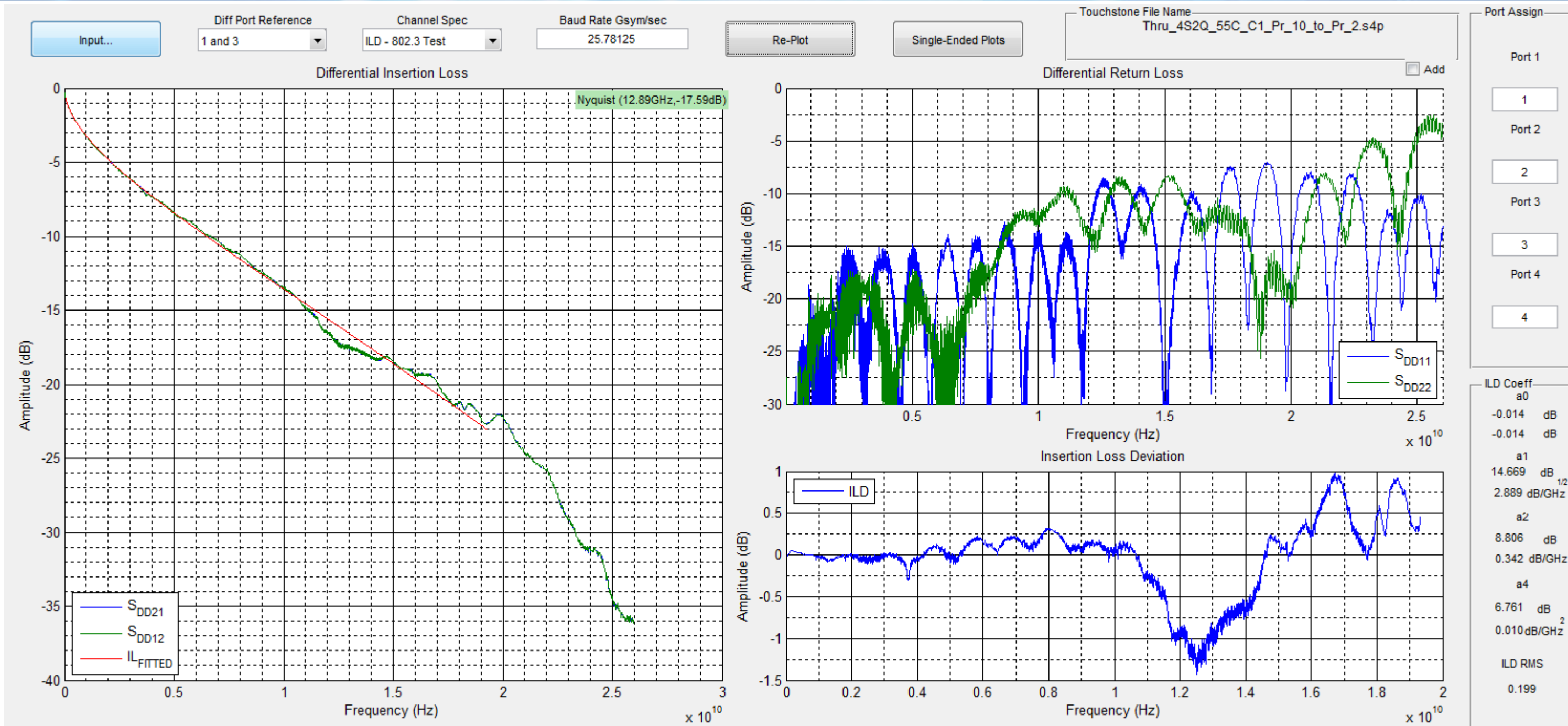

TE 3m 26AWG QSFP Cable: P2_TX2 THRU (shanbhag_020415_25GE_adhoc_v2.pdf)

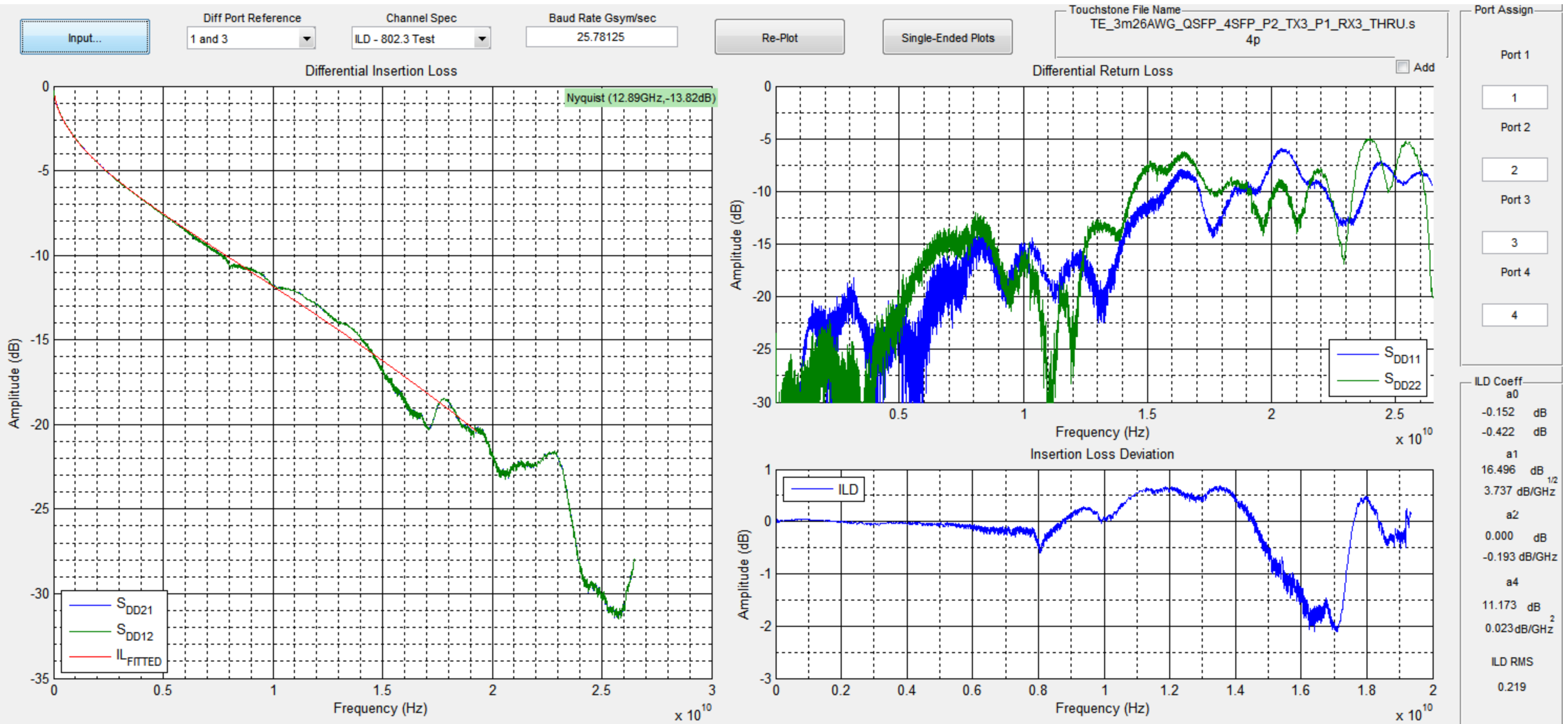

TE 3m 28AWG QSFP Cable: P2_TX2 THRU (shanbhag_020415_25GE_adhoc_v2.pdf)

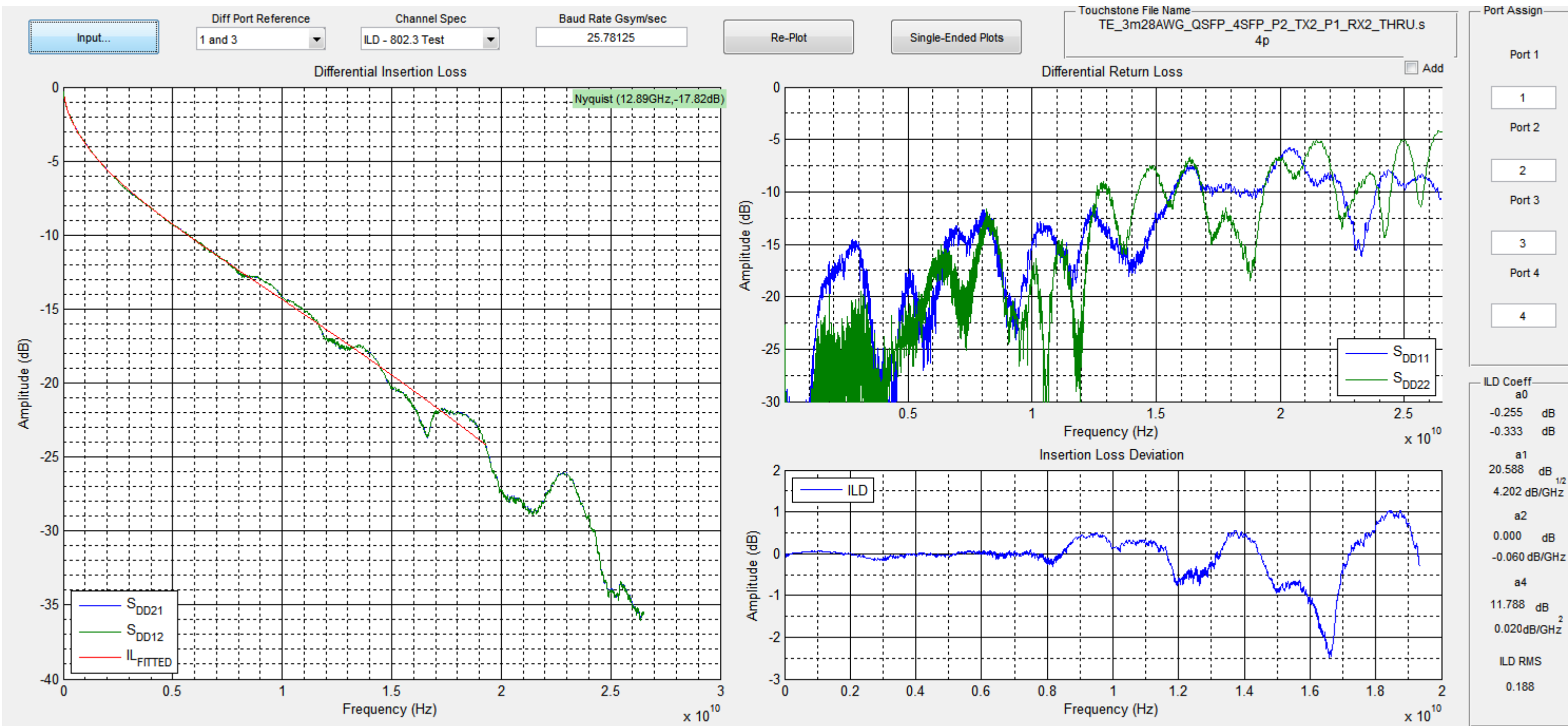

TE 3m 30AWG QSFP Cable: P2_TX3 THRU (shanbhag_020415_25GE_adhoc_v2.pdf)

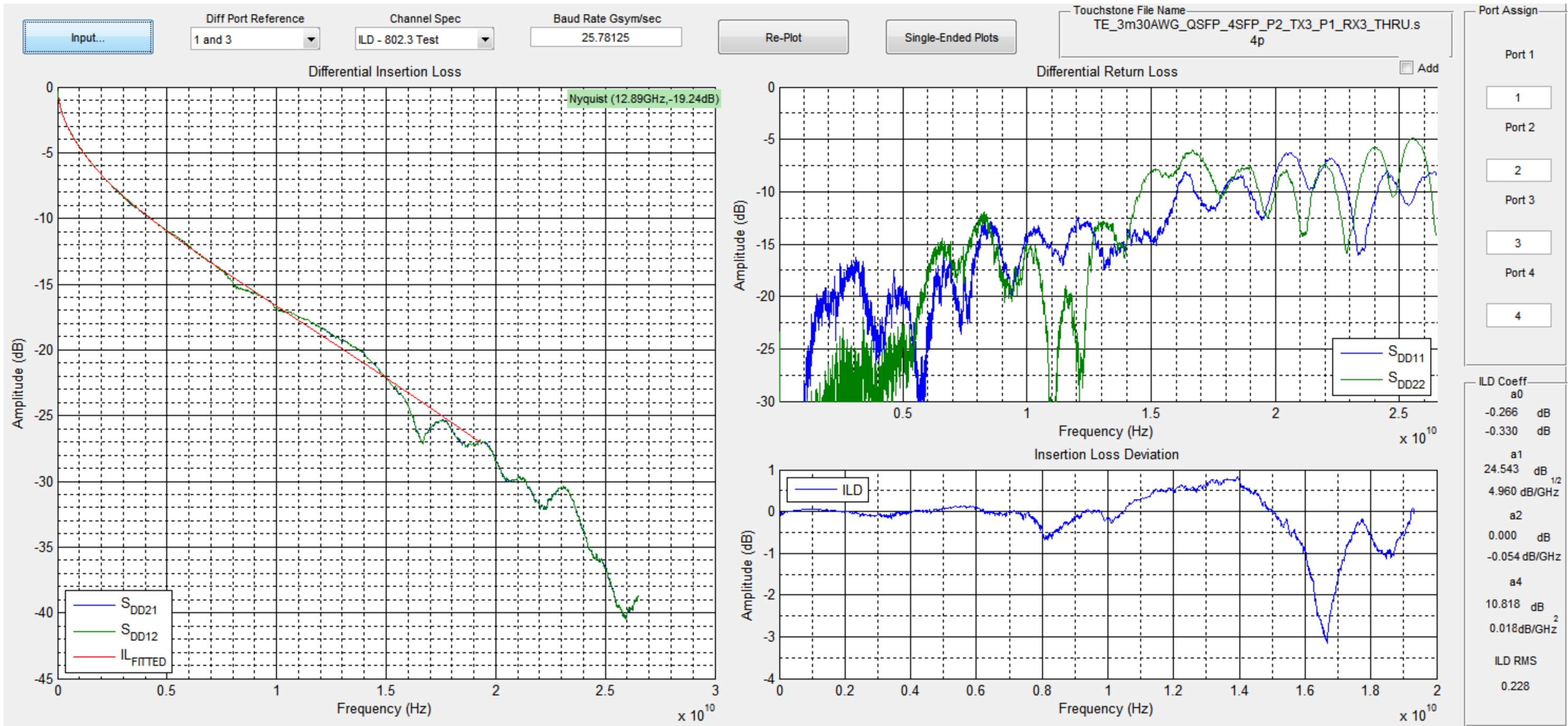

TE 5m 26AWG QSFP Cable: P2TX THRU

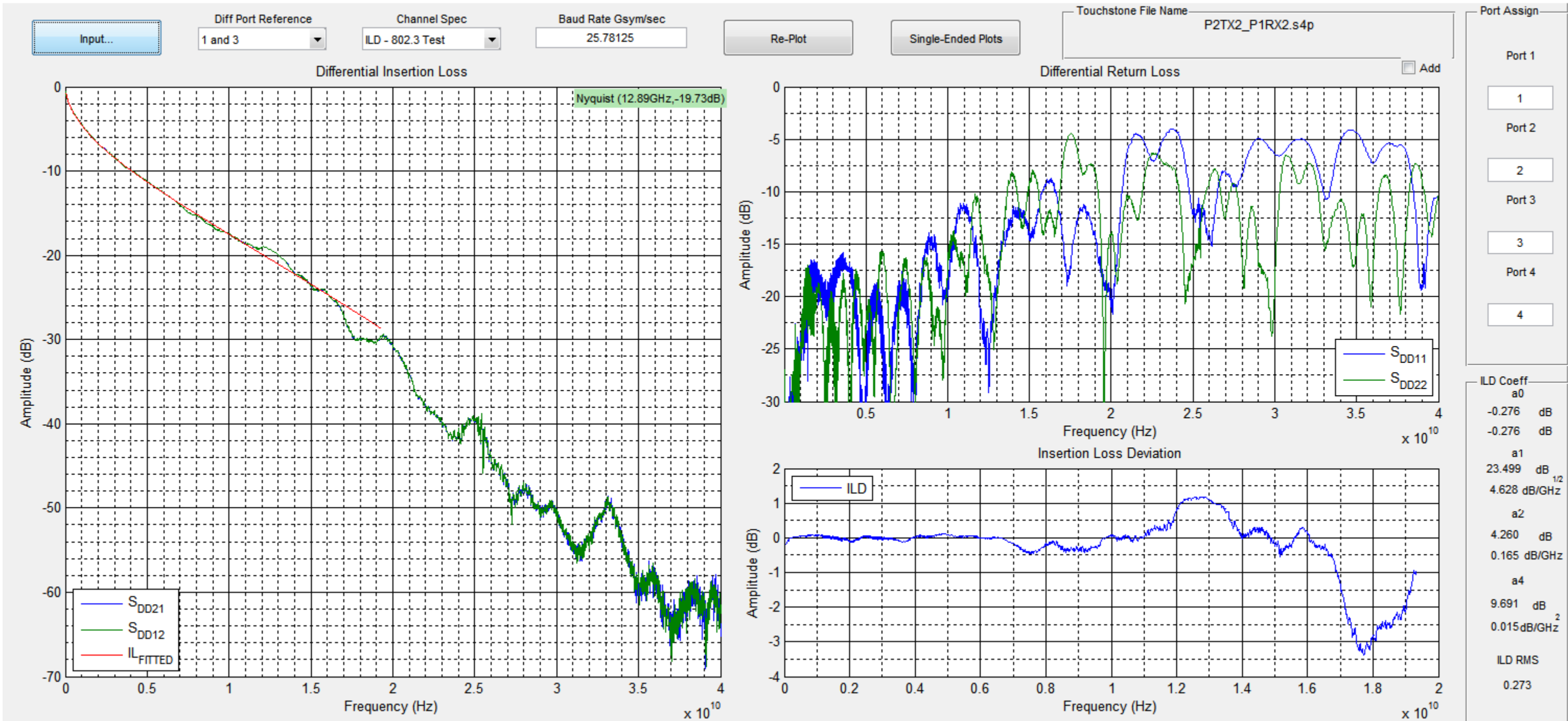



Backup - Backplane Channels used

Mellitz 35dB FR4 Channel (mellitz_3bj_01_0713.pdf)

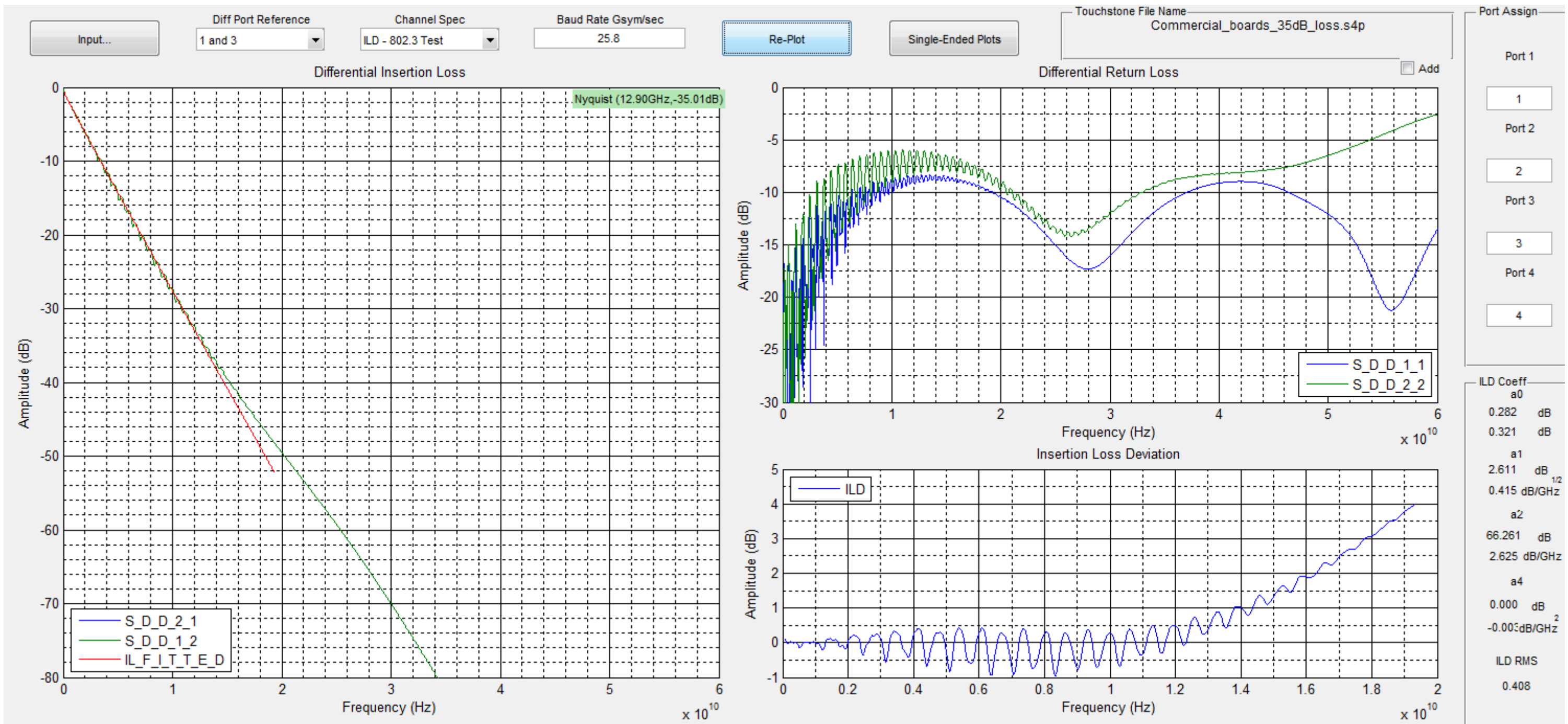

Beth 32dB Loss Channel (kochuparambil_3bj_01_0913.pdf)

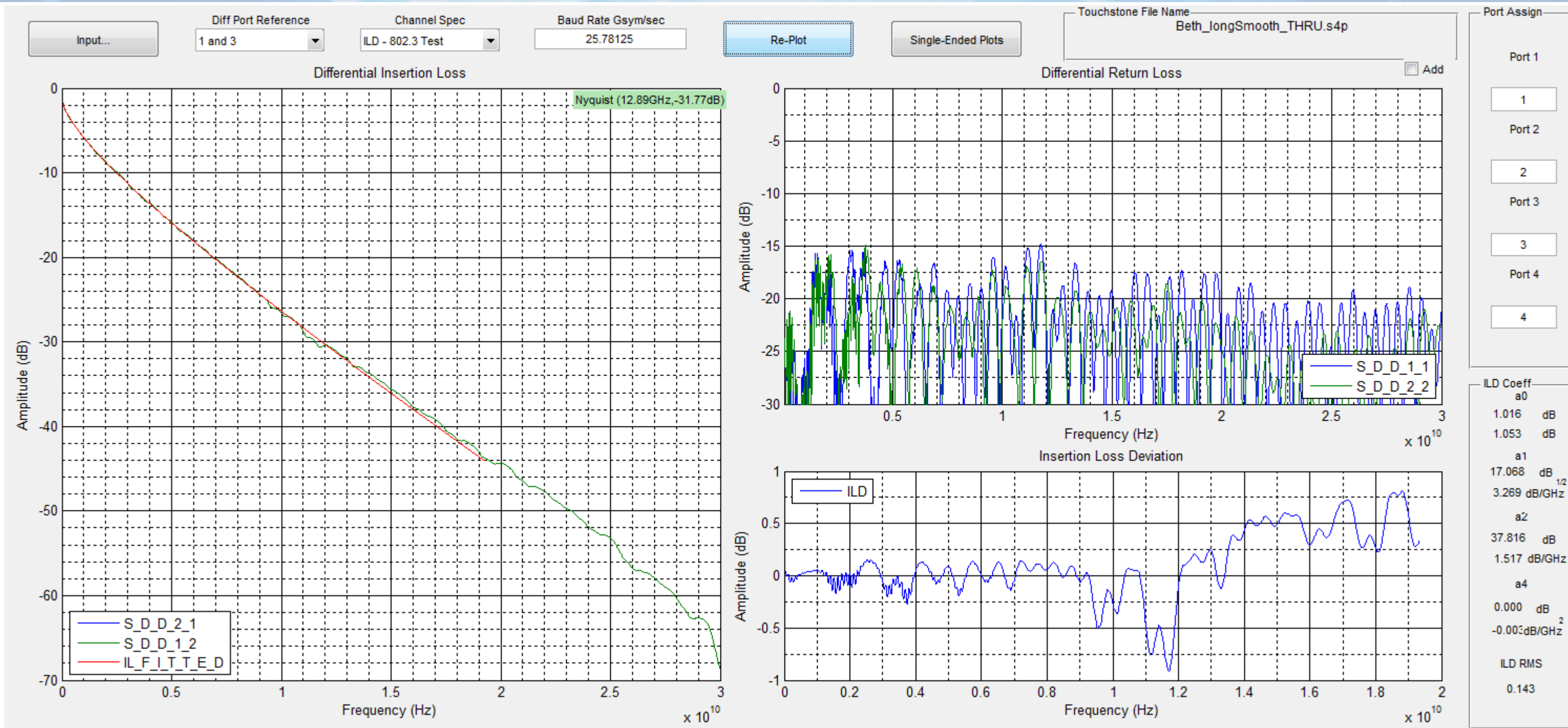

Tracy 30dB Loss Channel (tracy_3bj_01_0713.pdf)

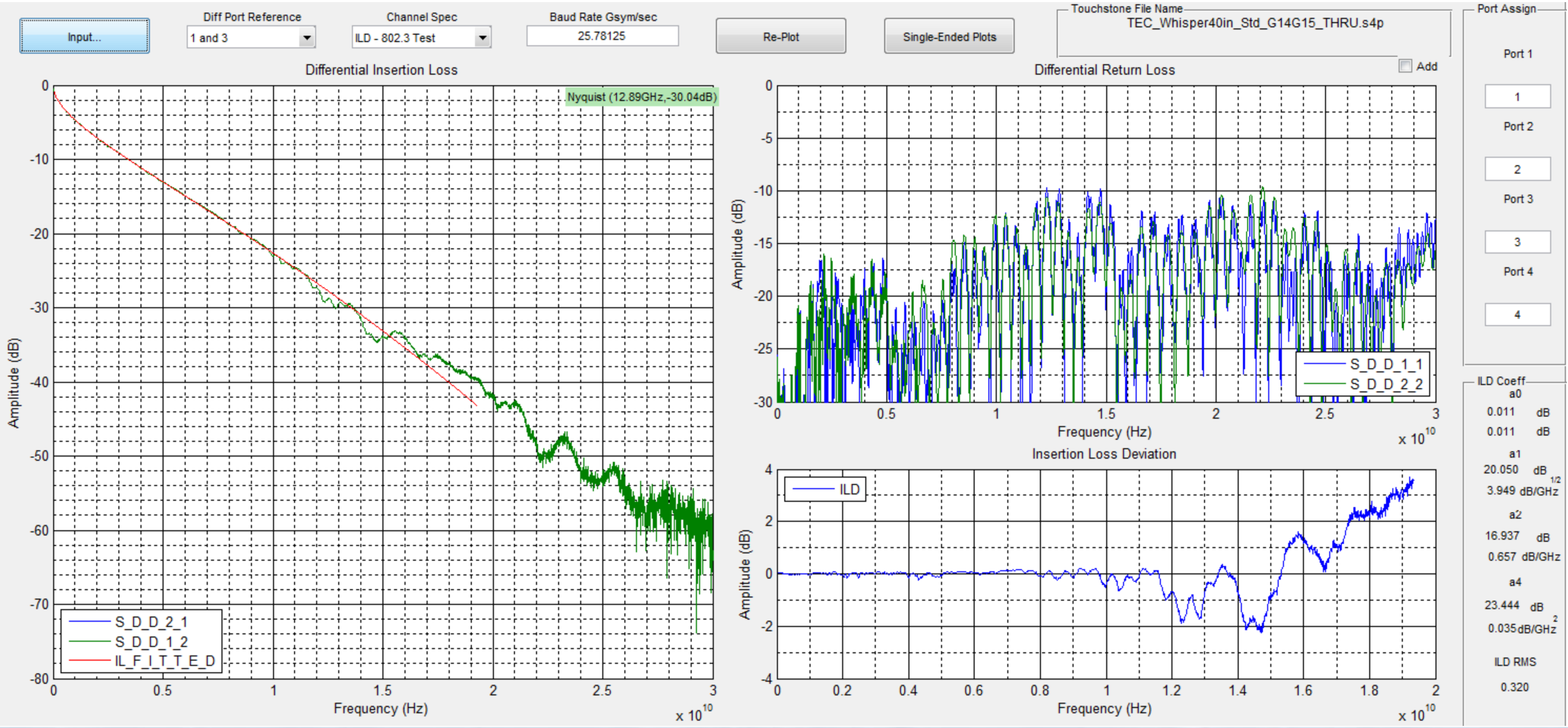

Shanbhag 18.7dB Loss Channel (shanbhag_03_0411.pdf)

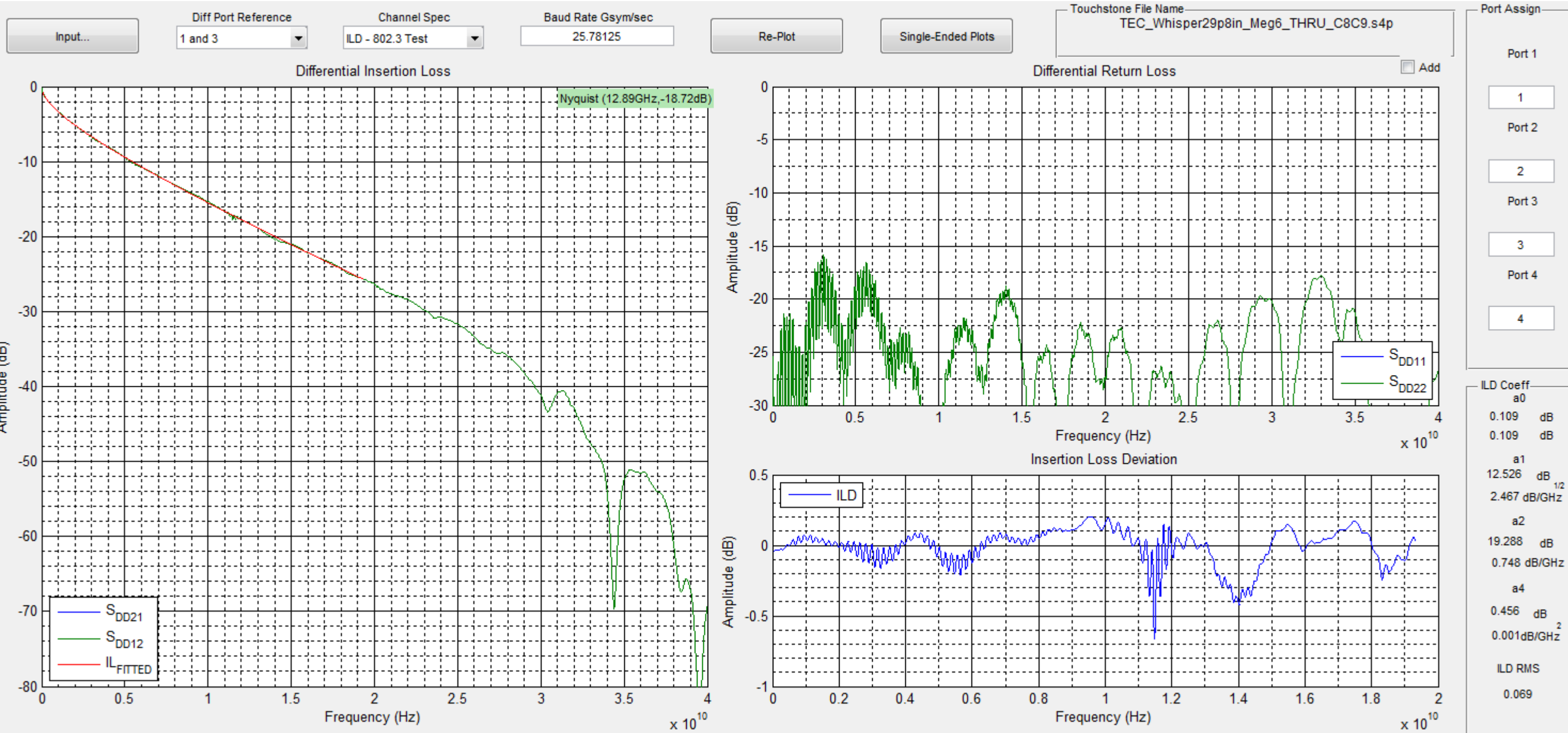



Backup (from Dudek_3by_01_0116)

Channel Block Diagram for simulation at TP0a

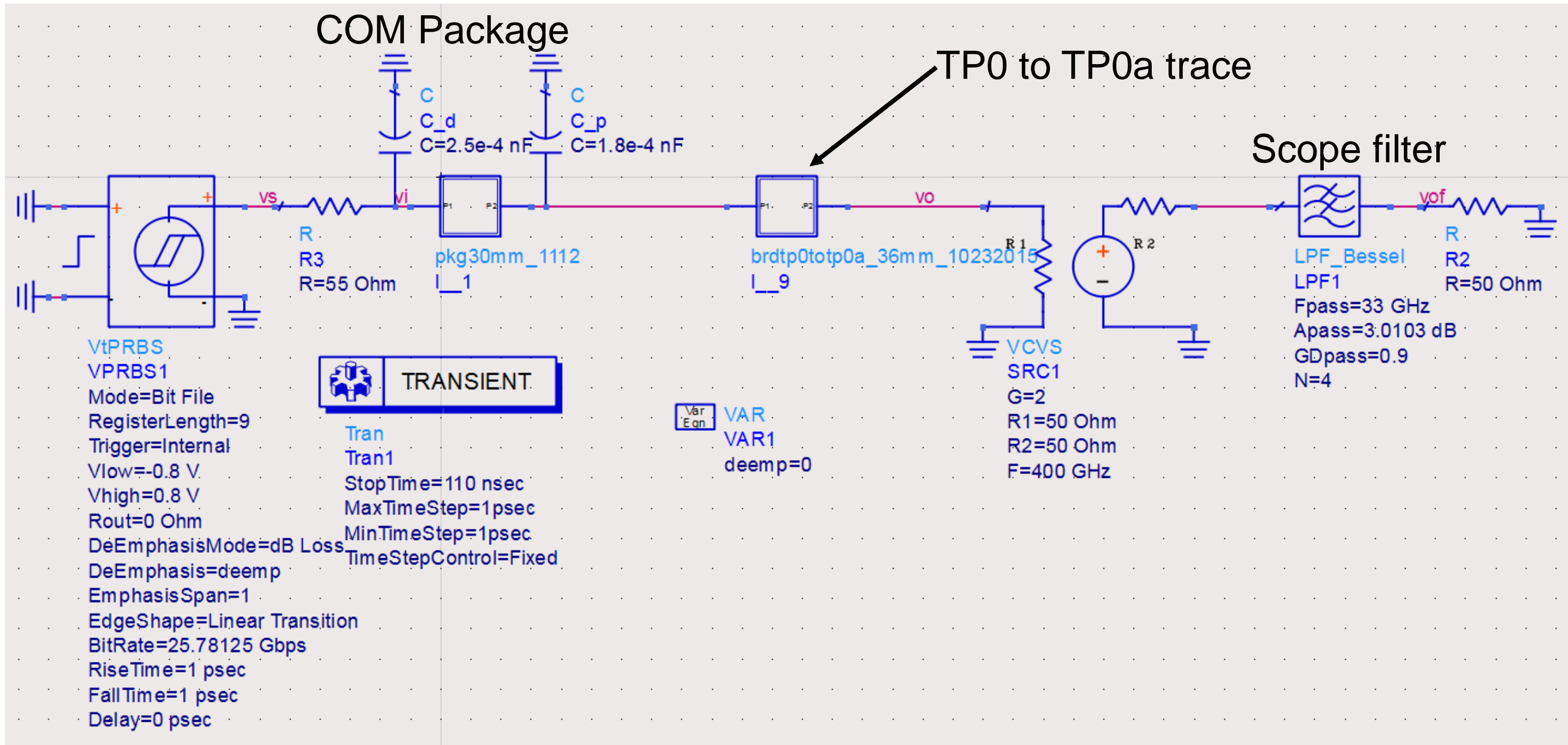

TP0 to TP0a Insertion loss

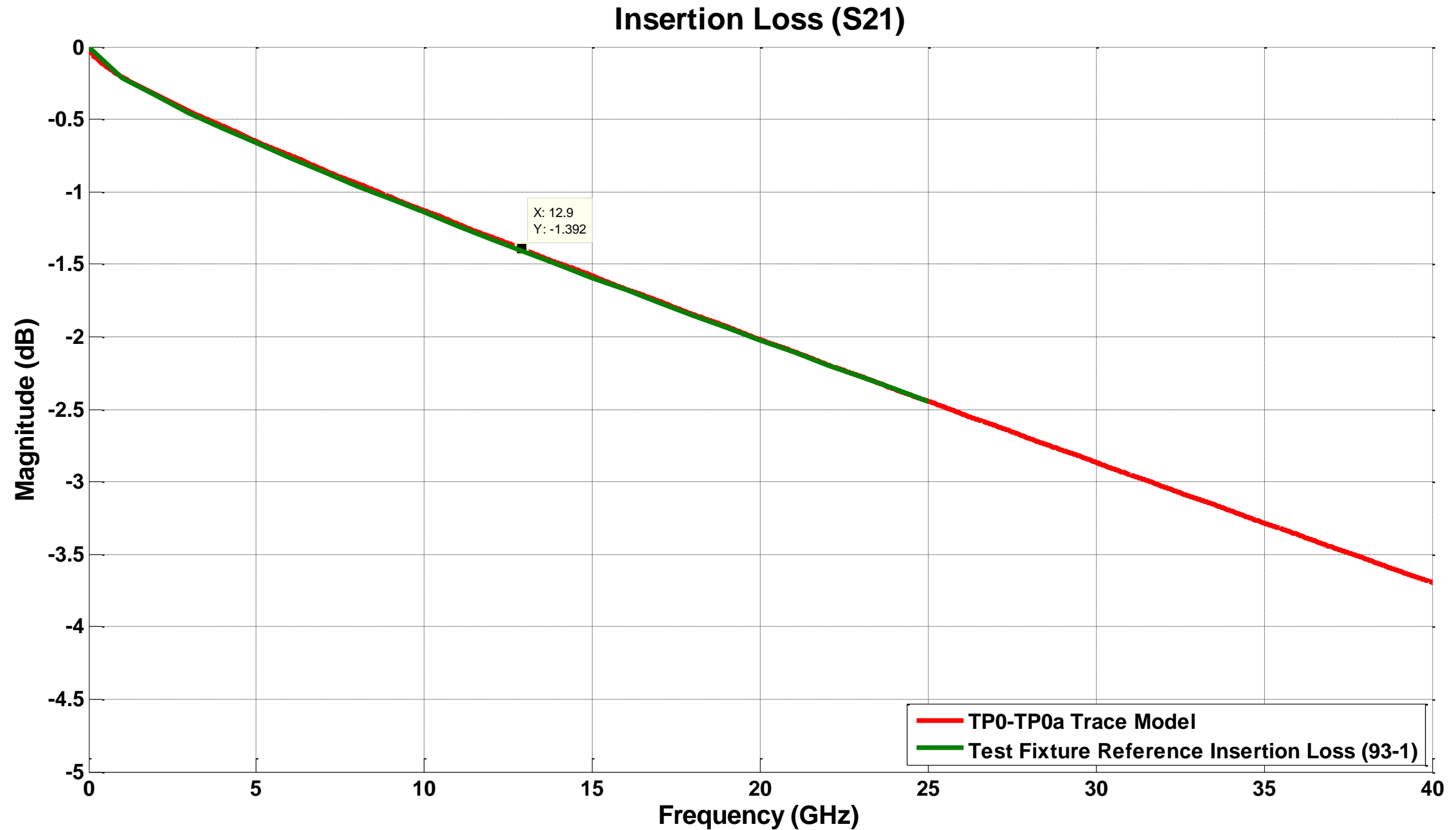

Tp0 to Tp0a Return loss

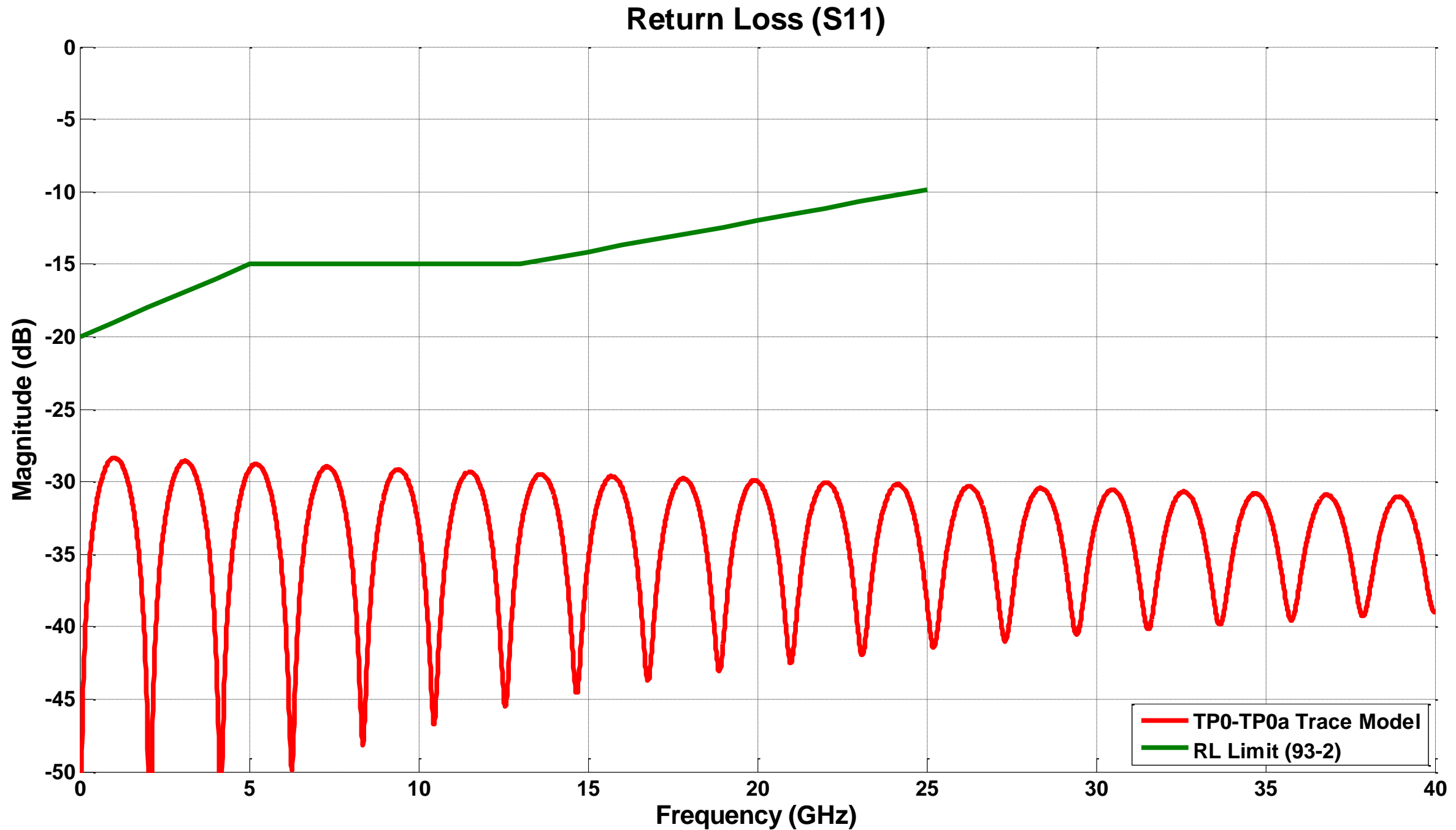

Channel Block Diagram for simulation at TP2

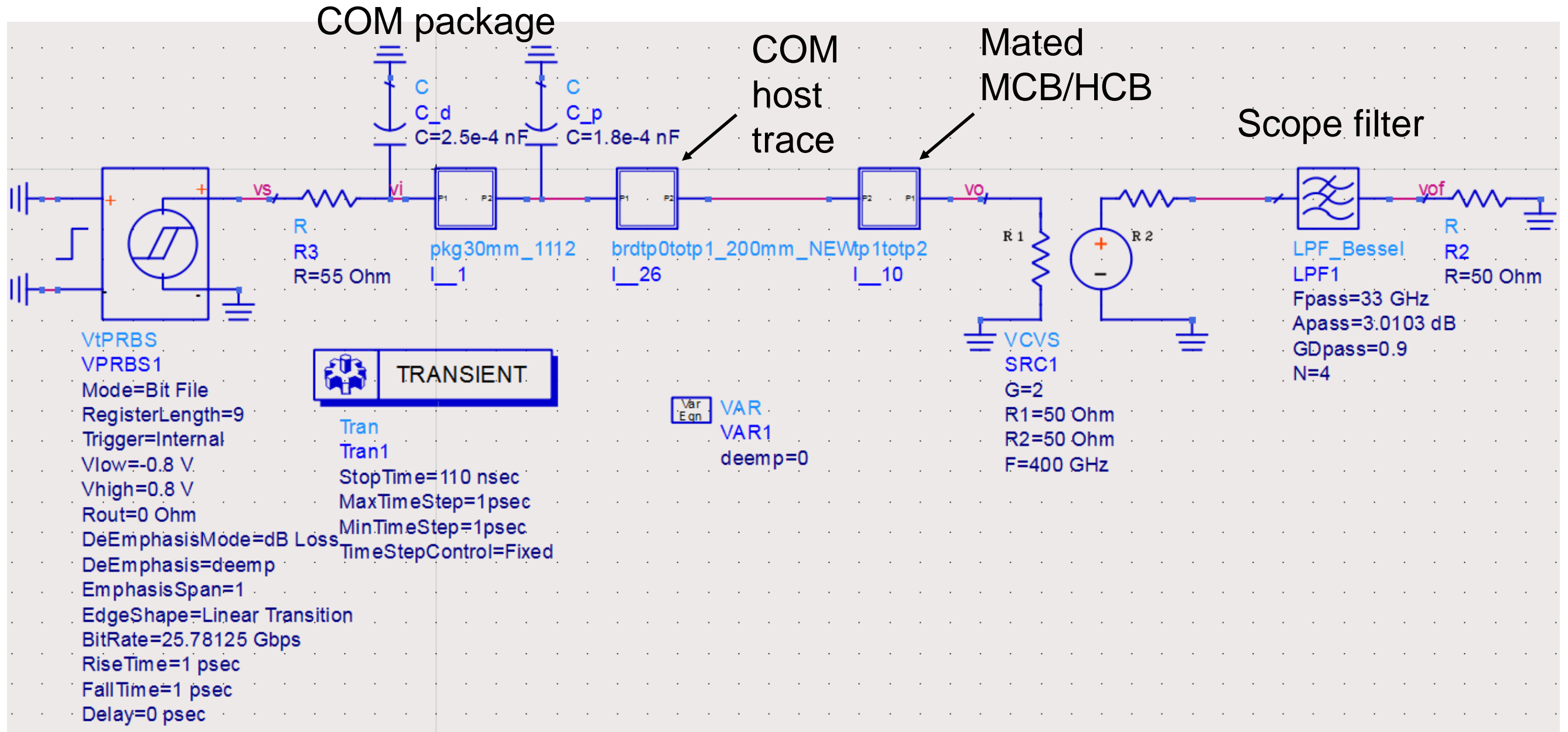

Tp1 to Tp2 Insertion loss (mated MCB/HCB)

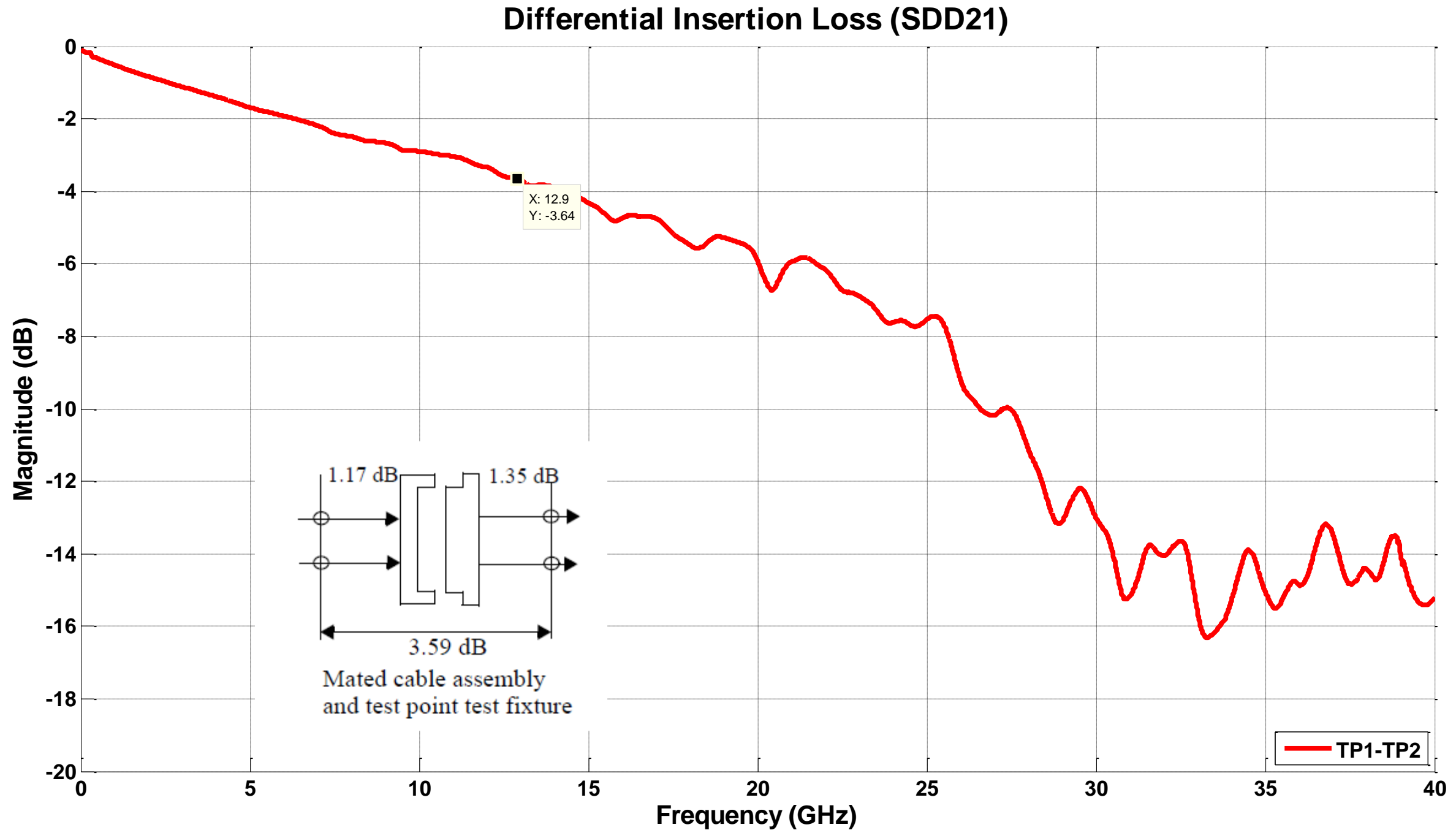

Tp1 to Tp2 Return loss (mated MCB/HCB)

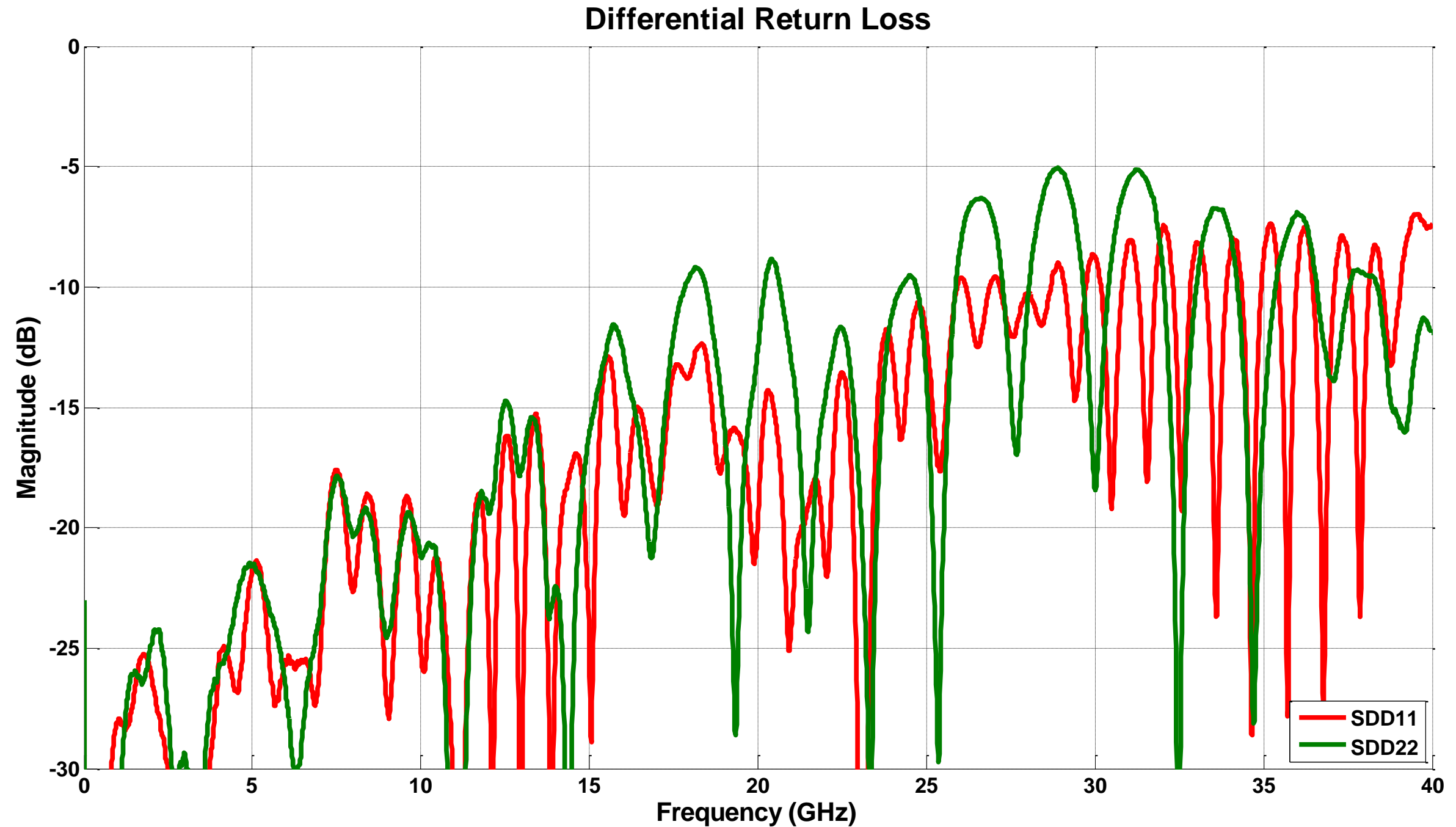

Results



	TP0a					TP2					
	Rise Time 1ps [20% to 80%]	Rise Time 8ps [20% to 80%]	Rise Time 12ps [20% to 80%]	Rise Time 20ps [20% to 80%]	SPEC (Table 93-4)	Rise Time 1ps [20% to 80%]	Rise Time 8ps [20% to 80%]	Rise Time 12ps [20% to 80%]	Rise Time 20ps [20% to 80%]	Units	SPEC (Table 92-6)
Host Board Length	Meet IL defined by Equation (93-1)					151				mm	
ADS PRBS Source Peak Voltage	0.8					0.8				V	
Sigmae	3.279	3.223	3.207	3.226		6.416	6.419	6.410	6.374	mV	
Pmax (Linear fit pulse peak)	0.292	0.286	0.279	0.257		0.169	0.167	0.164	0.155	V	
SNDR (@ Sigman = 0)	38.999	38.962	38.782	38.033	>=27dB	28.415	28.284	28.140	27.713	dB	>=26dB
Differential Peak to Peak Voltage	0.755	0.753	0.752	0.747	<=1.2V	0.676	0.675	0.674	0.672	V	<=1.2V
Vf (steady-state voltage)	0.363	0.363	0.363	0.363	0.4V=< Vf <=0.6V	0.339	0.339	0.339	0.339	V	0.34V=< Vf <=0.6V
Pmax/Vf	0.806	0.789	0.769	0.710	>=0.71	0.498	0.491	0.482	0.456	N/A	>=0.45
Sigman (for SNDR 27dB@TP0a for SNDR 26dB@TP2)	12.633	12.362	12.032	11.026		5.534	5.339	5.116	4.432	mV	
TXSNR (to achieve sigman above)	27.283	27.286	27.298	27.357		29.700	29.883	30.099	30.870	dB	

Conclusions and suggested change (from Dudek_3by_01_0116)

- The P_{max}/V_f ratio allowed by both the backplane and copper cable specifications at TP0a and at TP2 is significantly lower than provided by the COM transmitter which uses the very fast risetime, creating a hole in the spec.
- These specifications allow a 20ps on die risetime even with the worst case long package. This is unnecessarily relaxed.
- Suggested change is to increase the P_{max}/V_f ratio from 0.71 to 0.78 at TP0a and from 0.45 to 0.49 at TP2. (equivalent to approx. 10ps die risetime with the worst case package).

Note.

- Clause 92 of 802.3bj Tx specs at TP2 required a higher value of Tx_SNR than was effectively used in COM which somewhat compensates for this.
- For the CA-25G-N cable we have reduced the amount of noise (increased Tx-SNR) used in COM to get closer to the Tx noise that the Tx specs allows, removing that compensation.