

**bright
house**
NETWORKS



P802.3CA PCS/RS

CONTACT:

MAREK HAJDUCZENIA

NETWORK ARCHITECT, PRINCIPAL ENGINEER

EMAIL: MAREK.HAJDUCZENIA@MYBRIGHTHOUSE.COM

Summary / Outline

- Per [ngepon 1511 work areas draft.xlsx](#), there are several areas of interest in PCS sublayer definitions:
 - FEC selection
 - Frame coding based on 10G-EPON
 - IDLE insertion/deletion function
 - Scrambler
 - Data Detector + Synchronizer
- This presentation looks into existing definitions for 10G-EPON and suggests first order approximations for some of these functions.
 - Working assumption: [ngepon 1511 hajduczenia 3.pdf, page 8](#) is considered as baseline for NG-EPON architecture going forward.
- Specific items to look at in NG-EPON in more detail:
 - New more powerful stream-based FEC (per [effenberger 3ca 2 0316.pdf](#))
 - Number of broadcast LLIDs to be reserved in RS

Line Coding (1)

- 64B/66B, with sync-header suppression for FEC calculation

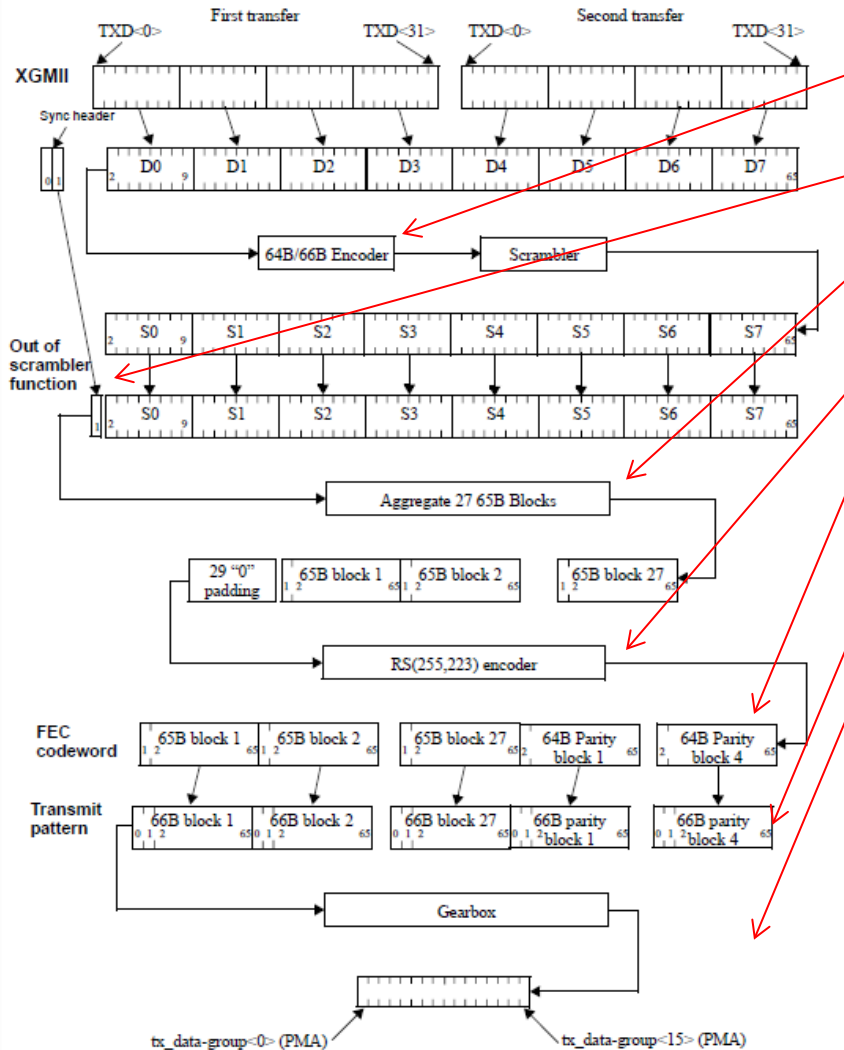

Figure 76-13—PCS Transmit bit ordering

Standard 64B/66B encoder defined in Clause 49

Sync header suppression: 65B blocks created from 64B data blocks

Aggregate 64B blocks to input into FEC encoder

Encode data with suppressed sync header and 0-based padding

Only data is received on output, 0-based padding is discarded

Recreate 66B blocks by adding extra XORed sync-header bit

Transmit to PMA and then into MDI

Line encoding interleaved with scrambling and FEC encoding in 10G-EPON.
Reverse data flow in receive direction!

Line Coding (2)

- In 10G-EPON, 64B/66B line encoding is applied to all data received from XGMII
- Proposal for NG-EPON:
 - Adopt per-lane 64B/66B line encoding with sync-header suppression for FEC calculation, defined for 10G-EPON, as baseline proposal for NG-EPON
 - Each data lane in NG-EPON is operated independently, i.e., line encoding, FEC encoding, etc. is done independently from other data lanes.
 - Details are described in the following subclauses:
 - Transmit direction:
76.3.2.2, parts of 76.3.2.4 (excluding FEC encoding process)
 - Receive direction:
parts of 76.3.3.3 (excluding FEC decoding process), 76.3.3.6

Scrambler

- In 10G-EPON, all data is scrambled using scrambler/descrambler pair defined in 49.2.6 / 49.2.10, respectively.
- Proposal for NG-EPON:
 - Adopt per-lane scrambler / descrambler, defined for 10G-EPON, as baseline proposal for NG-EPON
 - Each data lane in NG-EPON is operated independently, i.e., scrambling and descrambling is done independently from other data lanes.
 - Details are described in the following subclauses:
 - Transmit direction: 76.3.2.3
 - Receive direction: 76.3.3.5

IDLE Insertion / Deletion (1)

- In 10G-EPON, IDLE Insertion / Deletion function is responsible for adapting MAC data stream to match the effective PHY throughput.
- In 10G-EPON, transmit direction
 - IDLE deletion function (76.3.2.1) removes extra IDLE characters to de-rate MAC data stream to effective PHY throughput
 - Details defined in OLT and ONU state diagrams in 76.3.2.1.5
 - Operation relies only on size of **FEC data / parity components**
- In 10G-EPON, receive direction
 - IDLE insertion function (76.3.3.7) fills in gaps in MAC data stream created after removal of FEC parity data
 - Details defined in OLT / ONU state diagram in 76.3.3.7.5
 - Operation relies only on presence / absence of data from FEC decoder, independent of FEC code parameters

IDLE Insertion / Deletion (2)

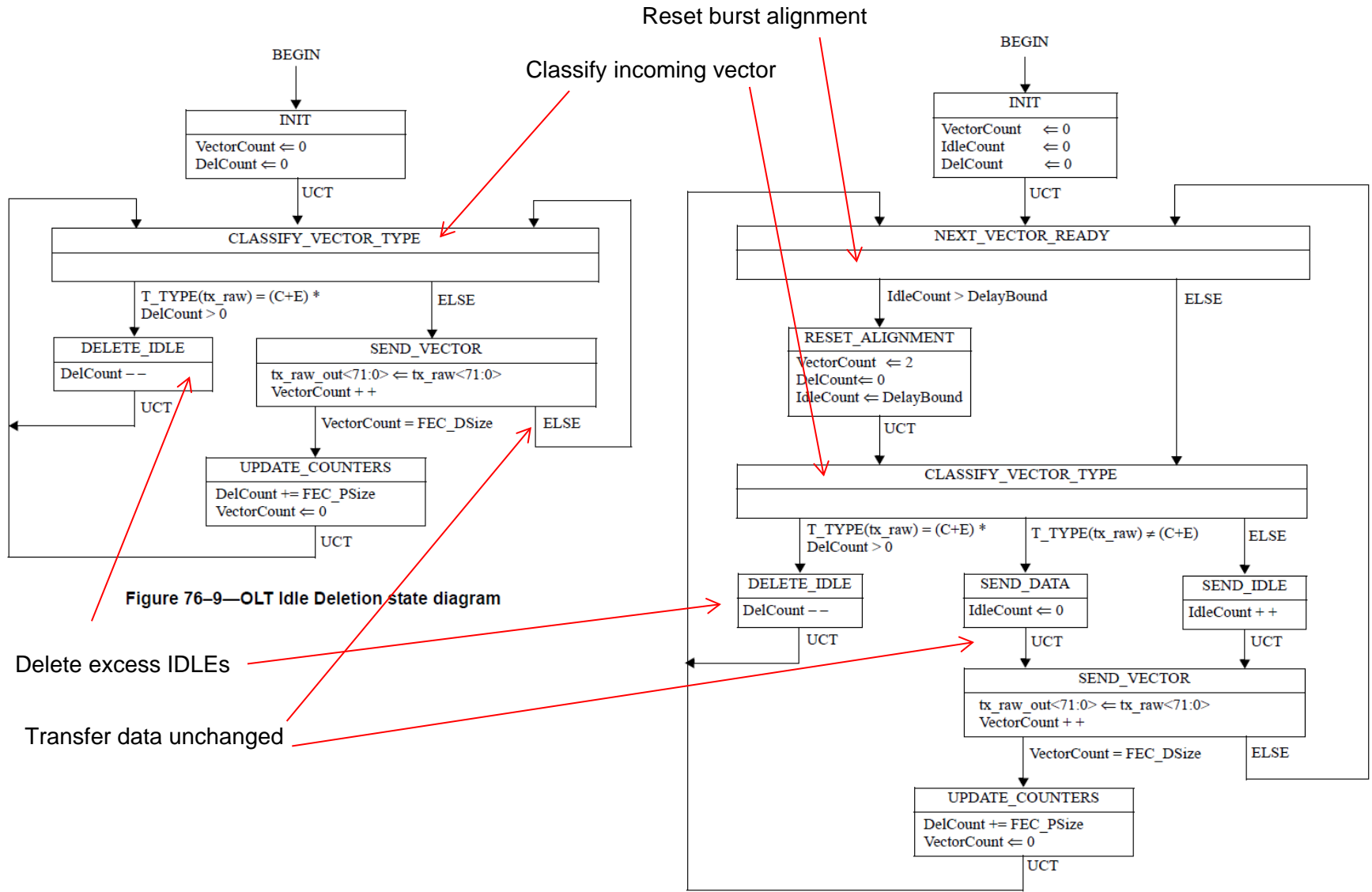

Figure 76-9—OLT Idle Deletion state diagram

Figure 76-10—ONU Idle Deletion state diagram

IDLE Insertion / Deletion (3)

send LBLOCK_R to XGMII when no data from PCS

send data from FIFO_II when data from PCS present

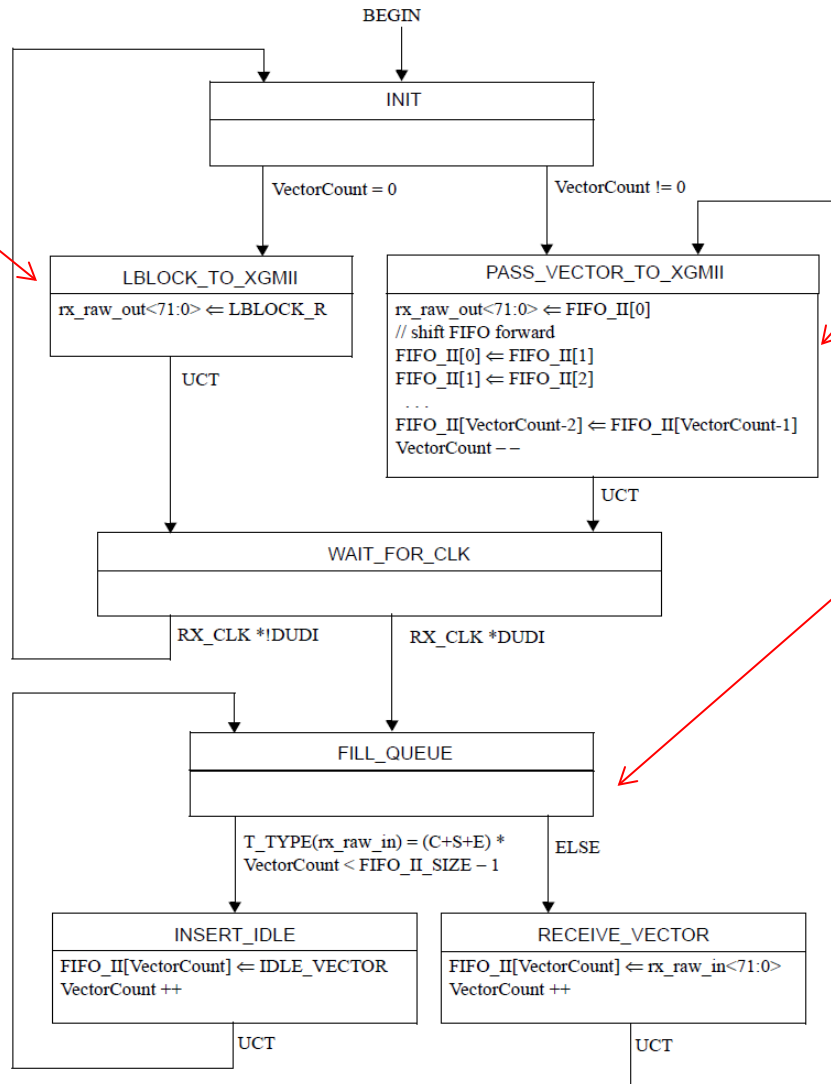

fill in FIFO_II when FEC Decoder signals it is done decoding next FEC codeword

Figure 76-23—PCS Idle Insertion

IDLE Insertion / Deletion (4)

- Proposal for NG-EPON:
 - Adopt per-lane IDLE deletion / insertion functions, defined for 10G-EPON, as baseline proposal for NG-EPON
 - Each data lane in NG-EPON is operated independently, i.e., IDLE insertion and deletion is done independently from other data lanes.
 - Details are described in the following subclauses:
 - Transmit direction: 76.3.2.1
 - Receive direction: 76.3.3.7
- Additional points to consider for NG-EPON
 - Updates to state diagram constants will be needed if FEC code different than RS(255,223) is selected for NG-EPON
 - No changes to individual data blocks needed, if 25GMII (per Clause 106) is used, the MII structure is the same as XGMII, just operated at higher clock rates (390.625 MHz \pm 100ppm, see P802.3by 106.3)

FEC (1)

- In 10G-EPON, RS(255,223) FEC is used
 - 32 octets of FEC parity is added every 223 octets of data
- In transmit direction (per 76.3.2.4, see slide 2 for details)
 - FEC encoder accumulates 27 x 66-bit data blocks from XGMII
 - First sync header bit is dropped before feeding data into encoder
 - 27 x 65-bit blocks + 29 padding zeros are fed into FEC encoder
 - Only data + parity is transmitted; zero padding is discarded
- In receive direction (per 76.3.3.3)
 - Once incoming data stream is synchronized, FEC decoder processes incoming data on per FEC codeword basis
 - Decoding failures may be signaled by higher layers by setting specific value of sync header bits, invalidating whole received codeword.

FEC (2)

- Proposal for NG-EPON:
 - Adopt per-lane RS(255,223) FEC, defined for 10G-EPON, as baseline proposal for NG-EPON
 - Each data lane in NG-EPON is operated independently, i.e., FEC encoding and decoding is done independently from other data lanes.
 - Details are described in the following subclauses:
 - Transmit direction: 76.3.2.4
 - Receive direction: 76.3.3.3
- Additional points to consider for NG-EPON
 - RS(255,223) adds constant (stream-based FEC) overhead of ~14%. A lower overhead FEC might be welcome for NG-EPON.
 - [effenberger_3ca_2_0316.pdf](#) provides overview of other FEC code candidates for 10G-EPON, with improved gain, complexity, and overhead.

Data Detector / Synchronizer (1)

- In 10G-EPON, Data Detector present in Tx direction
 - Forms sufficient transmit delay to allow ONU insert burst markers, synchronization patterns, etc., and tells ONU when to start shutting / enabling the laser
 - Defined in 76.3.2.5, mandatory for ONU Tx (burst mode transmission) and present in OLT (but very simplified)
- In 10G-EPON, Synchronizer present in Rx direction
 - RS(255,223) was selected to support both 10G-class PIN and APD receivers. This may not be true anymore in NG-EPON
 - Processing load caused by FEC was optimized in 10G-EPON to support ASIC expected to be available by 2010. ASIC implementations in 2015 are much more powerful and more complex FEC could be used in NG-EPON.
 - RS(255,223) adds constant (stream-based FEC) overhead of ~14%. A lower overhead FEC would be welcome for NG-EPON.

Data Detector / Synchronizer (2)

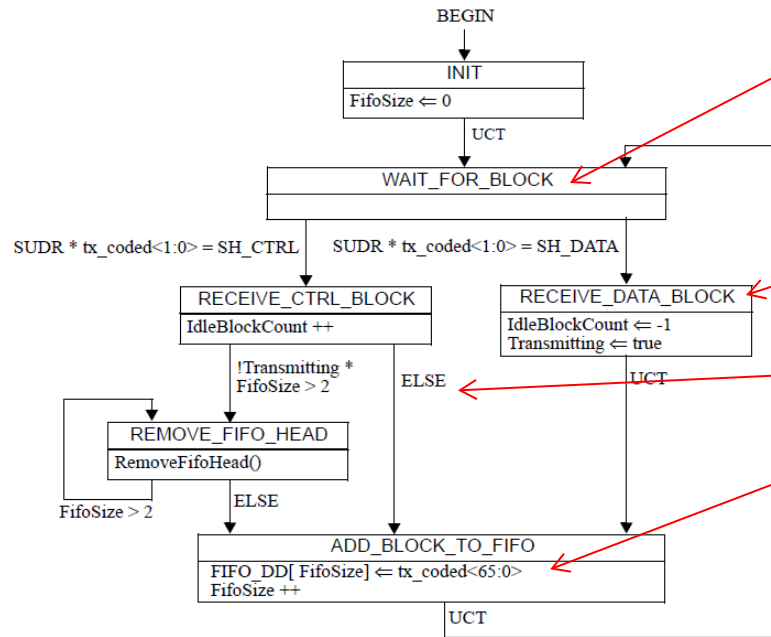
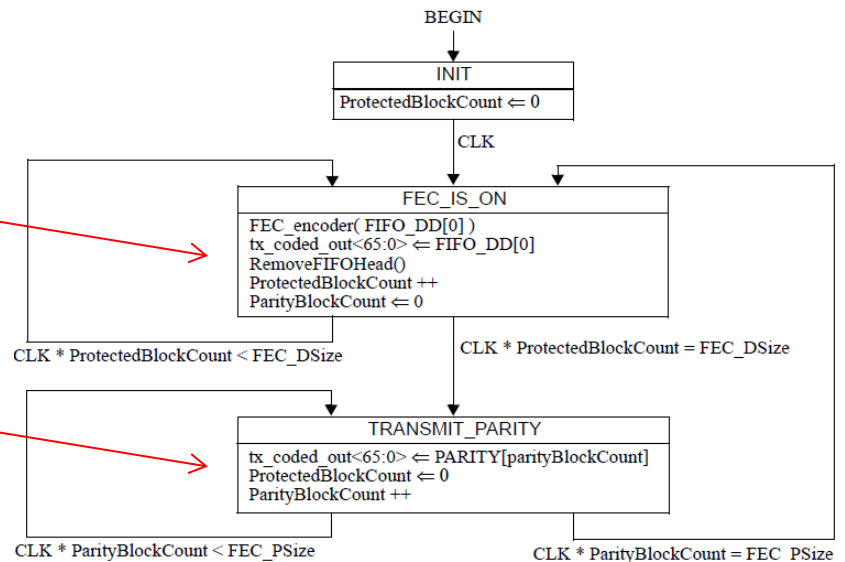

Figure 76-16—Data Detector, input process state diagram

Data from FIFO_DD is sent out until
FEC payload is filled in

Afterwards, FEC parity data is transmitted



(a) OLT state diagram

Data Detector / Synchronizer (3)

Laser is switched on

Burst Preamble is transmitted

Burst Start Delimiter is transmitted

Data from FIFO_DD is sent out until
FEC payload is filled in

Afterwards, FEC parity data is transmitted

Burst Terminator is transmitted

Laser is switched off

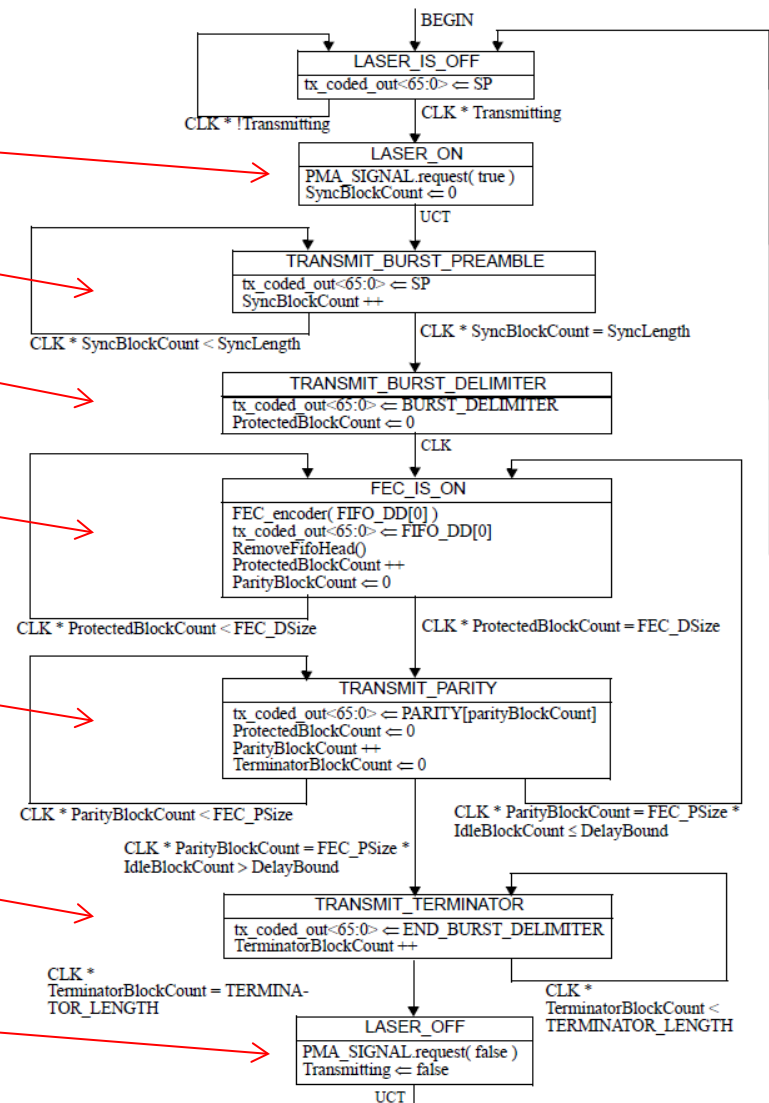

(b) ONU state diagram

Figure 76-17—Data Detector, output process state diagram

Data Detector / Synchronizer (4)

- Proposal for NG-EPON:
 - Adopt per-lane Data Detector and Synchronizer, defined for 10G-EPON, as baseline proposal for NG-EPON
 - Each data lane in NG-EPON is operated independently, i.e., Data Detector and Synchronizer is done independently from other data lanes.
 - Details are described in the following subclauses:
 - Data Detector: 76.3.2.5
 - Synchronizer: 76.3.3.1 (OLT) and 76.3.3.2 (ONU)

Other items for NG-EPON PCS (1)

- Synchronization between individual lanes
 - lane de-skew within PCS to present a single de-skewed service interface to MAC Client or within MPCP+ (compensate transmission times)?
- PCS specification itself:
 - Can we specify 25/25GBASE-PR and 25/10GBASE-PR PCS/RS and then connect these to 25/25G, 25/10G, 50G, and 100G PHYs, or do we need to specify also 50G and 100G PCS/RS?
 - Do we need to specify other PCS combinations, like 50/10G, 50/25G, etc.?
- Broadcast LLIDs:
 - Do we use a single broadcast LLID for all NG-EPON speeds or use one broadcast LLID for each speed, i.e., 25G, 50G, 100G ONUs?
 - Do we also need to add a broadcast LLID to reach all NG-EPON ONUs?

Other items for NG-EPON PCS (2)

- Native support for IEEE Std 802.3bf
 - time stamping at xMII (Clause 90) requires well bounded delay through stack for synchronization messages
 - **See separate contribution hajduczenia 3ca 2 0516**
- Native support for clock / frequency distribution
 - Some additional messaging interleaved within PCS into bit stream to facilitate clock / frequency distribution across PON?
 - Pending contribution on requirements / support
- Ability to disable FEC when operating under very favorable optical link conditions
 - Ideally, per ONU, but on per OLT would be also welcome
 - This allows operators with short optical links to recover bandwidth overhead from FEC parity, when operating on favorable ODN
 - Most likely to be removed, pending power budget analysis

**bright
house**
NETWORKS



THANK YOU!