

Ethernet Adoption: SERDES Rates & Form Factors

Jeffery J. Maki

Supporters

Scott Kipp, Brocade

Matt Traverso, Cisco

Tad Hofmeister, Google

Vijay Vusirikala, Google

Thananya Baldwin, Ixia

Jerry Pepper, Ixia

David Ofelt, Juniper Networks

David Estes, Spirent

Paul Brooks, Viavi Solutions

Earlier Presumed Data Center Form Factor Roadmap

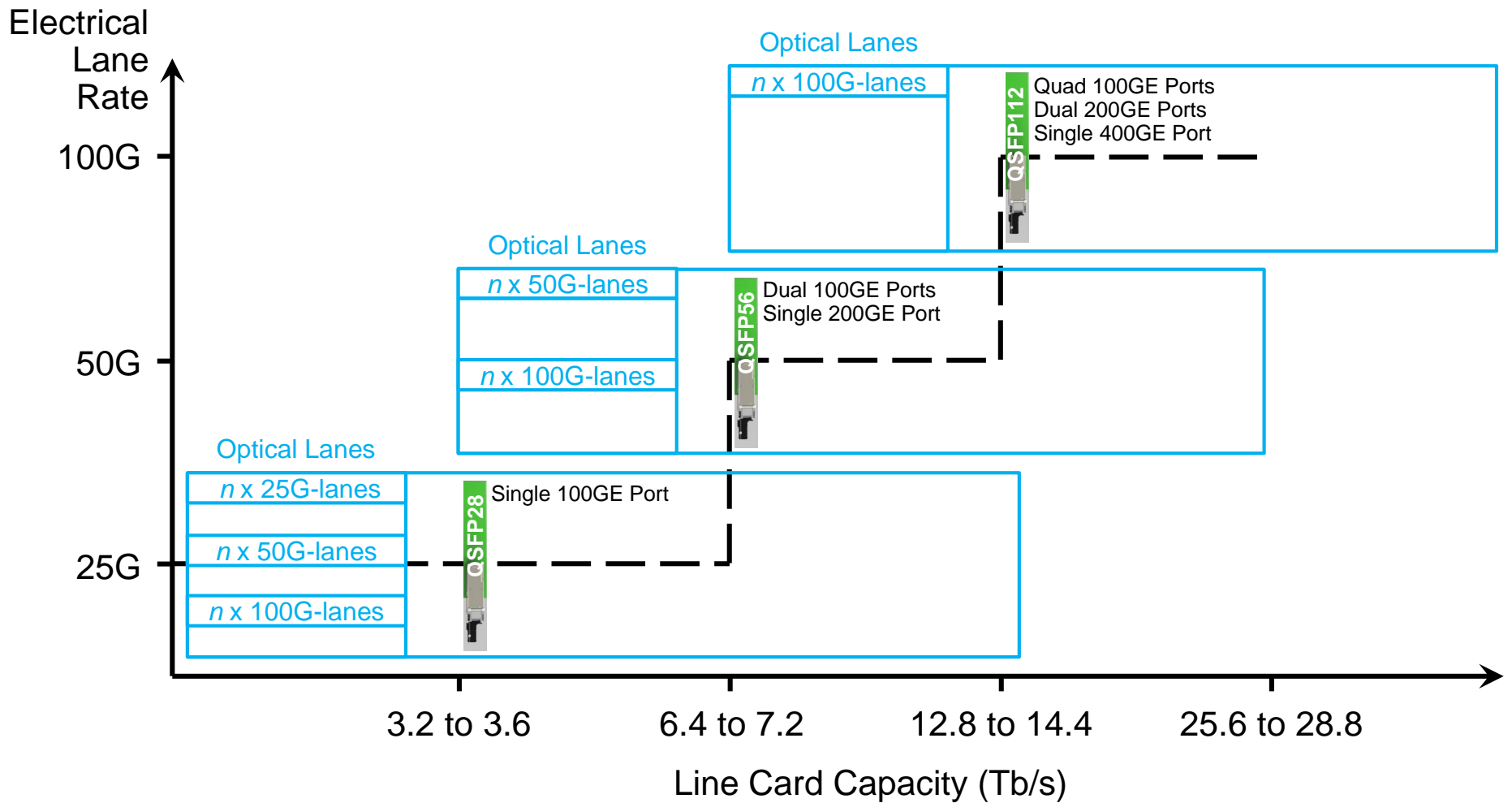

Earlier Assumptions

New SERDES rate needed for each new density increase in QSFP form factor

400GE could not be supported until 100G SERDES developed

Doubling 100GE density (over QSFP28) needed 50G SERDES

QSFP Double Density Form Factor, the QSFP-DD

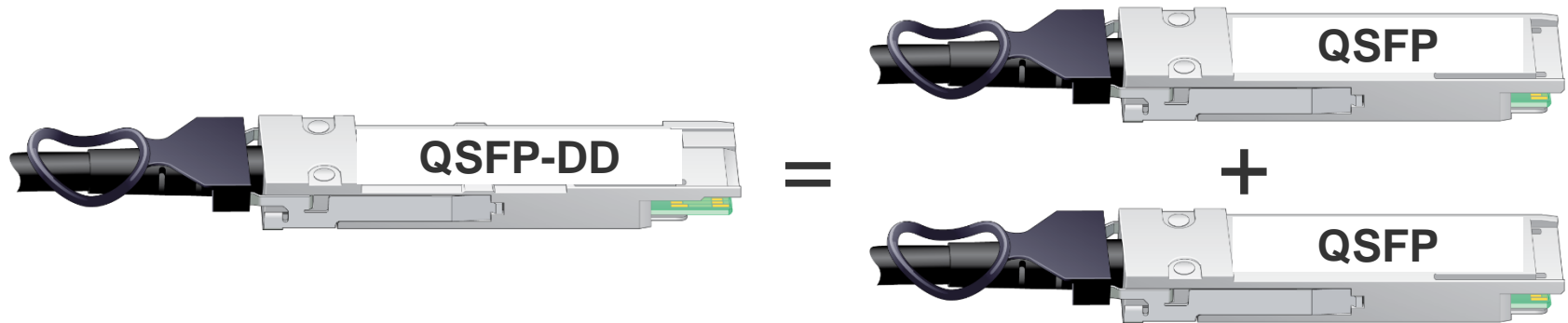

Impact of QSFP-DD

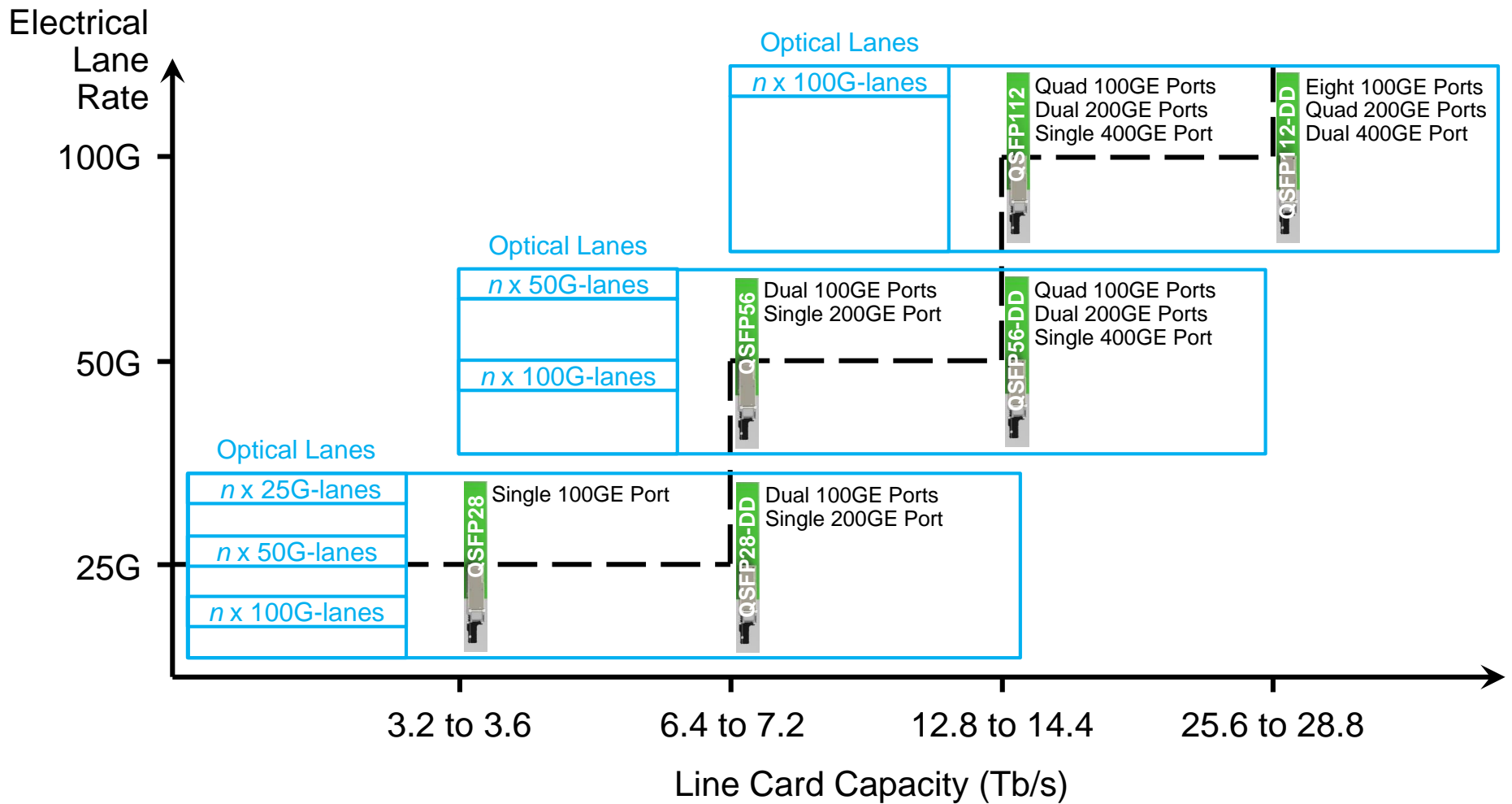

New Opportunity

Existing 100GE can be doubled in density (over QSFP28) using QSFP28-DD and 25G SERDES; no need to wait for 50G SERDES

- Interop can be preserved for one more system generation

NG 100GE can be introduced (in QSFP56) at the same system density as existing 100GE (in QSFP28-DD) giving an orderly transition from old to new

400GE can be introduced using 50G SERDES; no need to wait for 100G SERDES

200GE could be introduced with future systems persisting with 25G SERDES

CFP8 & COBO Included

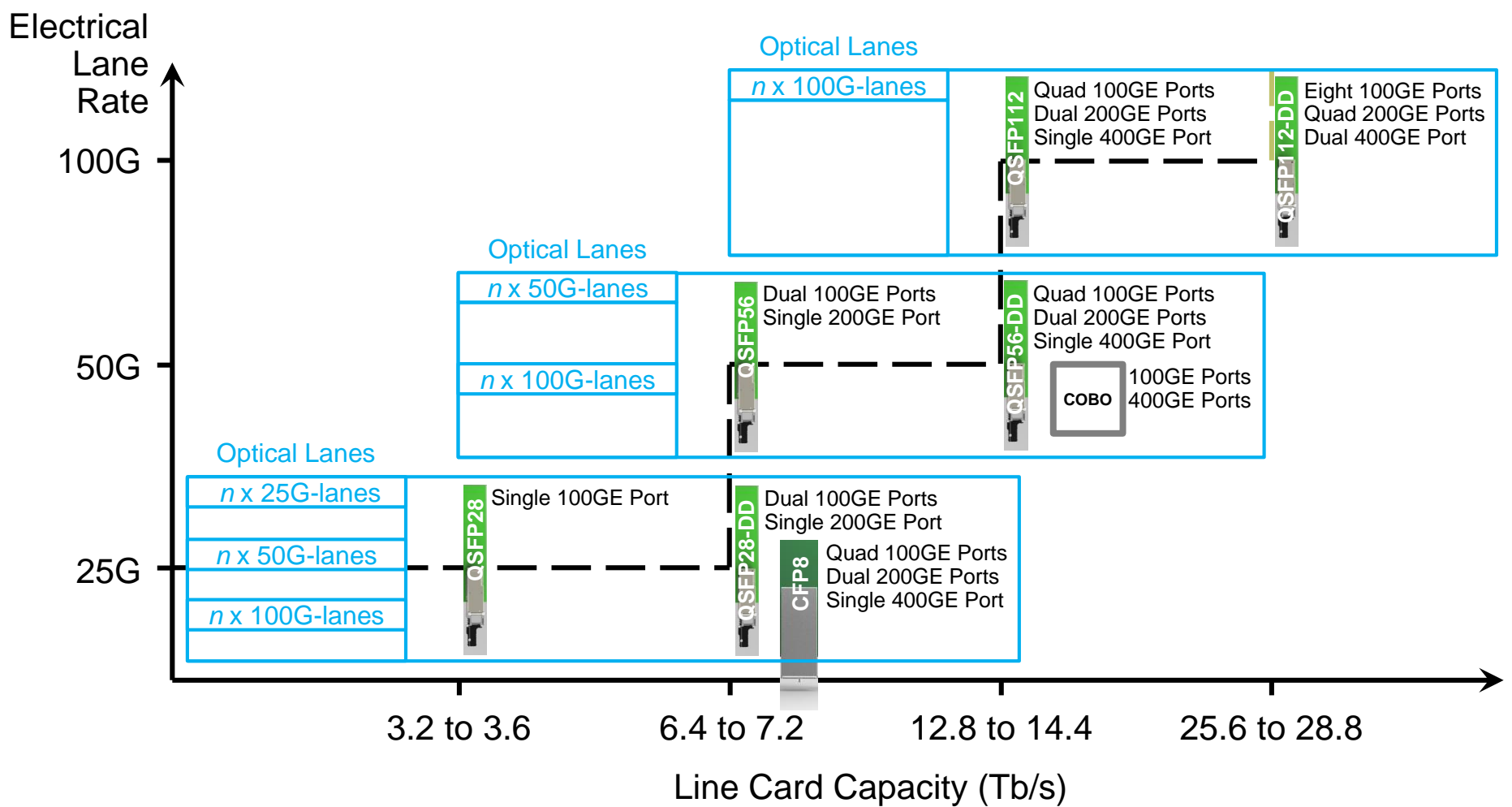

Impact

CFP8 enables 400GE with 25G SERDES; no need to wait for 50G SERDES

- 200GE can also be supported

Common bandwidth density provided by

- QSFP28-DD for 2 ports of existing 100GE and CFP8 for 400GE
- COBO for NG 100GE and 400GE

COBO provides for a variety of line card capacities using 50G SERDES; no need to wait for 100G SERDES

Summary Discussion

Existing 100GE can be preserved up to 7.2 Tb/s line card capacity systems using 25G SERDES

NG 100G for 2-km reach on duplex SMF should be invariant over form factor and system density to preserve interop over system generation

- CWDM2 (2x50G- λ) is lower cost than 100GBASE-LR4 and even 100G-CWDM4. Can we afford to ignore it?
- Is CWDM2 appropriate to expect to be supported in QSFP56-DD as a 4-port module? It would need to be.
- 100G serial (100G- λ) will be supportable in QSFP56-DD as a 4-port module since 400GBASE-DR4 shall be supported.

Interop within a SERDES generation is extremely important

- 100GBASE-LR4 was actually supported over two SERDES generations, namely, 10G and 25G.
- Can the industry wait for 100G serial to be the new interoperable 100G optical signal when using 50G SERDES? How long is the wait?

Recommendations

Delay need for NG 100GE on duplex SMF for 2-km reach by using QSFP28-DD to double the bandwidth density over QSFP28 using existing 100GE with KR4 FEC

Use delay to give industry time to develop NG 100GE using 100G serial (100G- λ); guide towards this being the next and final specification for 100GE interoperability

Gather contributions on whether this delay is sufficient to meet the time horizon for adoption of NG 100GE in QSFP56-DD (quad ports) or similar bandwidth-density form factor such as OSFP

Assess whether market exists for bookended applications where legacy interoperation is not needed and cost reduction is attractive to trigger need for CWDM2 as a short “shelf-life” standard