

# 50 Gb/s per lane MMF baseline proposals

P802.3cd, Whistler, BC

21<sup>st</sup> May 2016

Jonathan King, Finisar

Jonathan Ingham, FIT

# Supporters

- Chris Cole, Finisar
- Doug Coleman, Corning
- Scott Kipp, Brocade
- Kent Lusted, Intel
- Jeff Maki, Juniper
- Rick Pimpinella, Panduit
- Rick Rabinovich, Ixia
- Qing Xu, Belden

# Contents

- Adopted MMF objectives
- Baseline proposals for retimed single-lane 50Gb/s and four-lane 200Gb/s PAM4 PMDs
  - Physical layer specifications which support link distances of at least 100 m on MMF
    - FEC supported (RS-544) or similar to enable 100 m reach
  - Single-lane, and four-lane short wavelength based PMDs for 50GBASE-SR and 200GBASE-SR4
  - Leveraging an evolution of 25G NRZ optics, CDAUI-8 50 Gb/s electrical interfaces, and some of the PAM4 metrics developed in 802.3bs
- Architecture, parameters and specifications for optical interfaces follow.

# Adopted MMF Objectives

- **Define a single-lane 50 Gb/s PHY for operation over MMF with lengths up to at least 100 m.**
- Define a two-lane 100 Gb/s PHY for operation over MMF with lengths up to at least 100 m.
- **Define a 200 Gb/s PHY for operation over MMF with lengths up to at least 100 m.**

# Motivation

- Single-lane and four-lane links using PAM4 modulation at 26.5625 GBd/lane
- Utilize low cost, high performance MMF compatible optics and electronics
  - Leverage 28 Gb/s NRZ optics technology used in 25G, 100G, 400G Ethernet, and 32G Fibre Channel
  - FEC-supported retimed interface enables a lowest power, lowest cost, 100 m solution today
  - Uses existing viable semiconductor technologies and uncooled VCSELs
- Single optical lane directly maps to a single electrical lane of 50GAUI or CCAUI, without requiring multiplexing, translation, or de-skewing inside the module.
- This proposal is supported by multiple vendors and users, and is economically feasible and competitive compared to other alternatives.

# Proposal

- Single optical lane per direction for 50GBASE-SR
- Four optical lanes per direction for 200GBASE-SR4
- Each lane @ 26.5625 GBd PAM4 over 100 m OM4 fiber.
  - Exact signaling rate is determined by project's choice of FEC.
- 850 nm sources and receivers
  - Assumes target BER (prior to error correction) around  $2.4 \times 10^{-4}$  and random error statistics

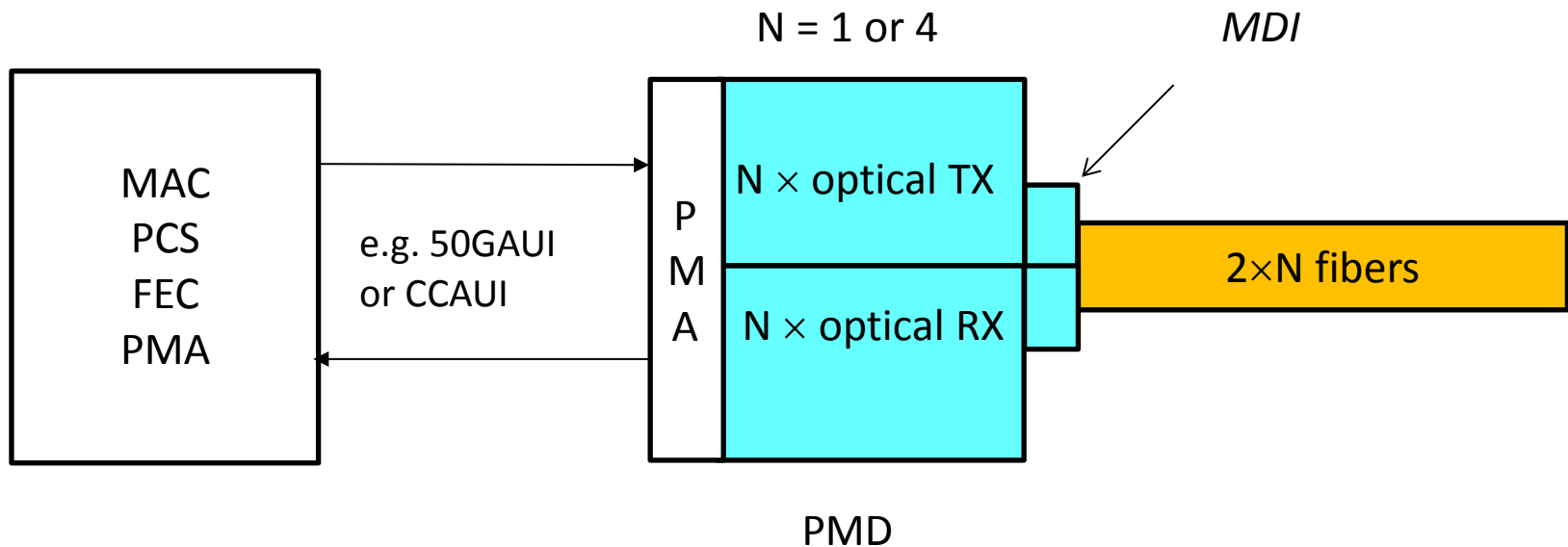

# 50GBASE-SR: Position in 802.3 architecture

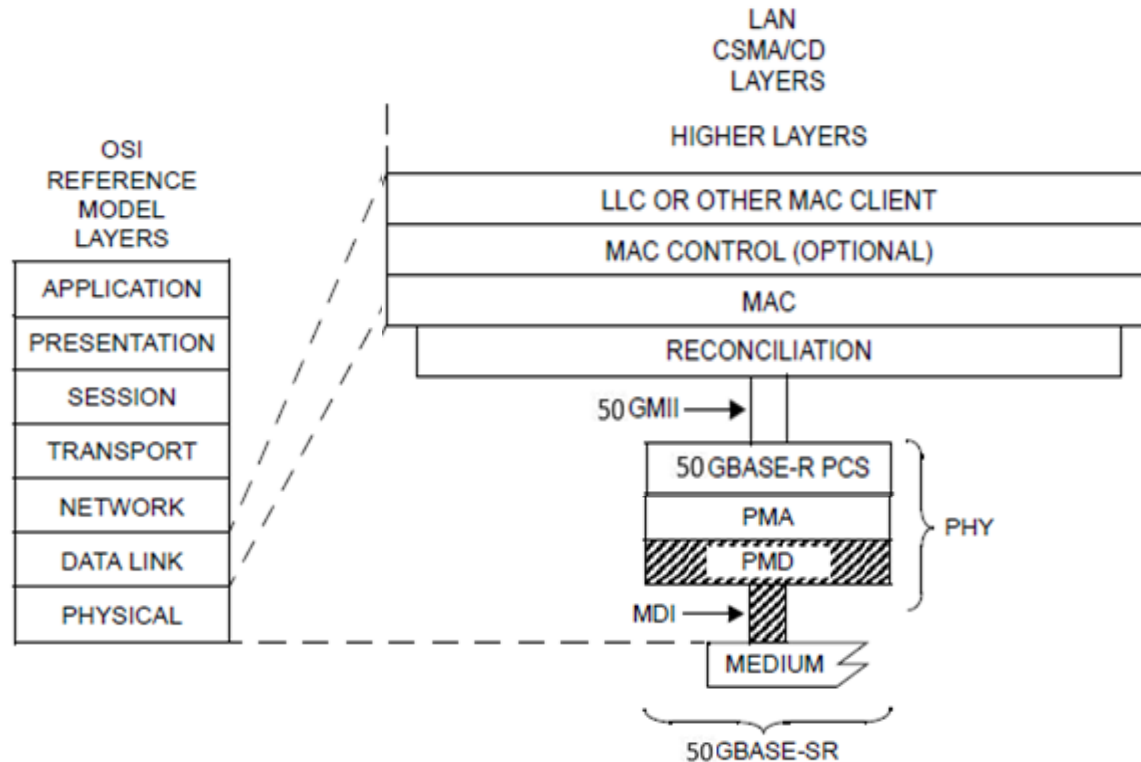

50 GMII = 50 Gb/s MEDIA INDEPENDENT INTERFACE  
 LLC = LOGICAL LINK CONTROL  
 MAC = MEDIA ACCESS CONTROL  
 MDI = MEDIUM DEPENDENT INTERFACE  
 PCS = PHYSICAL CODING SUBLAYER

PHY = PHYSICAL LAYER DEVICE  
 PMA = PHYSICAL MEDIUM ATTACHMENT  
 PMD = PHYSICAL MEDIUM DEPENDENT  
 SR = PMD FOR MULTIMODE FIBER

# 200GBASE-SR4: Position in 802.3 architecture

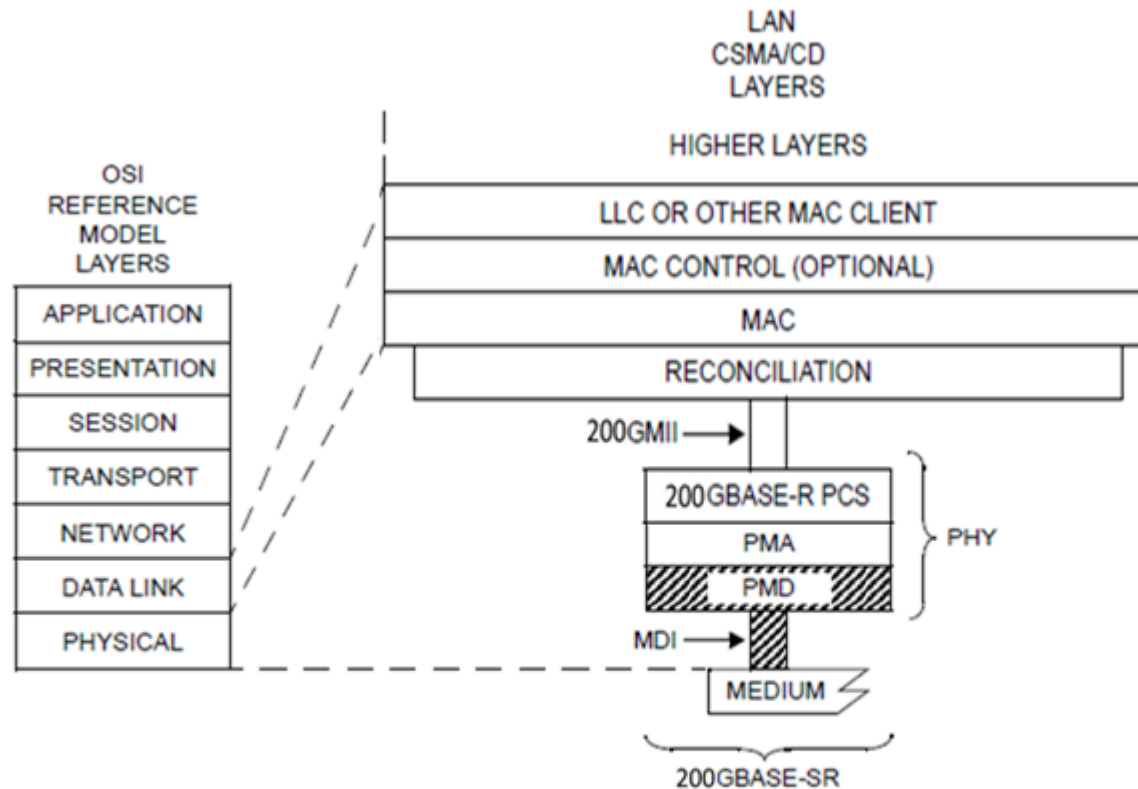

200GMII = 200Gb/s MEDIA INDEPENDENT INTERFACE  
 LLC = LOGICAL LINK CONTROL  
 MAC = MEDIA ACCESS CONTROL  
 MDI = MEDIUM DEPENDENT INTERFACE  
 PCS = PHYSICAL CODING SUBLAYER

PHY = PHYSICAL LAYER DEVICE  
 PMA = PHYSICAL MEDIUM ATTACHMENT  
 PMD = PHYSICAL MEDIUM DEPENDENT  
 SR = PMD FOR MULTIMODE FIBER



# Transmitter characteristics (each lane) at TP2

Description	Value	Unit
Signaling rate, each lane, (range)	26.5625 ± 100ppm	GBd
Modulation format	PAM4	
Center wavelength (range)	840 - 860	nm
RMS spectral width	0.6	nm
Average launch power, each lane (max)	+4	dBm
Average launch power, each lane (min)	-6	dBm
Optical Modulation Amplitude (OMA <sub>outer</sub> ), each lane (max) <sup>a</sup>	+3	dBm
Optical Modulation Amplitude (OMA <sub>outer</sub> ), each lane (min) <sup>ab</sup>	-4 <i>TBC</i>	dBm
Launch power in OMA <sub>outer</sub> minus TDECQ (min) <sup>a</sup>	-5 <i>TBC</i>	dBm
Transmitter and dispersion eye closure (TDECQ), each lane (max) <sup>a</sup>	4 <i>TBC</i>	dB
Average launch power of OFF transmitter, each lane (max)	-30	dBm
Extinction ratio (min) <sup>a</sup>	3	dB
Encircled Flux	≥ 86% at 19 μm ≤ 30% at 4.5 μm	

<sup>a</sup> OMA<sub>outer</sub>, and TDECQ are as defined in 802.3bs; the 5 tap T/2 reference is *TBC* for MMF links

<sup>b</sup> Even if TDECQ is <1dB, OMA<sub>outer</sub> must be at least this value

# Receiver characteristics (each lane) at TP3

Description	Value	Unit
Signaling rate, each lane, (range)	26.5625 ± 100ppm	GBd
Modulation format	PAM4	
Center wavelength (range)	840 - 860	nm
Damage threshold (min)	+5	dBm
Average receive power, each lane (max)	+4	dBm
Average receive power, each lane (min)	-7.9	dBm
Receive power, each lane (OMA <sub>outer</sub> ) (max)	+3	dBm
Receiver reflectance (max)	-12	dB
Stressed receiver sensitivity (OMA <sub>outer</sub> ), each lane (max) <sup>a</sup>	-3 <i>TBC</i>	dBm at 2.4 x 10 <sup>-4</sup>
Receiver sensitivity (OMA <sub>outer</sub> ), each lane (max) <sup>ab</sup>	-7 <i>TBC</i>	dBm at 2.4 x 10 <sup>-4</sup>
Conditions of stressed receiver sensitivity test		
Stressed eye closure (SECQ), lane under test <sup>a</sup>	4 <i>TBC</i>	dB
OMA of each aggressor lane	+3	dBm

<sup>a</sup> OMA<sub>outer</sub>, and SECQ are as defined in 802.3bs, the 5 tap T/2 reference is *TBC* for MMF links

<sup>b</sup> Receiver sensitivity is informative

# Illustrative link power budget (each lane)

Parameter	OM3	OM4	Unit
Effective modal bandwidth at 850 nm	2000	4400	MHz.km
Power budget (for max TDECQ)	6.0 <i>TBC</i>		dB
Operating distance	70	100	m
Channel insertion loss	1.8	1.9	dB
Allocation for penalties (for max TDECQ)	4.1 <i>TBC</i>		dB
Additional insertion loss allowed	0.1	0	dB

# Concluding remarks

- Baseline proposals for single-lane 50G and four-lane 200G PMDs, based on 50 Gb/s PAM4 per lane, offer:
  - an evolution of current 25 G VCSEL and receiver optics, to manage RIN and increase link budget
  - substantial re-use of transmitter and receiver electronics technologies, developed for 50Gb/s PAM4 over SMF
  - substantial re-use of the Tx and Rx quality metrics for SMF, under development in P802.3bs
  - substantial amount of work from several groups showing technical feasibility
- 100 m on OM4 is achievable with RS-544 support or similar
- Potentially compatible with SFP28 form factors
  - four lane variant compatible with QSFP28 form factors

Q & A

Thanks !