

Ethernet WDM Aggregation Networks

Call For Interest

Duane Remein
Yiran Ma
Chris Cole

Huawei Technologies Co. Ltd
China Telecom (visa issues)
Finisar Corporation

Supporters

Klaus Grobe
Brian Teipen
Bill Powell
Dan Dove
Xian-Li Yeh
Jason Dove
Hal Roberts
Yiran Ma
Wang Bo
Dr Xin Chen
Dr Richard Wyatt
Hugh Barrass
Mark Nowell
Chris Cole
Mike Fukatsu
Jonathan King
Wen Li
Henk Bulthuis
Liuyong Chen
Changfei Hu
Susumu Himi
Hesham ElBakoury
Duane Remein
Peter Stassar
Zhiguang Xu

ADVA Optical Networking
ADVA Optical Networking
Alcatel-Lucent
Applied Micro
Archcom
Calix
Calix
China Telecom
China Telecom
CIP Technologies
CIP Technologies
Cisco Systems, Inc
Cisco Systems, Inc
Finisar Corporation
Finisar Corporation
Finisar Corporation
Finisar Corporation
Gemfire europe ltd.
HG Genuine Optics Co.,Ltd
HG Genuine Optics Co.,Ltd
Hitachi Cable,Ltd.
Huawei Technologies Co. Ltd
Huawei Technologies Co. Ltd
Huawei Technologies Co. Ltd
Huawei Technologies Co. Ltd

Radha Nagarajan
Ted Sprague
Lisa Tongning Li
David Li
Tsahi Daniel
Dimitry Melts
David Piehler
Domenico di Mola
Rang Chen Yu
Kun Liu
Randy Perrie
Jon Anderson
Valy Ossman
Ao Li
Liu Qian
Katsuhisa Tawa
Pavel Zivny
Denis Beaudoin
Valerie Maguire
Dr. Lian K Chen
Frank Chang
Gareth Edwards
Mark Gustlin
Nick Weiner

Infinera
Infinera
Inphenix. Inc.
Hisense-Ligent
Marvell
Marvell
NeoPhotonics
Oplink
Oplink
Oplink
OneChip Photonics
Opnext
PMC-Sierra
RITT
RITT
Sumitomo Electric Industries, LTD
Tektronix, Inc.
Texas Instruments
The Siemon Company
Chinese University of Hong Kong
Vitesse Semiconductor
Xilinx
Xilinx
Xintronix

49 Individuals
31 Entities

Agenda

- Introduction
 - Objectives
 - Problem Statement
- Market & Potential/Applications
 - NA / ASIA / EU / Other
 - Mobile backhaul
 - Business Services
 - CO Consolidation
 - HFC Upgrade
- Technical Examples
 - Candidate technologies
 - Examples
- Why Now?
- Q&A
- Straw Polls

Objectives of this meeting

- To assess the interest in starting a study group to develop a standards project proposal (PAR and 5 Criteria) for Ethernet WDM Aggregation Networks
- We don't need to:
 - Fully explore the problem
 - Debate the strengths and weaknesses of any given solution
 - Select a solution
 - Create the PAR or the 5 critters
 - Create a standard
- Ground Rules
 - Anyone may speak
 - Be respectful and be respected

What is the Problem?

- Very high, sustained bandwidth clients are not served well with existing shared medium technologies. ⁽¹⁾
 - Mobile backhaul
 - High bandwidth customers
 - An appropriate P2P shared media solution is needed
- Certain clients require a higher level of security (i.e., physical layer) than is available on existing shared medium technologies.
 - Requires a pure peer to peer, P2P network.
- Certain clients prefer the robustness of P2P networks over P2MP networks that risk service degradation due to “rogue” ONUs.
- Projections indicate sustained growth of business traffic and very high (18x) growth for Mobile Backhaul traffic in the next 4-5 years.

What isn't needed

- **We don't need to replace EPON**
 - EPON is the leading Residential Fiber Access solution
 - EPON is one of 802.3 most successful interfaces
 - 1G-EPON and 10G-EPON appear to be the optimal solution for residential services for the foreseeable future
 - 1G-EPON and 10G-EPON will continue to serve the residential market for many years to come

What is needed?

- Need a solution that provides the fiber efficiencies of EPON with the dedicated bandwidth and security benefits of P2P
 - A method to aggregate services for a high number of high bandwidth P2P end points over a single fiber (30-40 bi-directional links) to alleviate the excessive cost of installing additional fibers
 - Optimized for 1 Gbps or better “Fat Pipe” per end point with
 - very low delay/delay variation
 - dynamic QoS under customer control
 - Wavelength routed architecture to ensure PHY level security (no PHY sees data other than it's own)
 - Targeted towards the access aggregation and business access markets
 - Low cost appropriate for the access market



Ethernet WDM Aggregation Network Markets and Applications

Call For Interest

Potential Markets

- WDM for Mobile Market⁽²⁾: the CloudRAN allows re-architecting RAN (Radio Access network) to centralize baseband processing in locations distant from the radio frequency transceivers. CloudRAN is expected to be 20 to 30% cheaper than traditional RAN (similar value for power consumption)
 - 2015 prediction for global spending on Cloud RAN vs. standard RAN
 - ASIA : 25%
 - North America : 10%
 - Europe : 15%
 - The Upshot: The requirement for extensive dark fiber runs to remote radio heads (RRHs) limits cloud RAN to a small number of very large cities.
 - Eth-WDM is an opportunity to solve the need for extensive dark fiber infrastructure

Potential Market/Applications

- Mobile backhaul
 - Fiber fed cell sites are projected to increase from 142k to 1.9M by 2015 ⁽³⁾
 - In ~2014 small cell site roll out is expected to begin, large volumes expected ⁽³⁾
 - By 2016 iGR expects unmet demand for mobile data will increase nearly 16 fold ⁽⁴⁾
- Fiber based Ethernet Business services are expected to show a 10% annual growth rate ⁽³⁾
 - North American business fiber connection to exceed 2M by 2015 ⁽⁵⁾
 - Significant investments in EU & ASIA
- Aggregation technology would reduce the need to deploy additional fiber accelerating fiber access.

Mobile Backhaul

- LTE or similar protocols requires 1+ Gbps to each antenna
 - P2P requires too many fibers

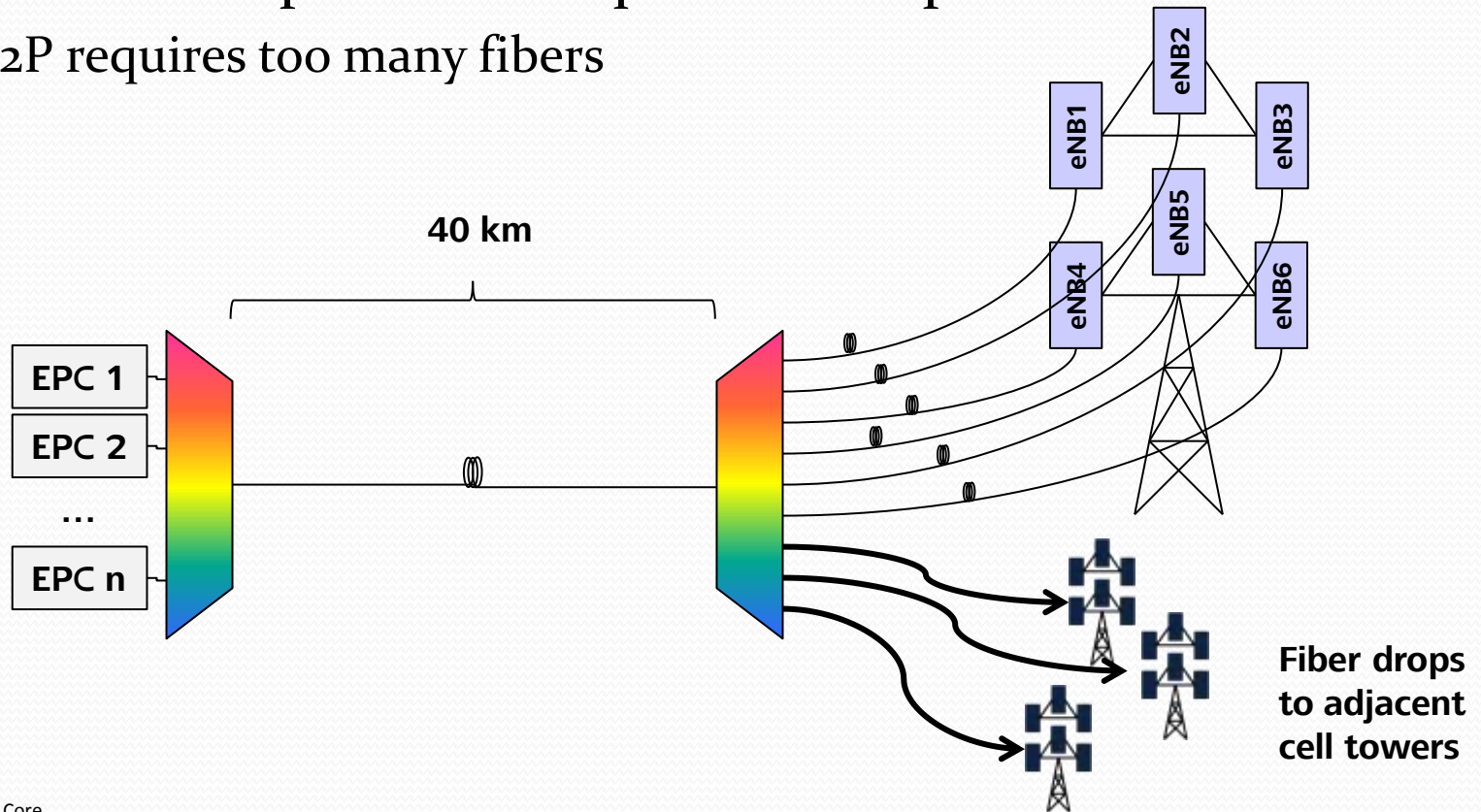

EPC - Evolved Packet Core
eNB - Evolved NodeB

Business services applications

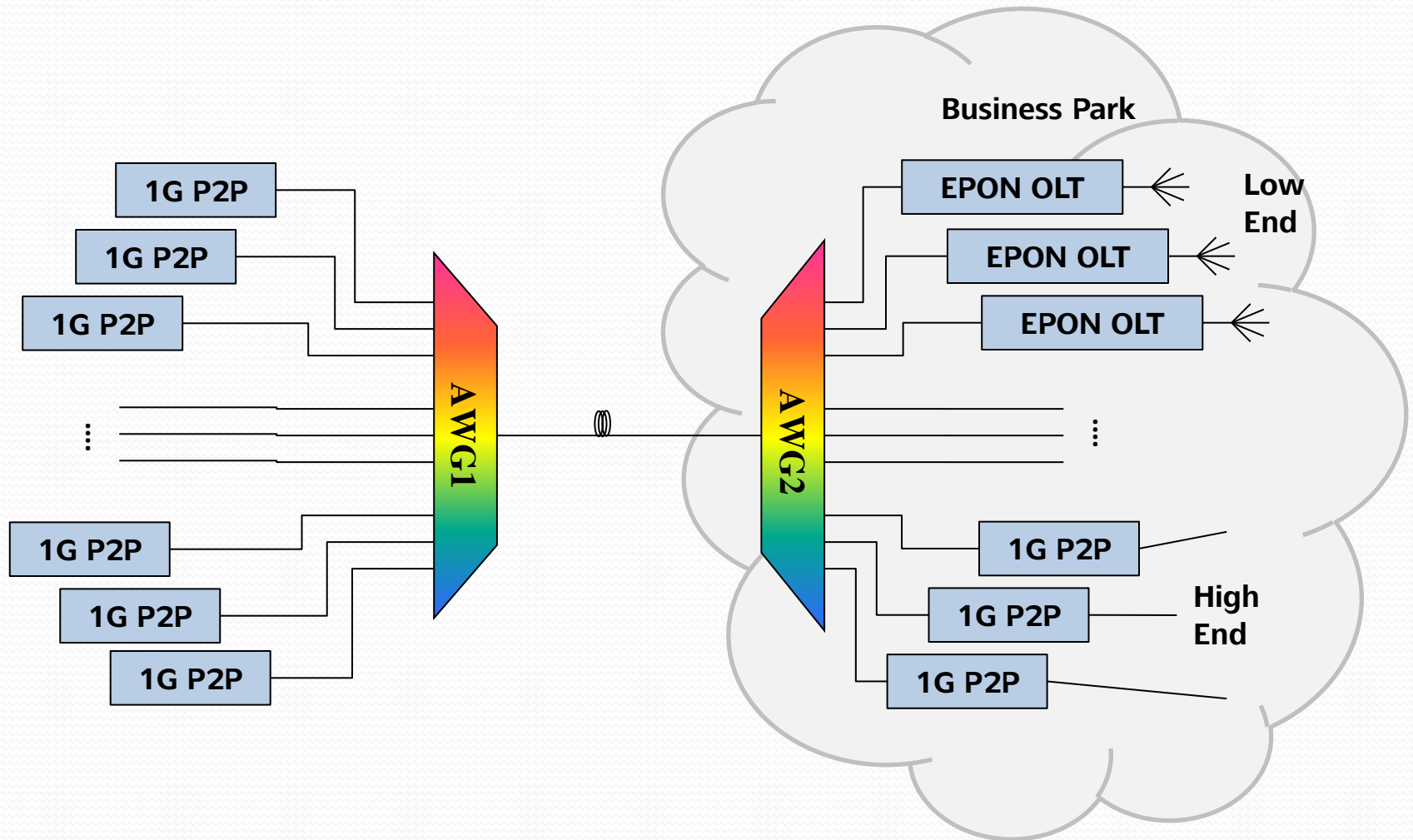

HFC Network Upgrade

- HFC Networks are often served by only a few fibers
- Typical Fiber Node serves between 500 and 1000 subscribers
 - EPON cannot easily service this large a group
 - Need a method to deliver multiple (20-30) EPONs (or EPoC's)

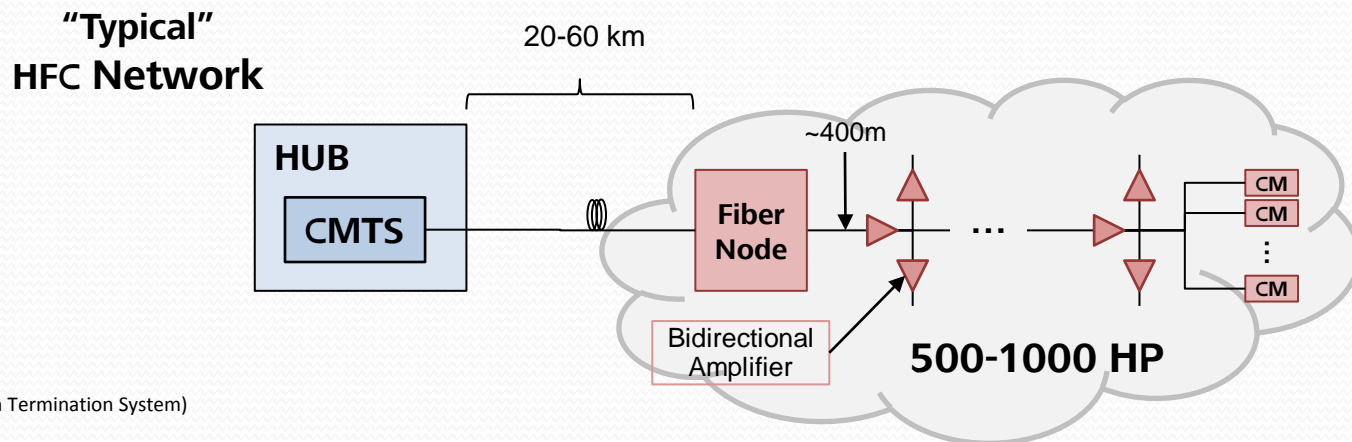

CMTS – (Cable Modem Termination System)
CM – (Cable Modem)

HFC Network Upgrade

- Cable carriers want to upgrade HFC network, but they are facing fiber shortages in the trunk

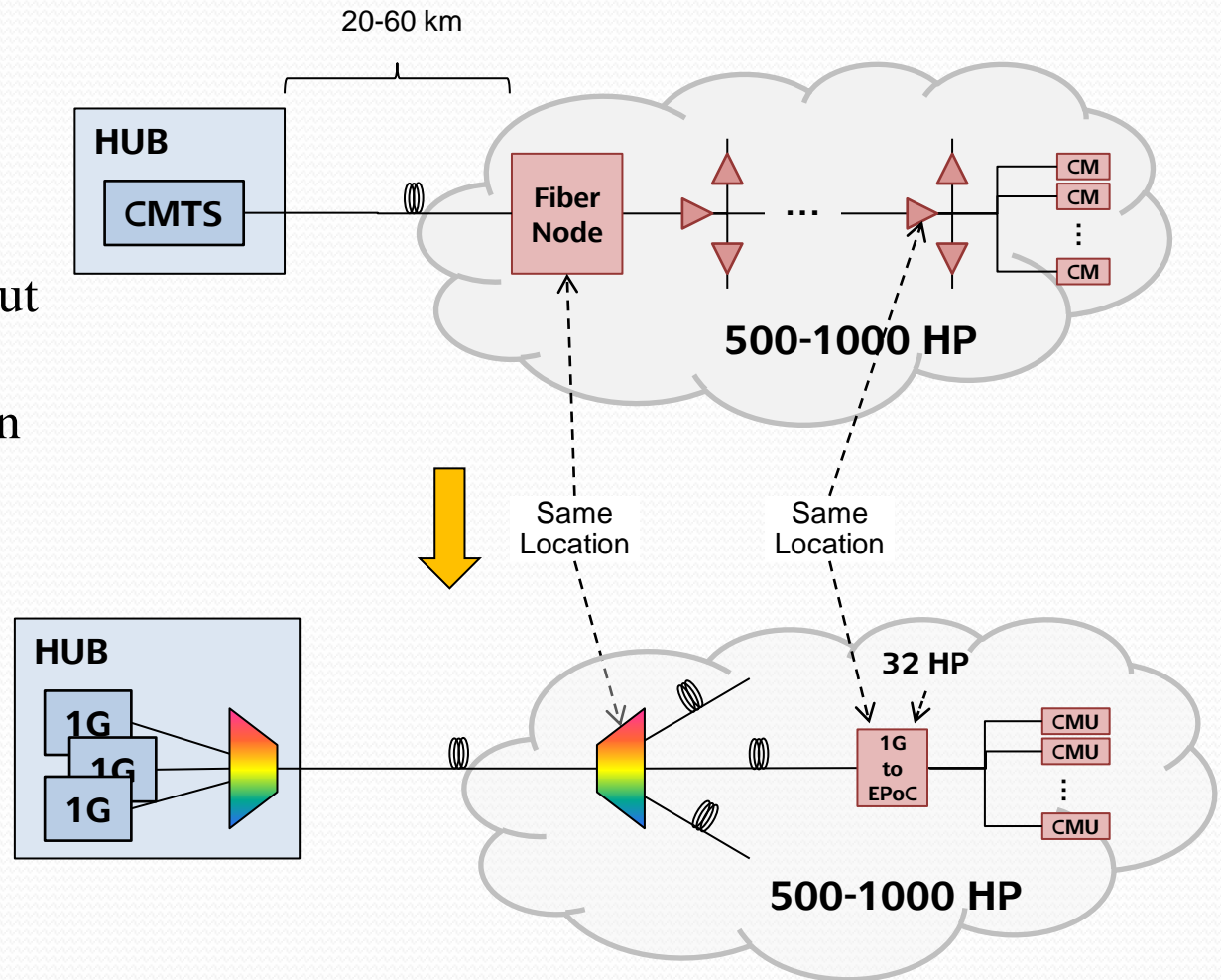

EPoC – (EPON over COAX)
CMU – (Coax Network Unit)

CO Consolidation

- EPON OLTs could be consolidated in a “Super Office”
 - Remote office equipment becomes extremely simple
 - Combined reach of > 80 km may be possible when combined with Ext EPON Optics

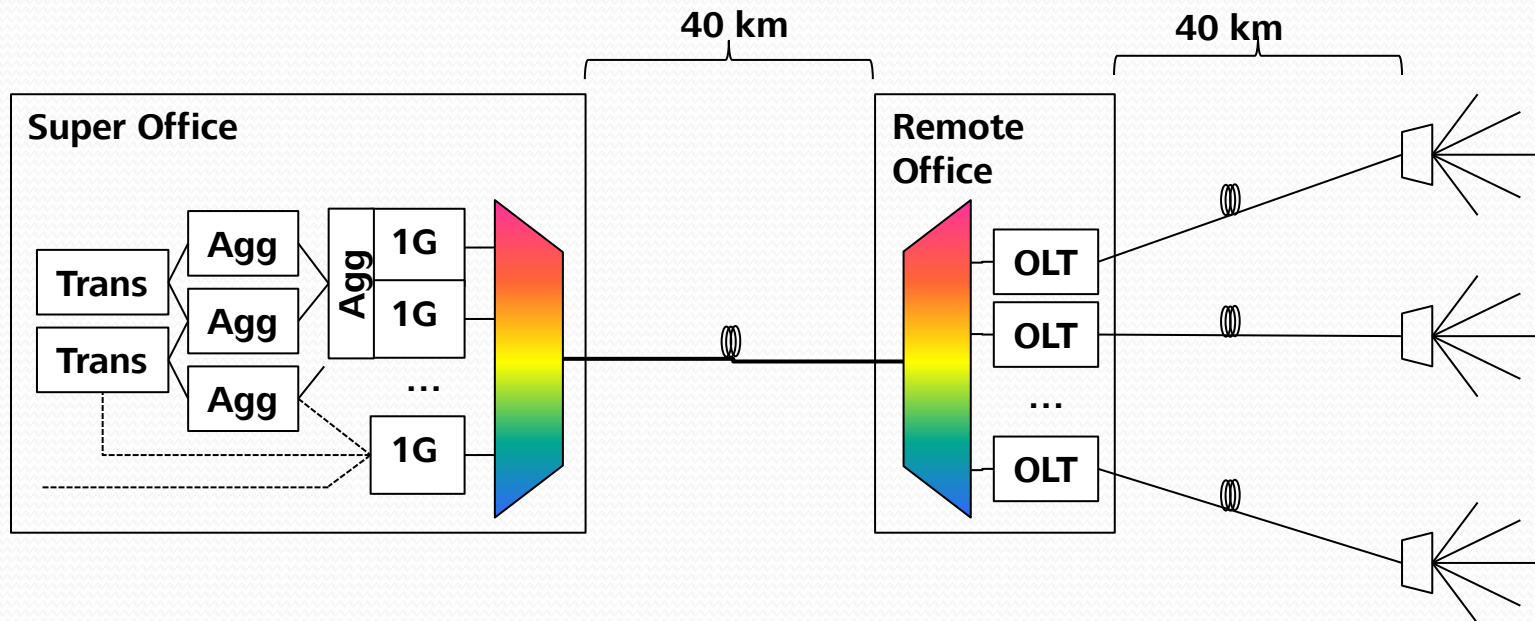



Ethernet WDM Aggregation Network Technical Examples

Call For Interest

Candidate Technologies exist

- Fixed wavelength (CWDM / DWDM)
- Tunable lasers
- Seeded WDM from CO
- Self seeded WDM
- Modulation erasure / wavelength reuse
- OFDM
- ...

CWDM – Course WDM

DWDM – Dense WDM

OFDM – Orthogonal Frequency Division Multiplexing

Tunable lasers

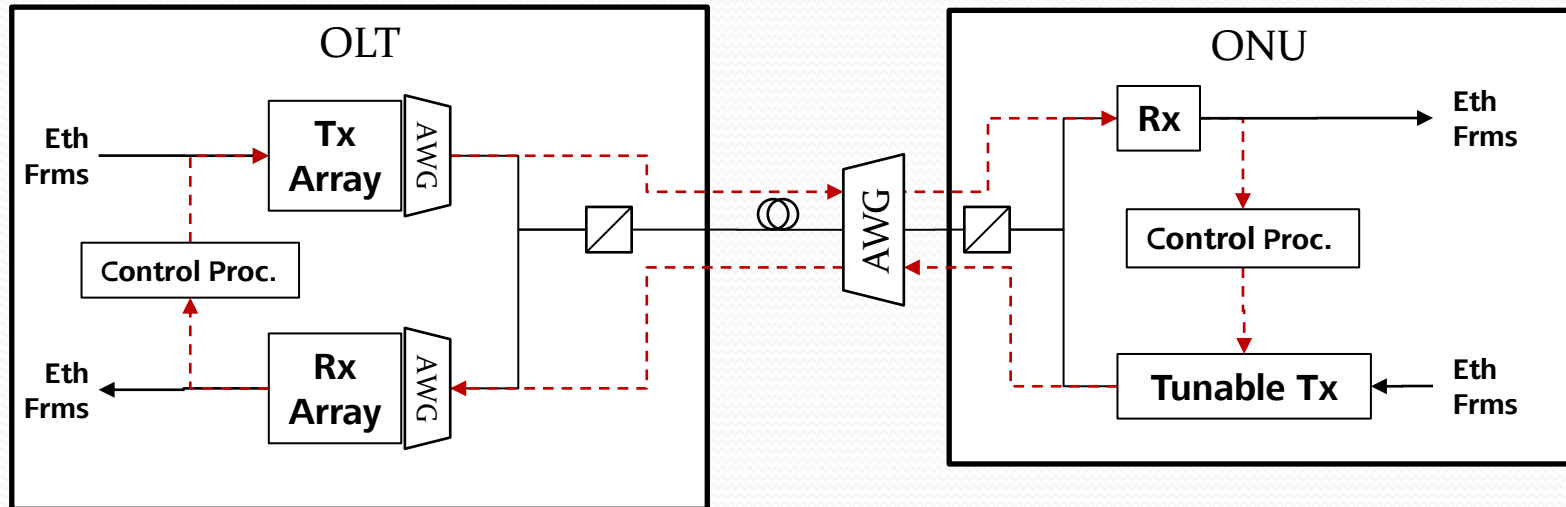

- Could use fixed wavelength laser and photo diode arrays in OLT
- Tunable laser with control function in ONU
- Wavelength tuning mechanism and protocol required to complete control loop
- Transmitters and Receivers could be co-packed into arrays for denser equipment

Self seeded WDM

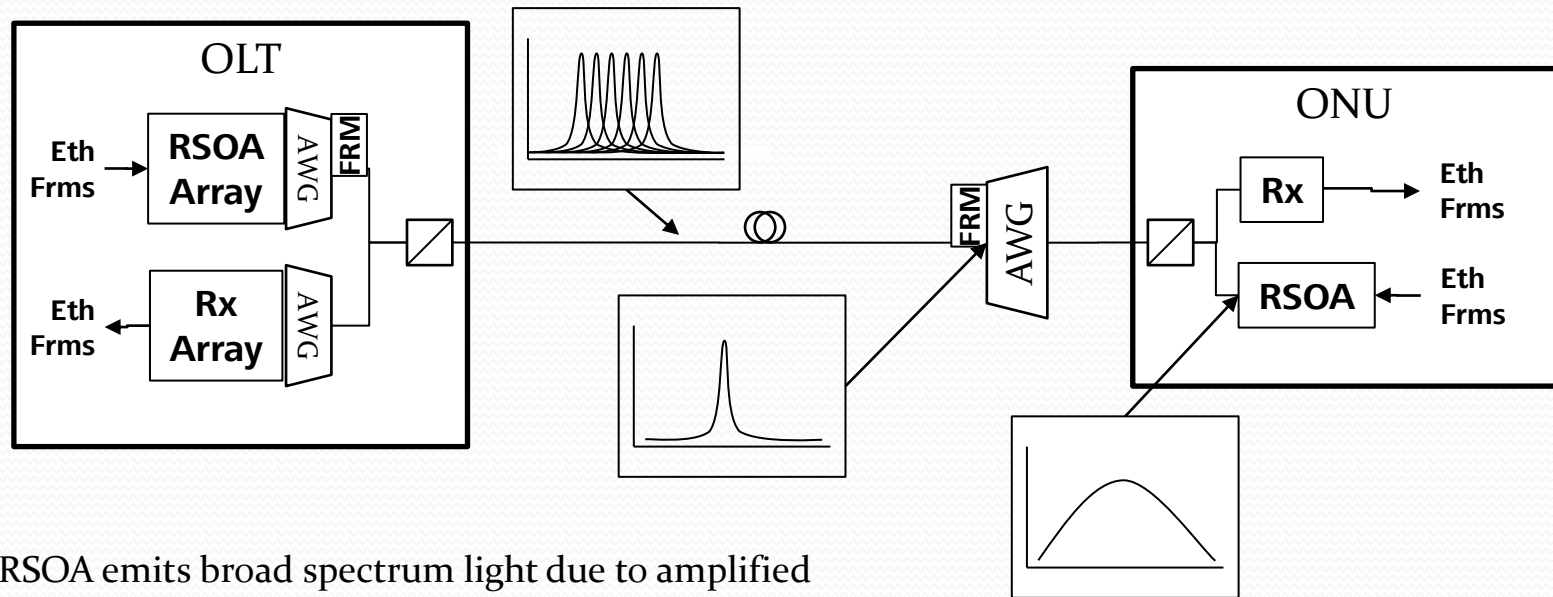

- RSOA emits broad spectrum light due to amplified spontaneous emission (ASE)
- ASE is filtered by AWG
- Filtered ASE is reflected by Faraday Rotating Mirror (FRM)
- RSOA amplifies and modulates the reflected light creating a stable lasing cavity between the RSOA and the FRM
- Both OLT and ONU can have an identical structure

Seeded WDM from CO

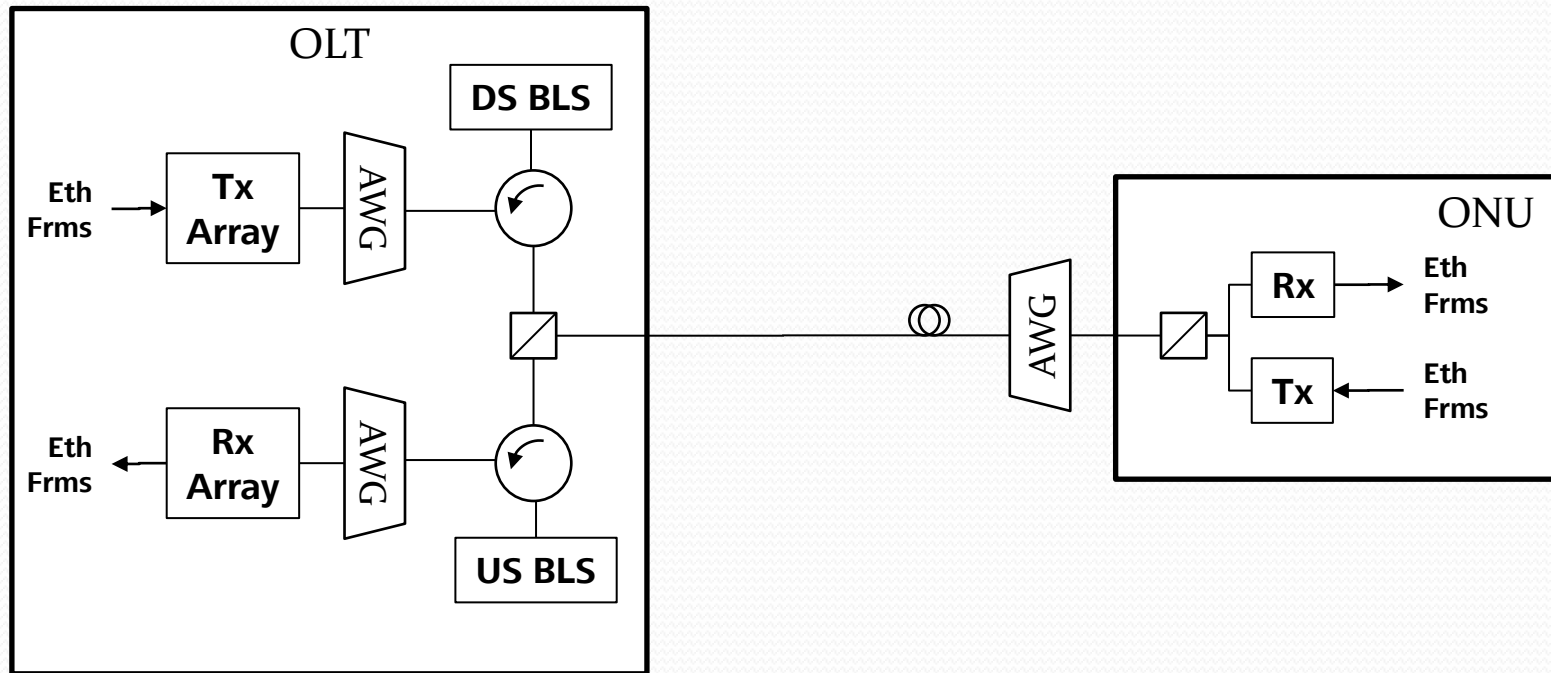

- Laser and photo diode arrays in OLT (could use fixed wavelength laser array)
- Two Broadband Light Sources (BLS) provided seed light to Fabry-Perot laser or RSOA
- AWG filters the BLS into slices
- Fabry-Perot/RSOA laser locks to incoming filtered slice from broadband light source



Ethernet WDM Aggregation Network Why Now?

Call For Interest

A Brief History of Data Access Speeds

Internet Access speeds are, by and large, following Nielsen's Law
{ network connection speeds for high-end home users increase 50% per year ⁽⁸⁾ }

The unrelenting demand for increased bandwidth continues

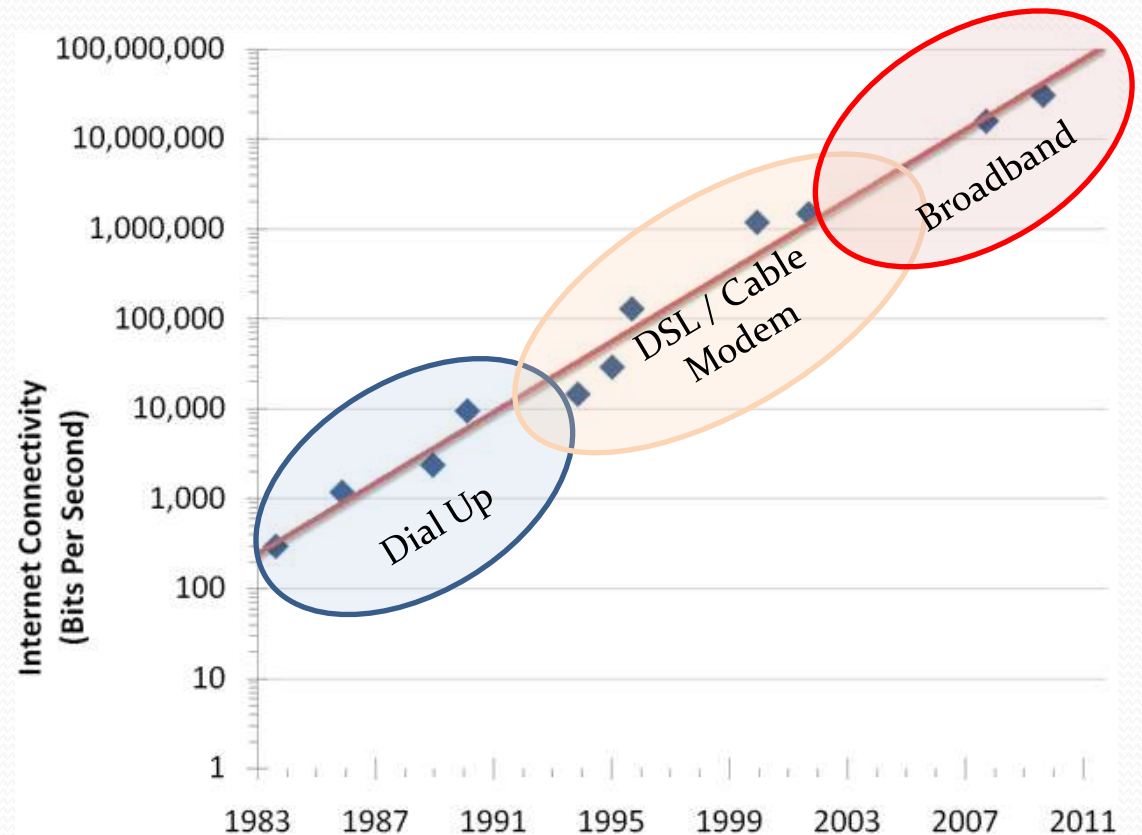

Why a New CFI? (1)

- Business IP traffic increases by 2x by 2015 to 9.4 EB
- Consumer Mobile increases by 12.4x by 2015 to 4.9EB
 - this factor was revised to 18x between 2011 & 2016 ⁽¹¹⁾
- Businesses will need high BW Access solutions.

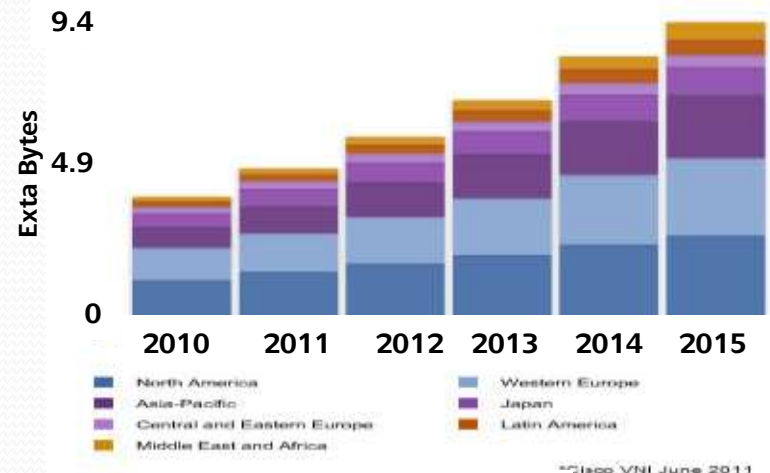
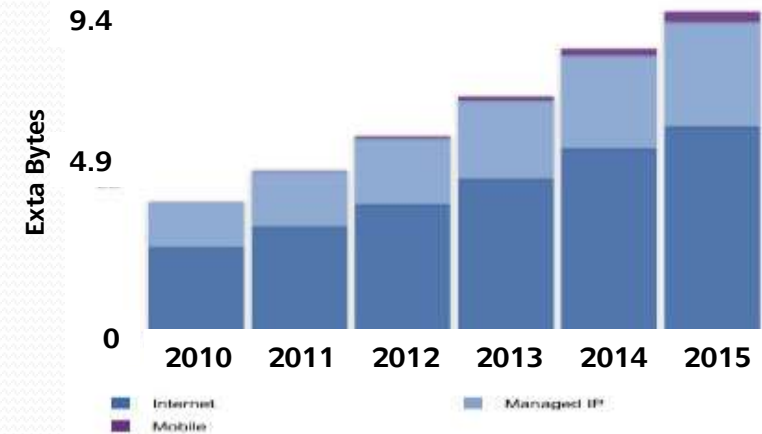
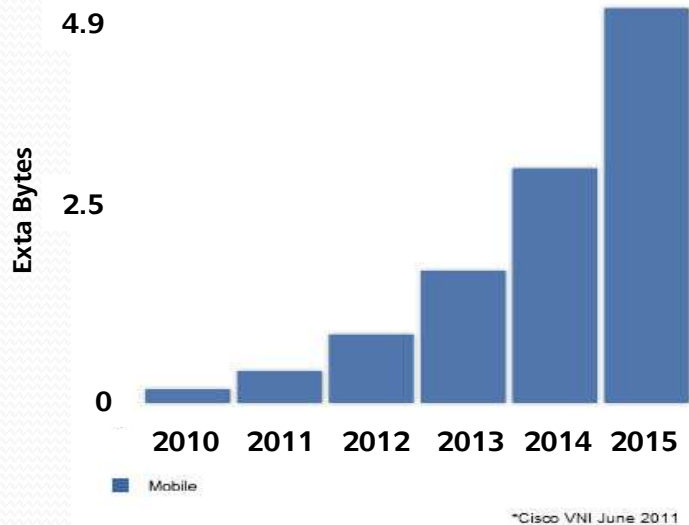

Why a New CFI? (2)

- Traditional P2P Ethernet needs one or two fibers per link
- Creates fiber congestion in the CO
- Need a solution that provides improved fiber utilization efficiency
 - Minimize deployment costs
 - Reduces maintenance errors



Why Now?

- Some business subscribers demand Ethernet services with higher bandwidths than currently available
- Some business subscribers demand physical layer security
- Some service providers have deployed P2P Ethernet, however, more efficient fiber usage is needed along with growing bandwidth demand for future applications
- Some service providers have delayed FTTx deployment due to fiber shortages
- Some wireless carriers have been unable to realize bandwidth capabilities of 3G/4G systems due to fiber shortages between base stations and CO
- A solution is needed soon

Why IEEE 802.3?

- IEEE 802.3 is the natural and rightful home to develop Ethernet Phy's
 - Eth WDM should be a new Ethernet Phy
 - Eth WDM should inherit all Ethernet standard features
- A solution from IEEE 802.3 WG is needed to avoid:
 - proliferation of proprietary solutions
 - development of operator-specific solutions
- IEEE 802.3 WG should promote network convergence
 - Eth WDM promotes network convergence



Ethernet WDM Aggregation Network Questions & Answers

Call For Interest



Ethernet WDM Aggregation Network Summary & Straw Polls

Call For Interest

Straw Polls

Should the 802.3 WG form a study group to develop a PAR and 5 Criteria for Ethernet WDM Aggregation Networks?

Anyone in Room

Yes: _____

No: _____

Abstain: _____

Straw Polls

_____ Number of people in the room

_____ I would participate in an Ethernet WDM Aggregation Network Study Group if formed

_____ My company would support participation in an Ethernet WDM Aggregation Network Study Group if formed



Thank You



Ethernet WDM Aggregation Network Backup and Reference

Call For Interest

Glossary

- ADC – analog to digital converter
- ASE – Amplified Spontaneous Emission
- AWG – Array Waveguide Grating
- BLS – Broadband Light Source
- CM – (Cable Modem)
- CMTS – (Cable Modem Termination System)
- CMU – (Coax Network Unit)
- CWDM – Coarse WDM
- DAC – digital to analog converter
- DSP – digital signal processor
- DWDM – Dense WDM
- eNB - (Evolved NodeB)
- EPC - (Evolved Packet Core)
- EPoC – (EPON over COAX)
- FM/FRM – Faraday Rotating Mirror
- PDV - Packet Delay Variation
- OFDM – Orthogonal Frequency Division Multiplexing
- RAN – Radio Access Network
- RSOA – Reflective Semiconductor Optical Amplifier

References

- 1 OFC 2012, K. Grobe et. al., OM3I.1 “Results from the OASE project”
- 2 Yankee Group 6th Dec. 2011, “2012 Mobility Predictions: A Year of Living Dangerously”
- 3 Heavy Reading 7/11
- 4 Communications Technology Jan 19 2012, “[Even With LTE, Work-Day Data Will Be Crunched](#)”
- 5 Infonetics 7/11
- 6 OECC 2009, Michael J. Wale, “[Technology Options for Future WDM-PON Access Systems](#)”
- 7 OFC2011, M. Presi & E. Ciaramella, OPM4 “Stable self-seeding of R-SOAs for WDM-PONs”
- 8 Huawei internal experiments
- 9 Wikipedia [http://en.wikipedia.org/wiki/Jakob_Nielsen_\(usability_consultant\)](http://en.wikipedia.org/wiki/Jakob_Nielsen_(usability_consultant))
- 10 Nielson Jakob’s Alert Box: <http://www.useit.com/alertbox/980405.html>
- 11 CISCO VNI 2011
- 12 Wireless World 15 Feb 2012 “[Cisco forecasts 18-fold increase in mobile data by 2016](#)”

What should the Study Group Look at when determining the PAR and 5 Criteria?

- Project Objectives:
 - Discuss data rate(s) and link types accommodated
 - Discuss wavelength plan (number & spacing of wavelengths / links)
 - Discuss transmission distance
 - Determine PMD only or include PCS/PMA
 - Discuss the number of power budget classes, target power budget values, with or without FEC, etc.
- Reuse existing MAC
- Minimal changes to MAC Control definitions (attributes / objects necessary to manage new PHYs).