

MDI Lane Assignments for 400GBASE-SR4.2

Jonathan Ingham - Foxconn Interconnect Technology

John Petrilla - Foxconn Interconnect Technology

Paul Kolesar - CommScope

IEEE P802.3cm Task Force Meeting

September 2018

Background

Signal mapping: 400GBASE-SR4.2 Optical Lane Assignments (1)

•Form factors that may support 400GBASE-SR4.2 include QSFP-DD and OSFP and for these cases the 12 fiber MPO optical connector is expected.

•The ferrule labels in the top figure are consistent with those used in Figure 33 and Table 10 of the QSFP-DD Hardware Specification and with the OSFP MSA Specification.

•The figures shows the proposed mapping of signals between the electrical and optical connector. Here, for example, the optical signal Tx1 corresponds to the electrical signal on the electrical connector contacts Tx1p and Tx1n.

•The bottom figure shows the renaming of the ferrules as proposed above for 400GBASE-SR4.2. The signal names on the optical connector are included for reference.

•The mapping is completely compatible with the installed cable plant for 40GBASE-SR4 and 100GBASE-SR4 and for the same form factors permits 400GBASE-SR4.2 to plug into the same sockets and hosts as, e.g. 400GBASE-DR4.

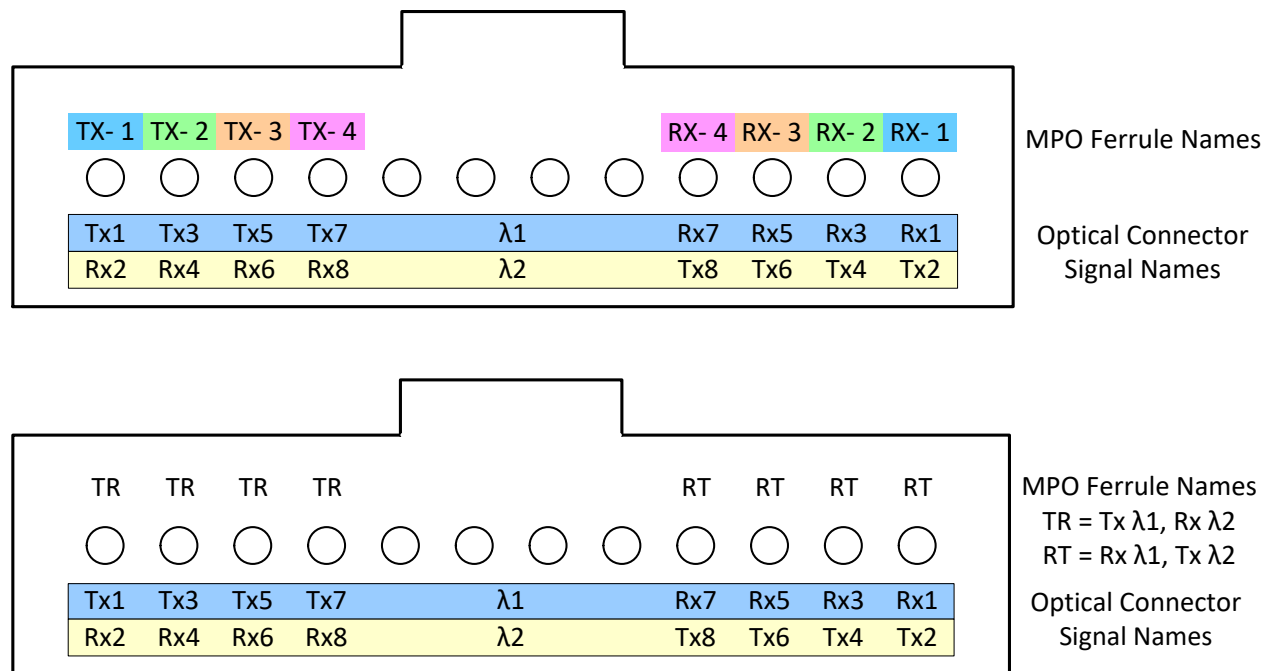

•The figures are color coded to indicate the mapping of the two wavelengths (λ1, λ2) with the signals. See the following page for additional details regarding the fiber mapping between the MPO connector and duplex connectors.

•Note that each ferrule and associated fiber carries two signals, one of each wavelength and each in a different direction.

Signal mapping: 400GBASE-SR4.2 Optical Lane Assignments (2)

•The top figure repeats the top figure from the previous page and the bottom picture shows the fiber mapping between the MPO connector and four separate duplex connectors.

•The MPO-duplex mapping is identical to industry practice where, for example, four 10GBASE-SR transceivers are aggregated within a QSFP form factor.

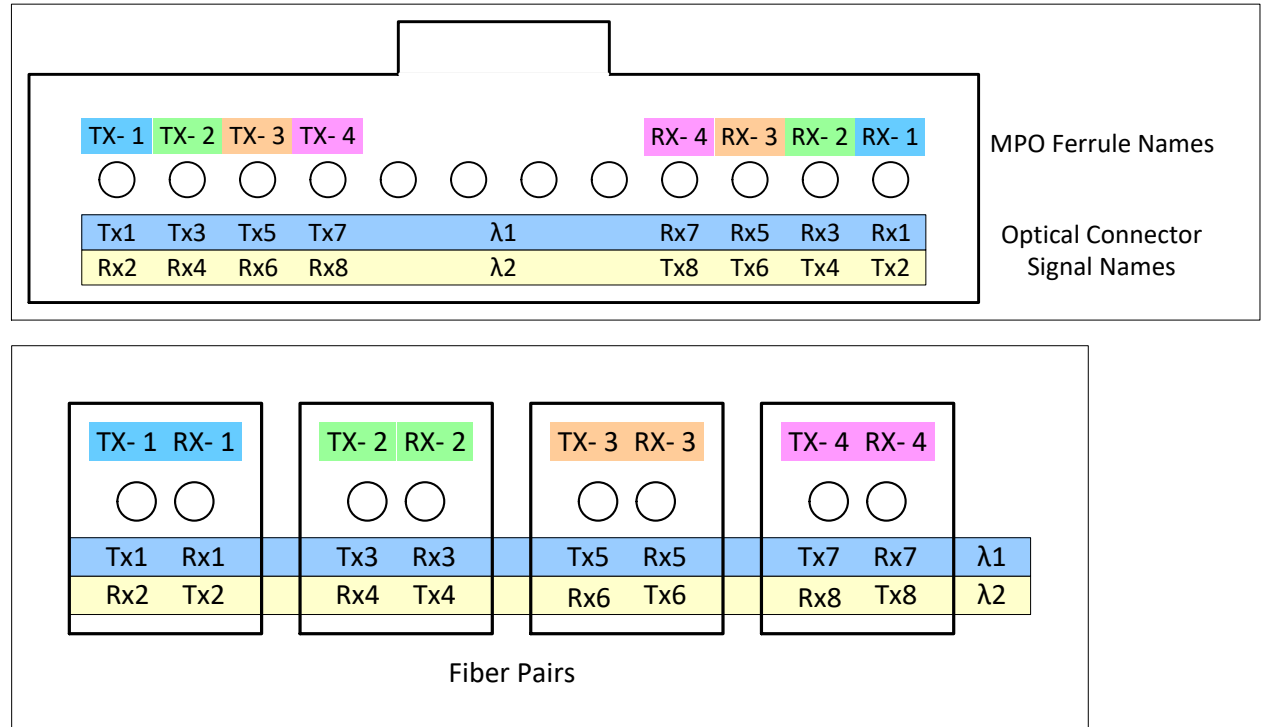

•The figures are color coded to indicate the mapping of the two wavelengths (λ_1 , λ_2) with the signals and the fiber mapping between the MPO connector and four separate duplex connectors.

•Note that each ferrule and associated fiber carries two signals, one of each wavelength and each in a different direction.

Comparison of traditional SR4 and SR4.2 MDI lane assignment figures

Example MDI lane assignment figure from 40GBASE-SR4, 100GBASE-SR4, 200GBASE-SR4

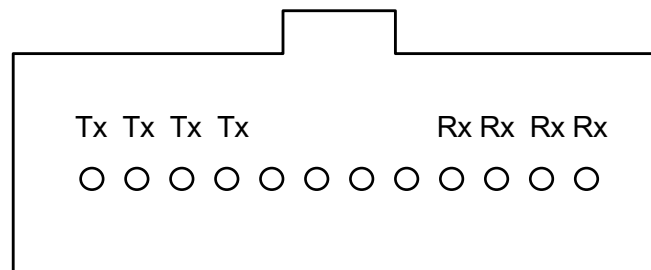

Proposed MDI lane assignment figure for 400GBASE-SR4.2

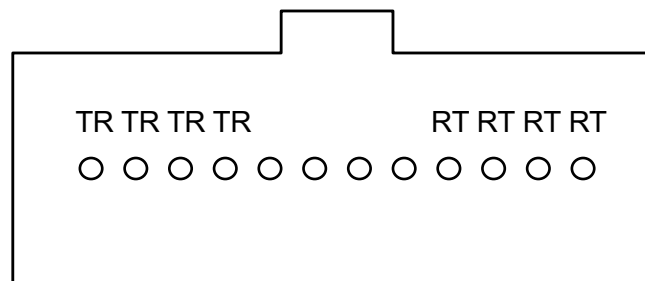

Legend

TR = Transmitter λ 1, Receiver λ 2

RT = Receiver λ 1, Transmitter λ 2

Connectivity requirement - TR lanes connect to RT lanes

Proposed Standard Content

Proposed content for 802.3cm (1 of 4)

200.y.z Medium Dependent Interface (MDI)

The 400GBASE-SR4.2 PMD is coupled to the fiber optic cabling at the MDI. The MDI is the interface between the PMD and the “fiber optic cabling” (as shown in Figure 200-c). The 400GBASE-SR4.2 PMD is coupled to the fiber optic cabling through one connector plug into the MDI optical receptacle as shown in Figure 200-e. Example constructions of the MDI include the following:

- a) PMD with a connectorized fiber pigtail plugged into an adapter;
- b) PMD receptacle.

Note to the editor: Figure 200-c, not shown in this contribution, is the traditional fiber optic cabling model as shown, for example, in Figure 95-6.

Proposed content for 802.3cm (2 of 4)

200.y.z.a Optical lane assignments

The eight transmit and eight receive optical lanes of 400GBASE-SR4.2 shall occupy the positions depicted in Figure 200-d when looking into the MDI receptacle with the connector keyway feature on top. The interface contains 8 active positions within 12 total positions. The four center positions are unused. The TR optical lanes occupy the leftmost four positions. The RT optical lanes occupy the rightmost four positions. Transmit wavelengths in the range defined for λ_1 and receive wavelengths in the range defined for λ_2 shall use TR positions. Receive wavelengths in the range defined for λ_1 and transmit wavelengths in the range defined for λ_2 shall use RT positions.

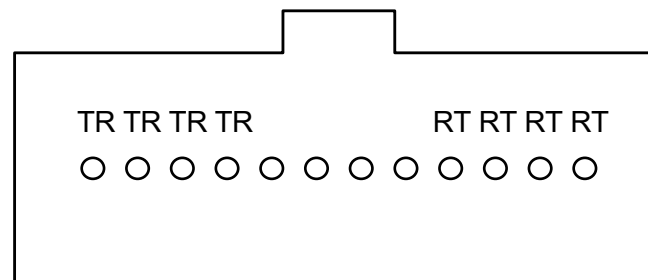

Figure 200-d—Optical lane assignments

Proposed content for 802.3cm (3 of 4)

200.y.z.b MDI requirements

The MDI shall optically mate with the compatible plug on the optical fiber cabling. The MDI adapter or receptacle shall meet the dimensional specifications for interface 7-1-3: *MPO adapter interface - opposed keyway configuration*, or interface 7-1-10: *MPO active device receptacle, flat interface*, as defined in IEC 61754-7-1. The plug terminating the optical fiber cabling shall meet the dimensional specifications of interface 7-1-4: *MPO female plug connector, flat interface for 2 to 12 fibers*, as defined in IEC 61754-7-1. Figure 200-e shows an MPO female plug connector with flat interface, and an MDI. The MDI connection shall meet the interface performance specifications of IEC 61753-1 and IEC 61753-022-2 for performance grade Bm/2m.

Proposed content for 802.3cm (4 of 4)

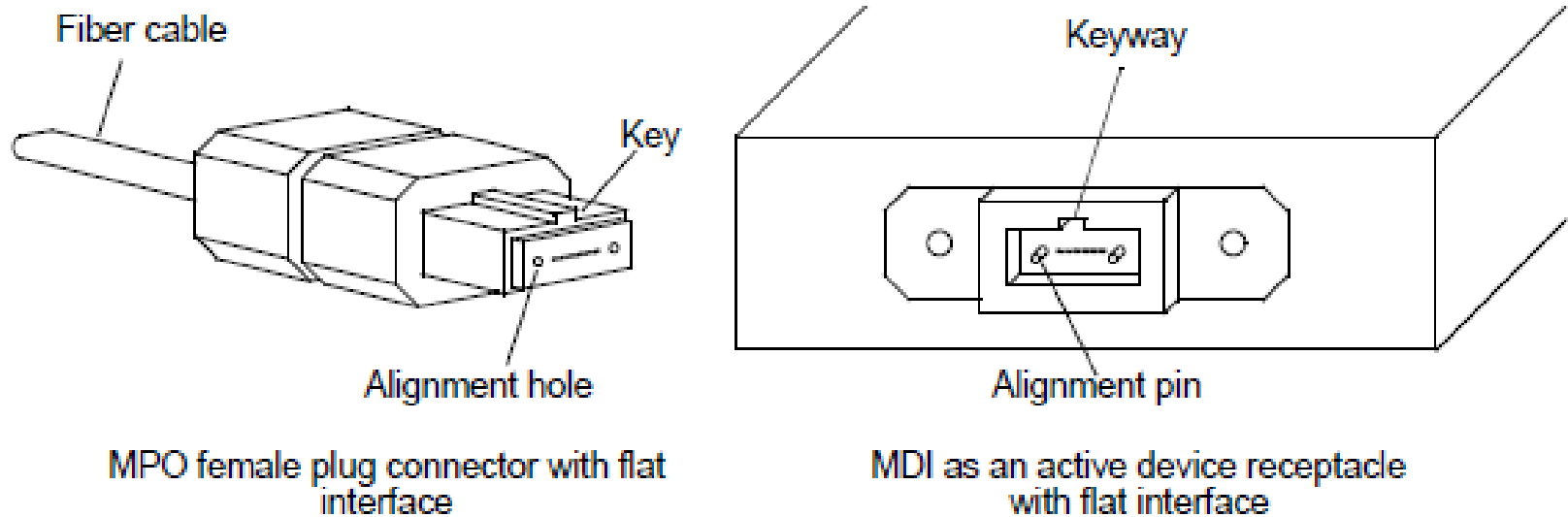

Figure 200-e—MPO female plug with flat interface and MDI active device receptacle with flat interface

Thank you.

Q&A