SPE Multidrop Enhancements Mixing Segment Baseline Motions

March 2021

Chris DiMinico/MC Communications/PHY-SI LLC/SenTekse/Panduit
cdiminico@ieee.org
Bob Voss/Paul Wachtel/Panduit

Contributors

- **Wojciech Koczwarra, Scott Griffiths, David Brandt, Sebastian Konewko - Rockwell**
- **Paul Wachtel, Bob Voss - Panduit**
- **Steffen Graber - Pepperl + Fuchs**
- **Piergiorgio Beruto - Canovatech**
- **George Zimmerman - CME Consulting, Inc.**

IEEE P802.3da Baseline Motions

Move to approve:

MOTION 1: Adopt IL limit (with the equation 147-3 with a 10% increase (that is what 147.8.1 references))

M: George Zimmerman

S: Chris DiMinico

Motion 2: Adopt RL limit (with the equation 147-4 with 50 ohm reference impedance as in 147.8.2)

M: George Zimmerman

S: Chris DiMinico

MOTION 3: Adopt the fitted IL, using the method of 93A.3 shall comply to Equation 147-3 over the frequency band from 0.3 MHz (fmin) to 40 Mhz (fmax), with a frequency spacing TBD (delta F).

(note, 93A.3 requires you specify fmin, fmax, and delta F)

M: George Zimmerman

S: Chris DiMinico

Motion 4: Adopt IL/RL editors note.

“Editor’s note (to be removed prior to working group ballot): the Mixing Segment parameters (IL and RL) represent a construction achievable with 50 m of 18 AWG cabling, 16 nodes attached with 30 cm drop cable, and MDI specifications given in 200.8, that will support operation of a PHY similar to clause 147. The RL and IL limits do not not address PoDL impedances for further study. The IL limit does not bound ILD deviation for futher study. When PHY baselines are chosen, it is desirable for this performance to be exceeded, and these parameters should be revisited.”

M: George Zimmerman

S: Chris DiMinico

IEEE P802.3da Baseline Motions

MOTION 5: Adopt MDI impedance parameters (as Table 147-4 and relevant text from 147.9.2)

M: George Zimmerman

S: Chris DiMinico

MOTION 6: Adopt text under Mixing segment characteristics (as 147.8 Mixing segment characteristics)

“A mixing segment is specified based on 1.02mm (18 AWG) cabling that supports up to at least 16 nodes and 50 m in reach. PHYs can be attached in-line with the trunk or at the end of stubs with a length of up to 30 cm with a minimum spacing of 60 cm. If stubs are used, spacing between stubs should be at least twice the stub length. Larger PHY count and/or reach can be achieved provided the mixing segment specifications are met. “

“Editor’s note (to be removed prior to working group ballot) Identification of what we mean by ‘PHYs attached in-line’ needs to be added. Figure 147-20 does not adequately illustrate; Figure to be added to align with text.

M: Bob Voss

S: Chris DiMinico

IEEE P802.3da Mixing Segment

Configurations of 8 nodes with 60 cm separation and drop cables of 30 cm clumped at both ends of a 50 m and 25 m trunk cable used to support mixing segment limits.

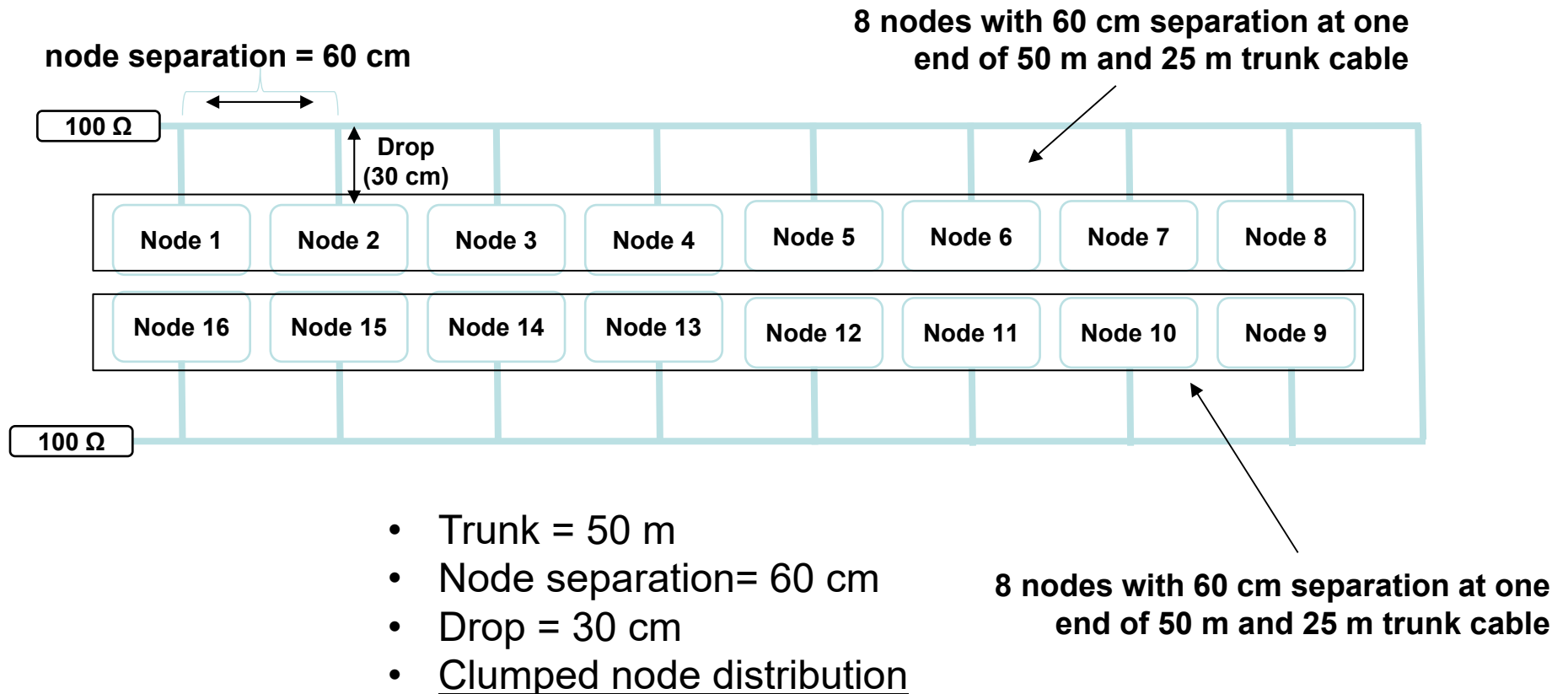

802.3da – Mixing Segment IL

- 147.8.1 Mixing Segment Insertion loss*1.1 (10% increase)

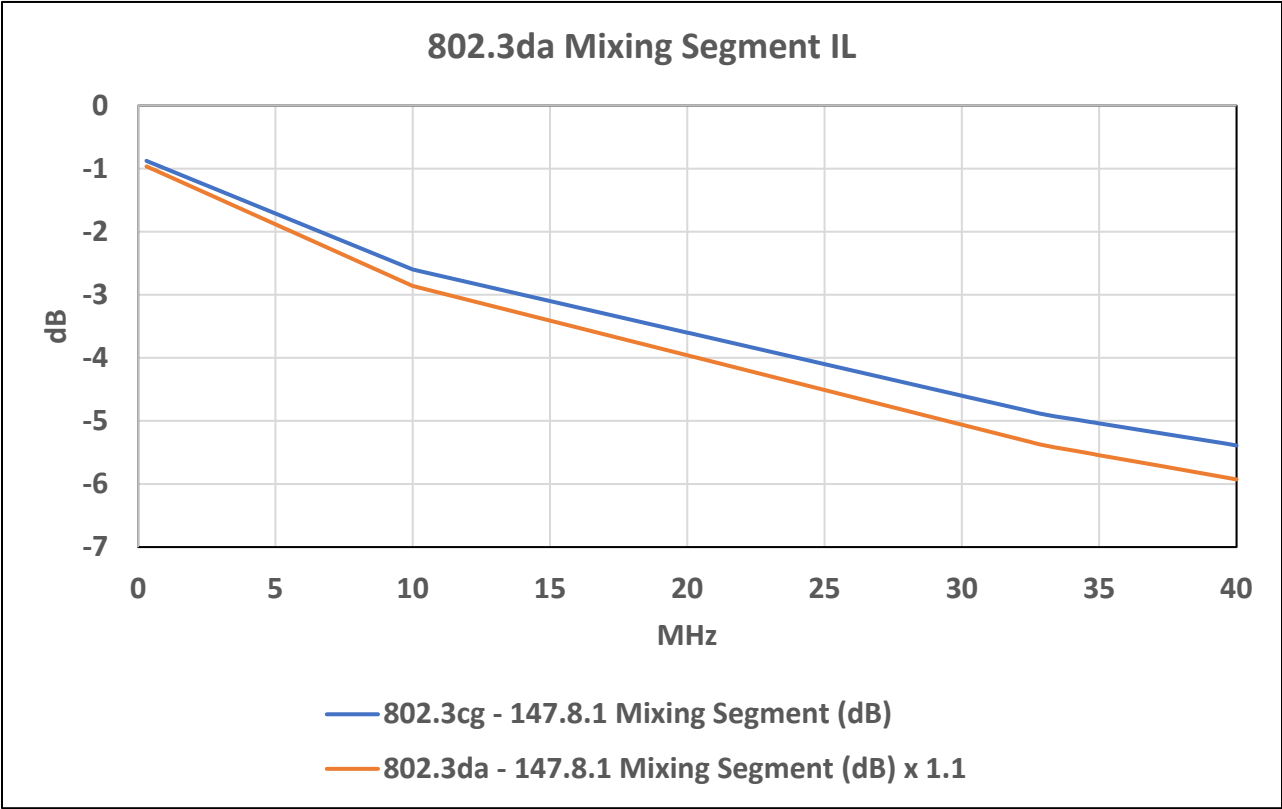

IEEE P802.3da Mixing Segment – RL

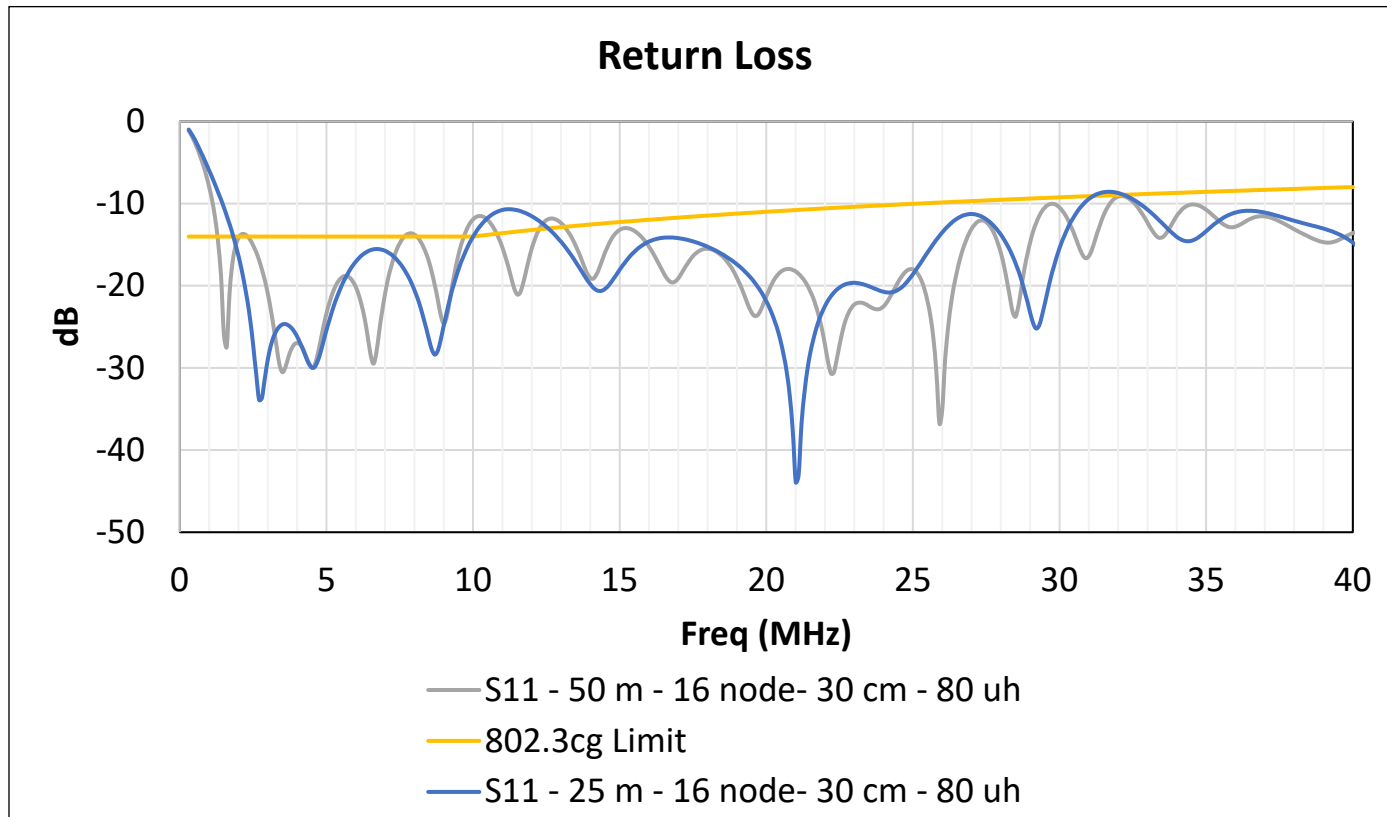

- Trunk = 50 m
- Node separation= 60 cm
- Drop = 30 cm
- clumped node distribution

IEEE P802.3da Mixing Segment - IL

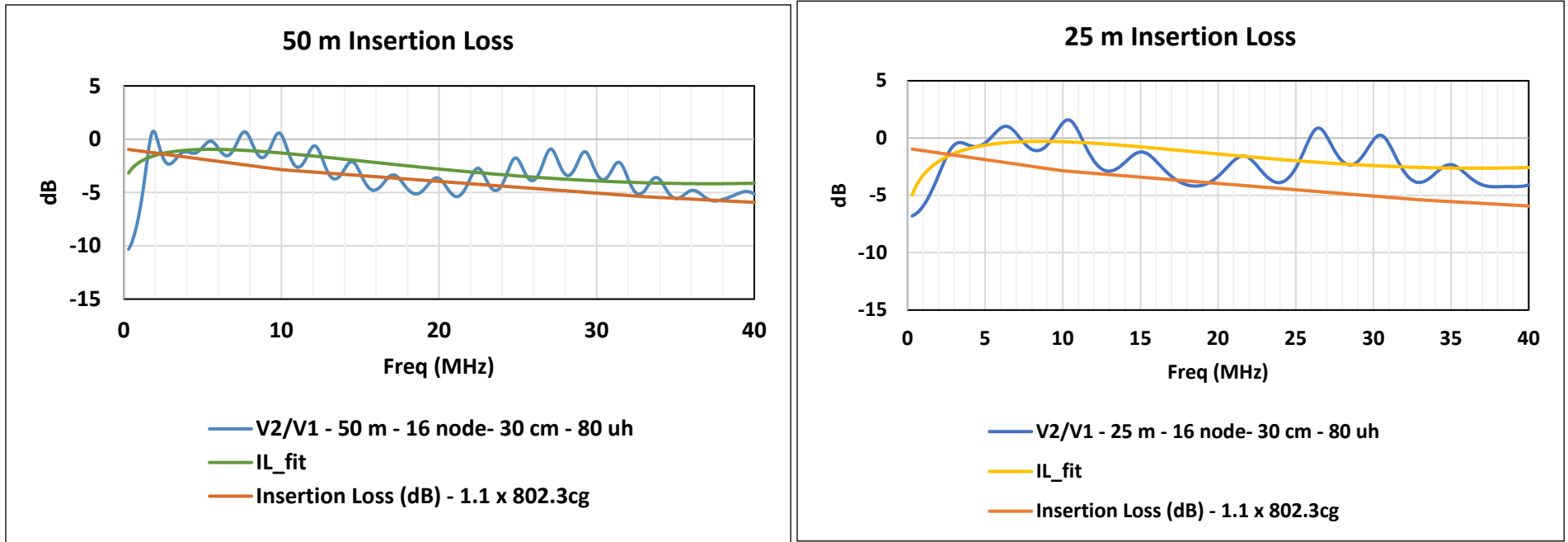

- Trunk = 50 m
- Node separation= 60 cm
- Drop = 30 cm
- clumped node distribution

802.3da MDI electrical specification

-MDI impedance limit parameters

Parameter name	Unit of measure	Minimum value	Maximum value
R	k Ω	10	—
L	μ H	80	—
C_{tot}	pF	—	180
C_{node}	pF	—	15

Source: IEEE Std 802.3cg™-2019

Fitted Insertion Loss

IEEE Std 802.3bj™-2014

93A.3 Fitted insertion loss

The fitted insertion loss as a function of frequency is given by Equation (93A-51).

$$IL_{fitted}(f) = a_0 + a_1\sqrt{f} + a_2f + a_4f^2 \quad (93A-51)$$

Denote the insertion loss, in dB, measured at frequency f_n as $IL(f_n)$. Given the insertion loss measured at N uniformly-spaced frequencies from start frequency f_{min} to stop frequency f_{max} with step no larger than Δf , the coefficients for the fitted insertion loss shall be calculated as follows.

Define the weighted frequency matrix F using Equation (93A-52).

$$F = \begin{bmatrix} 10^{-IL(f_1)/20} \sqrt{f_1} 10^{-IL(f_1)/20} & f_1 10^{-IL(f_1)/20} & f_1^2 10^{-IL(f_1)/20} \\ 10^{-IL(f_2)/20} \sqrt{f_2} 10^{-IL(f_2)/20} & f_2 10^{-IL(f_2)/20} & f_2^2 10^{-IL(f_2)/20} \\ \dots & \dots & \dots \\ 10^{-IL(f_N)/20} \sqrt{f_N} 10^{-IL(f_N)/20} & f_N 10^{-IL(f_N)/20} & f_N^2 10^{-IL(f_N)/20} \end{bmatrix} \quad (93A-52)$$

Define the weighted insertion loss vector L using Equation (93A-53).

$$L = \begin{bmatrix} IL(f_1) 10^{-IL(f_1)/20} \\ IL(f_2) 10^{-IL(f_2)/20} \\ \dots \\ IL(f_N) 10^{-IL(f_N)/20} \end{bmatrix} \quad (93A-53)$$

The fitted insertion loss coefficients are then given by Equation (93A-54).

Supplemental

Distribution Topologies

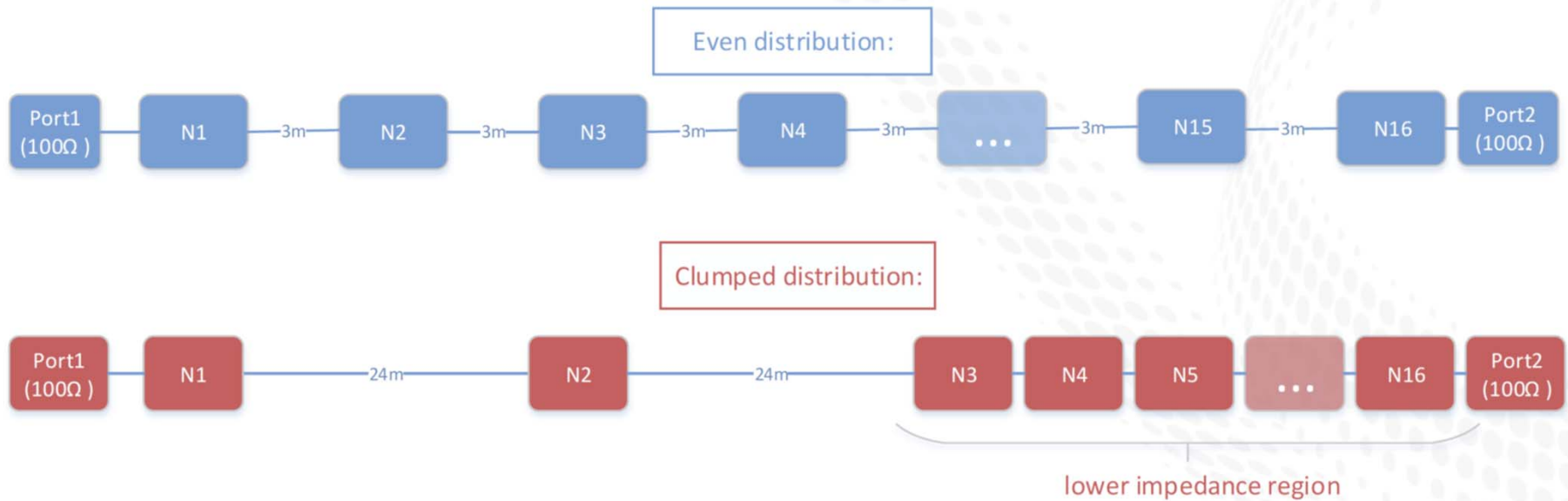

Source: Wojciech Koczwar, Scott Griffiths, David Brandt, Sebastian Konewko - Rockwell

Clumped Distribution - 50 m

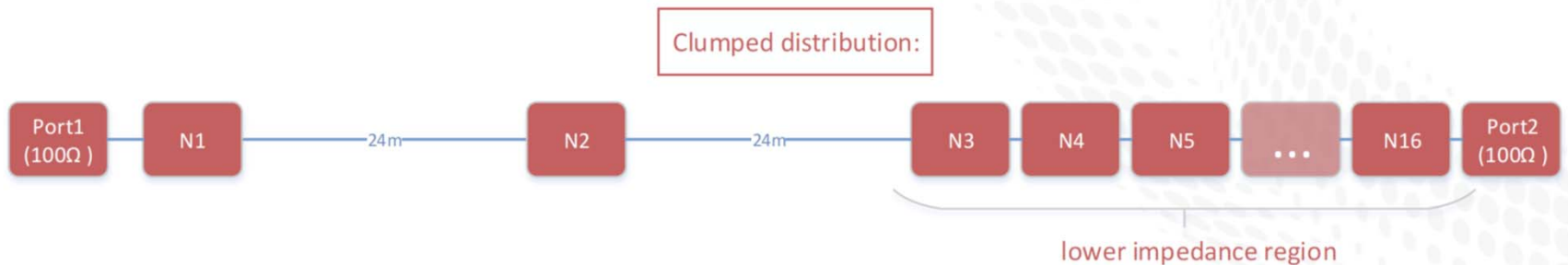

Clumped, 80uH PoDL, Tx node 1, 30cm stubs, 60cm spacing

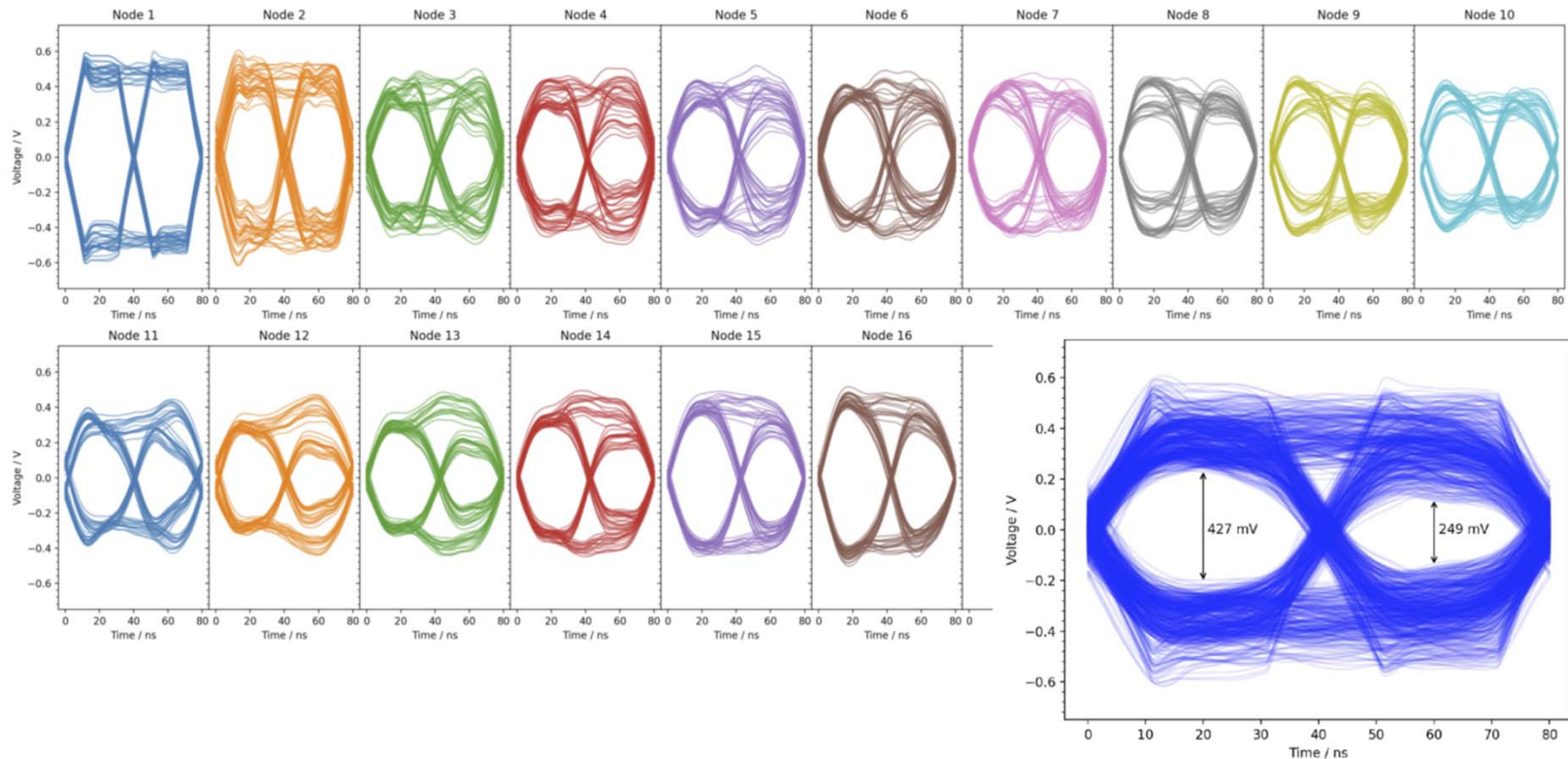

Source: Wojciech Koczwar, Scott Griffiths, David Brandt, Sebastian Konewko - Rockwell
10 Mb/s SPMD Enhancement TG

25 m 18 AWG 8 node – Even Distribution

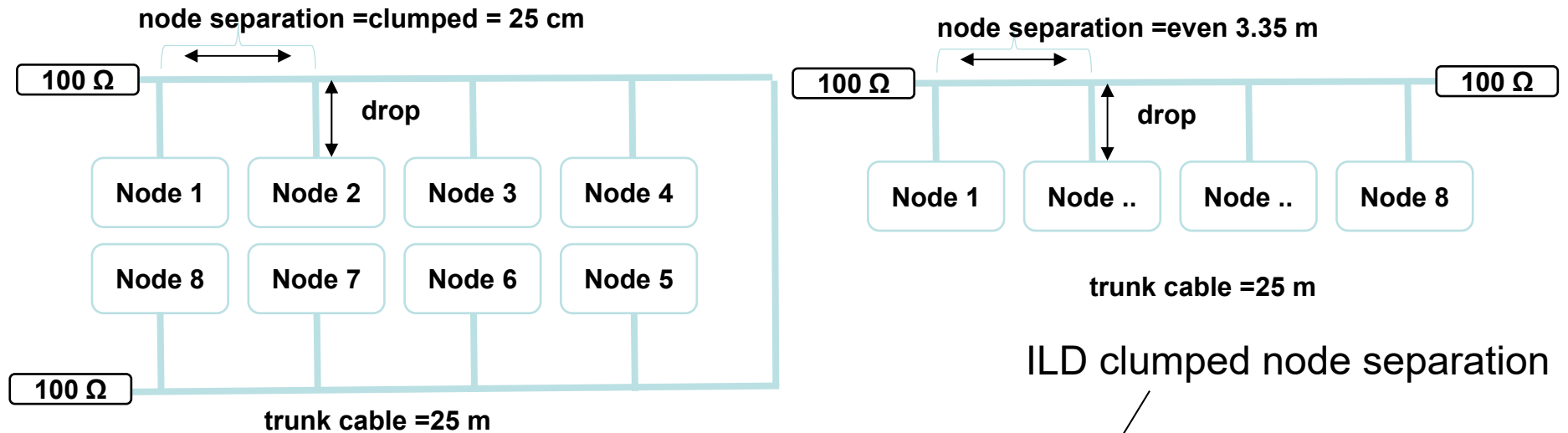

Even distributions can yield deeper IL suck outs but less in band ILD as observed in impacting eye

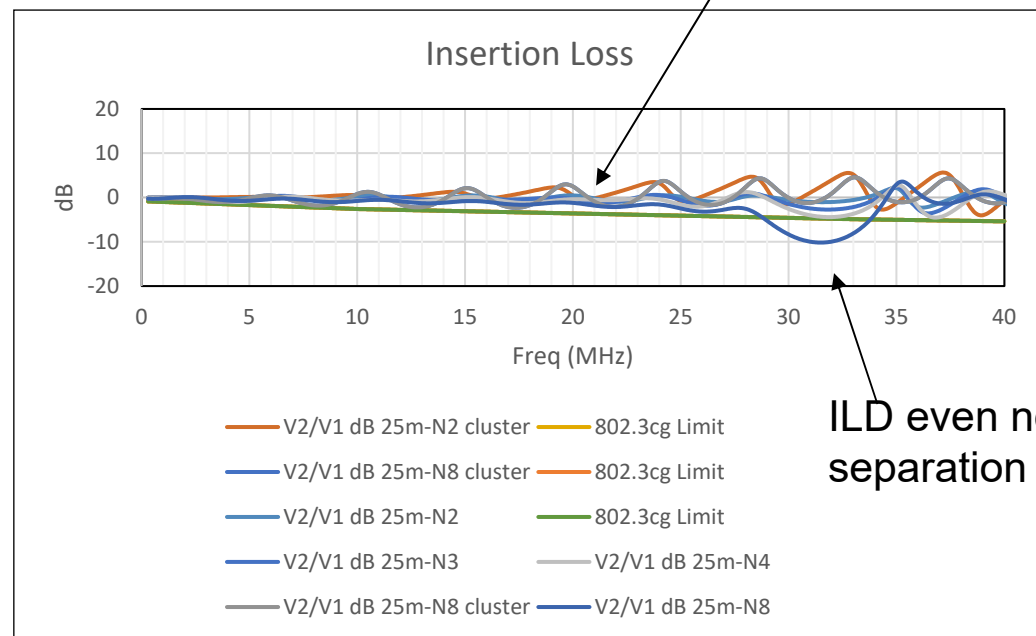

50m 18 AWG 8 node – Even Distribution

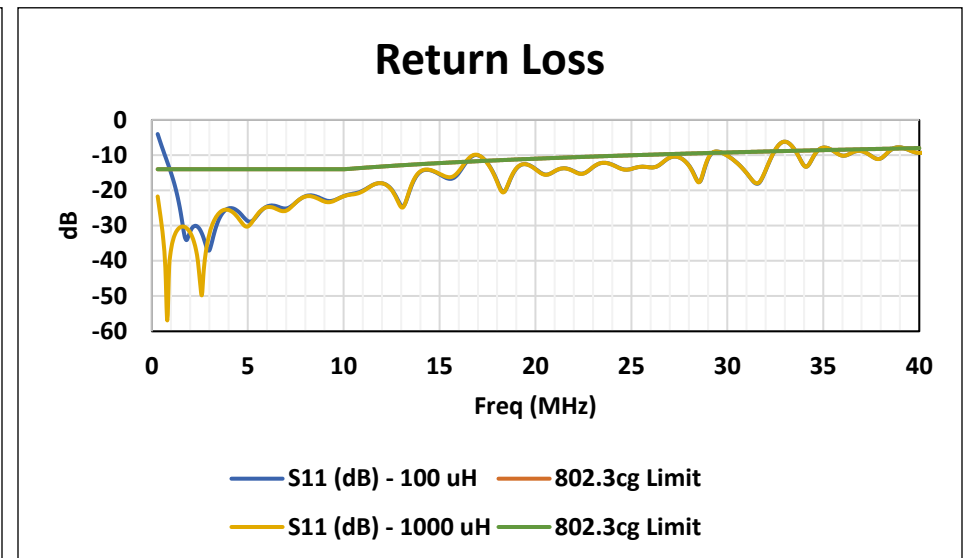
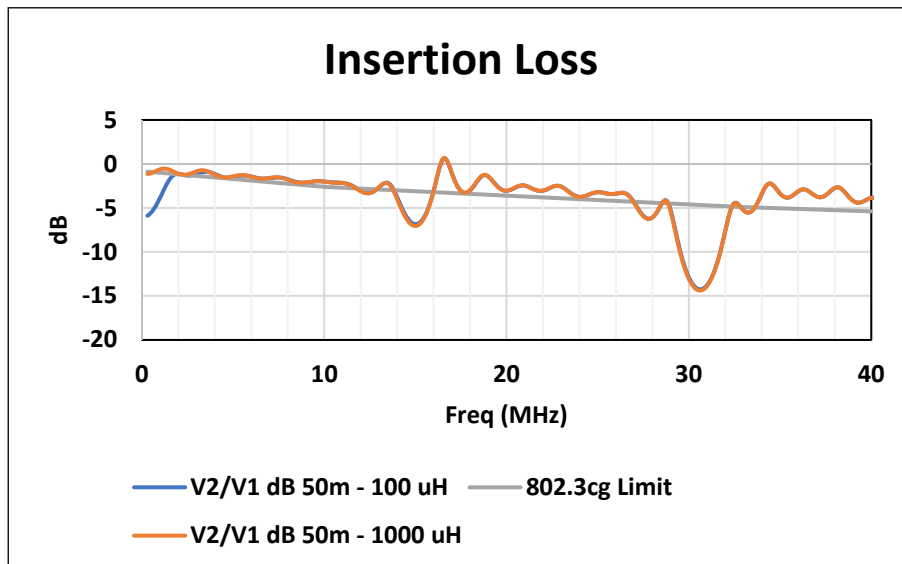
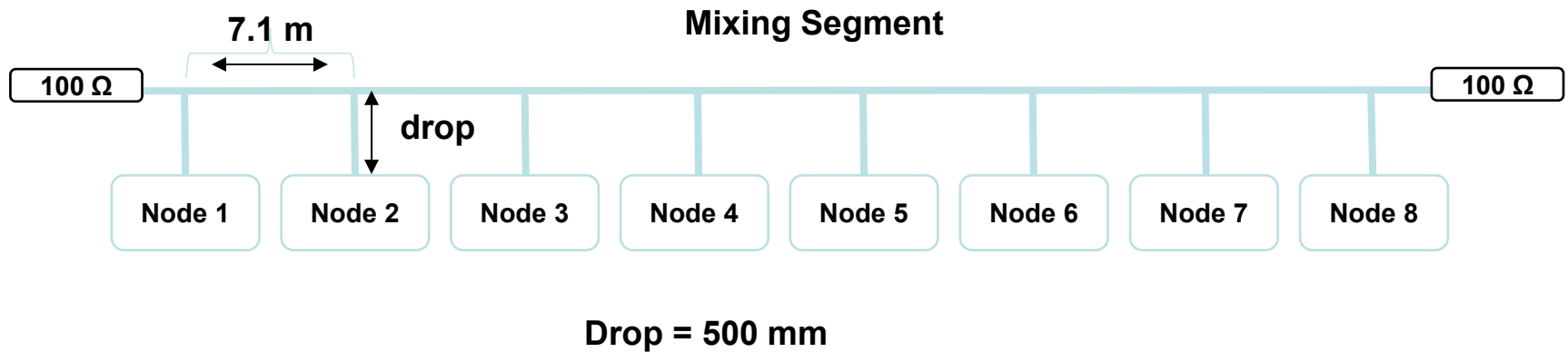

Mixing Segments - Type 10BASE2-10BASE5

- 10BASE2 and 10BASE5 mixing segments have constraints on reach, number of nodes, and minimum spacing between nodes.

- **Type 10BASE2 applications**

- Maximum unrepeaters cable segment 185 m
- Maximum number of MAUs per segment 30
- Connector type Type BNC "T"
- Total Segment Resistance 10 ohm
- MAU separation 0.5 m
- Connection shunt capacitance 8 pF

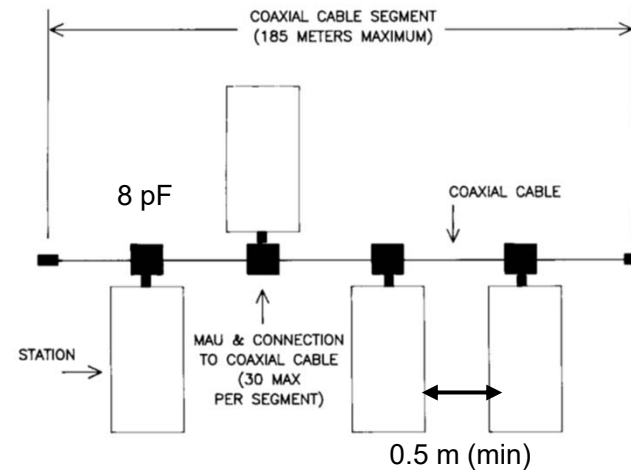
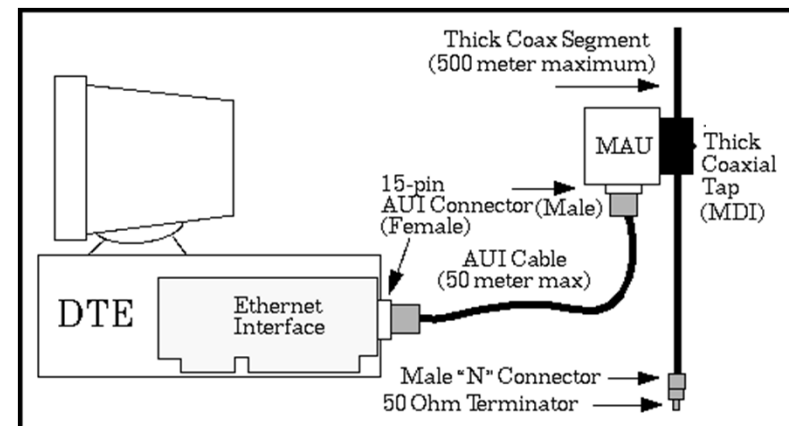

Figure 10-8—The minimum system configuration

In order to maintain reflections at an acceptable level, the minimum length cable section shall be 0.5 m.

- **Type 10BASE5 applications**

- Maximum unrepeaters cable segment 500 m
- Maximum number of MAUs per segment 100
- Connector type Type N or coaxial "tap"
- Total Segment Resistance 5 ohm
- MAU separation 2.5 m
- Connection shunt capacitance 4 pF



Node separation versus MHz

