

Clause 104 Maintenance Requests

Heath Stewart

Karl Peterson



Overview

Item	Updated?
$V_{\text{sig_disable}}$ and V_{PUP} Tracking	Yes
CRM $V_{\text{REPORT_PD}}$	No
DO_CLASSIFICATION: present_iwakeup <= FALSE	No
Post-sleep Classification Hook	No

V_{sig_disable} and V_{PUP} Tracking Proposed Remedy

Table 104-5—Valid PD detection signature characteristics, measured at PD PI

Parameter	Conditions	Min	Max	Unit
V _{good}	7mA < I _{PD} < 17mA, PD exiting RESET state	4.05	4.55	V
I _{signature_limit}	V _{PD} < V _{sig_disable_max}	—	24	mA
V _{sig_disable}	V _{PD} rising	4.6	5.75	V
V _{sig_enable}	V _{PD} falling	3.6	4.3	V

Table 104-8—SCCP electrical requirements

Item	Parameter	Symbol	Unit	Min	Max	PSE/ PD Type	Additional information
1	PSE Pull-up Voltage (Classes 0 to 9)	V _{PUP}	V	V _{good_PSE_max}	5	All	See Table 104-3
	PSE Pull-up Voltage (Classes 10 to 15)				5.5		

Technical, 802.3bu, Page 54, Table 104-5

Comment

Transitions from DO_CLASSIFICATION to MDI_POWER1 pragmatically occur between V_{PUP,max} and V_{sig_disable,max}. In 802.3bu, for Classes 0-9, this decision region spans 0.75V. In 802.3cg, for Classes 10-15, V_{PUP} changed to 5.5V, without a corresponding change to V_{sig_disable}. The resulting decision region is reduced to 0.25V.

Suggested Remedy

Modify 104-5 as follows, splitting V_{sig_disable} into two rows

Table 104-5—Valid PD detection signature characteristics, measured at PD PI

Parameter	Conditions	Min	Max	Unit
V _{good}	7mA < I _{PD} < 17mA, PD exiting RESET state	4.05	4.55	V
I _{signature_limit}	V _{PD} < V _{sig_disable_max}	—	24	mA
V _{sig_disable, Classes 0 to 9}	V _{PD} rising	4.6	5.75	V
V _{sig_disable, Classes 10 to 15}	V _{PD} rising	6.0	7.5	V
V _{sig_enable}	V _{PD} falling	3.6	4.3	V

Need to Address: **Consensus**
 Solution Form: **Consensus**
 Solution Details: **Consensus**

Cable Resistance Measurement and $V_{\text{Report_PD}}$

- ▶ For CRM, the PD reports its voltage to the PSE so the PSE can perform a $\Delta V/\Delta I$ calculation. Accuracy is +/-20mV.
- ▶ The existing +/-20mV tolerance requirement does not allow power coupling network resistance to be, optionally, measured
 - Removing the negative tolerance requirement allows greater design flexibility
 - Regardless any measurement error is capped by $R_{\text{Cable, max}}$ and there is no risk to interoperability

$$R_{\text{Cable}} = \min(R_{\text{Cable_initial}} \times K_{\text{RMF}}, R_{\text{Loop(max)}}) \Omega \quad (104-4b)$$

- ▶ Change +/- to +

Table 104-10—VOLT_INFO register table

Bit(s)	Name	Description	R/W ^a
b[15:8]	Reserved	Value always 0	RO
b[7:0]	Voltage at PD PI during Presence Pulse	+/- 20 mV tolerance, 10 mV per LSB	RO

Need to Address: **Consensus**
 Solution Form: **Consensus**
 Solution Details: **Consensus**

^aRO = Read only

DO_CLASSIFICATION: present_iwakeup

Technical, 802.3bu, Page 53, Figure 104-8

Comment

The PD state machine, as written, requires present_iwakeup to be TRUE in DO_CLASSIFICATION based on an assignment derived from DO_DETECTION. During classification the PD is engaged in SCCP signaling and cannot simultaneously present the iwakeup signature.

Suggested Remedy

Modify Figure 104-8 as follows, specifically setting present_iwakeup to FALSE in DO_CLASSIFICATION.

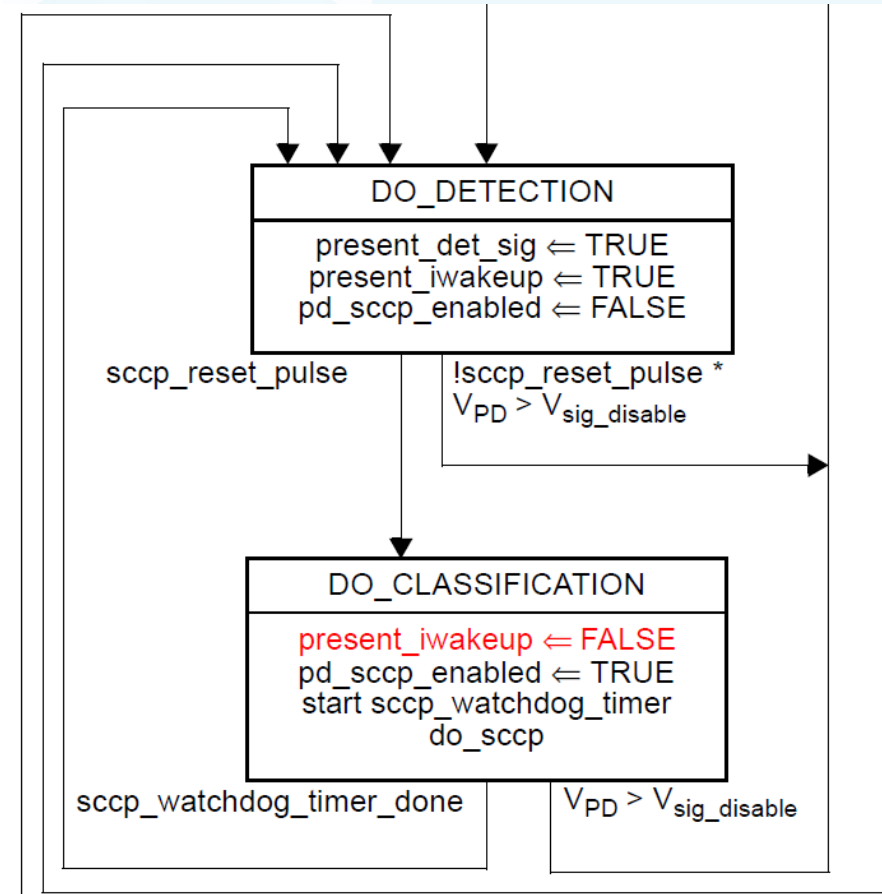

Need to Address: Consensus

Solution Form: Consensus

Solution Details: Consensus

[04/27/21] Post-sleep Classification

Technical, 802.3bu, Page 53, Figure 104-8

Comment

The PD state machine, as written, does not allow a PD to respond to SCCP classification on PD_SLEEP exit.

Suggested Remedy

Change

wakeup

TRUE: the PD requires the full operating voltage at the PI.

FALSE: the PD is ready to go to sleep.

To

wakeup

An implementation specific variable enabling the PD to request wakeup.

TRUE: the PD requires the full operating voltage at the PI.

FALSE: the PD is ready to go to sleep.

Consider: FALSE: the PD is ready to go to sleep or is not otherwise requesting full operating voltage.

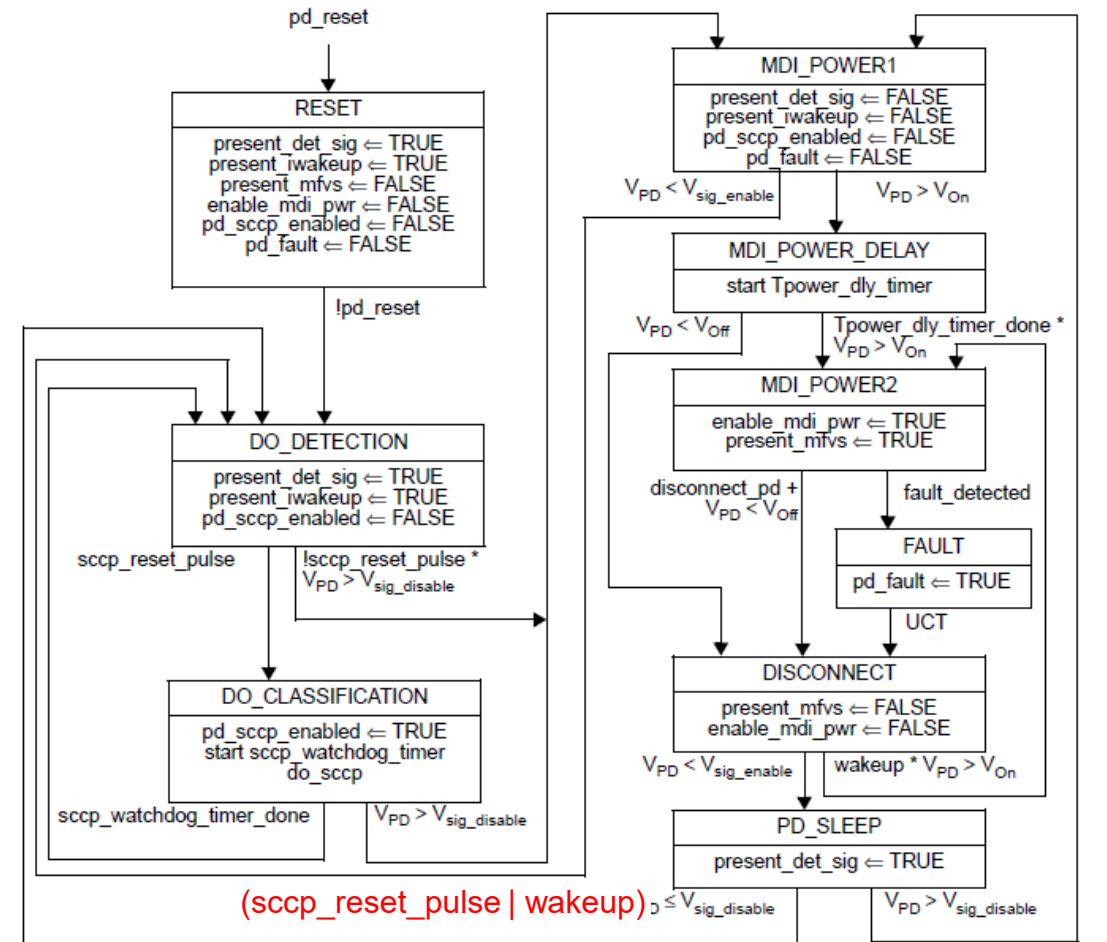

(`sccp_reset_pulse | wakeup`) $\leq V_{sig_disable}$ $V_{PD} > V_{sig_disable}$

Need to Address: Consensus

Solution Form: Needs Review

Solution Details: Needs Review