

# Copper Cable Channel Characteristics

Sam Kocsis  
Michael Rowlands  
Ali Hammoodi  
Jose Paniagua

**Amphenol**  
COMMUNICATIONS SOLUTIONS



# Contributors

- Jim Weaver, Arista Networks
- Jason Chan, Arista Networks
- Regee Petaja, Broadcom
- Chi Tu, Broadcom

- Goal: To advance the progress of the copper cable objective towards a baseline with new channel contributions
  - Based on Passive Direct Attach Copper (DAC) implementations
  - Demonstrating 1m physical reach (and possibly beyond)
  - Using OSFP MDI, from OSFP MSA
  - *Focused on the channel, not the component*
- Presentation of the new channel models to the Task Force
- Brief assessment of the performance/quality of the new channels
- Compatibility of the copper cable objective with the anticipated “KR” objective and supporting analysis
  - [mellitz 3dj elec 04a 230504](#)

# CR Copper Cable Objective

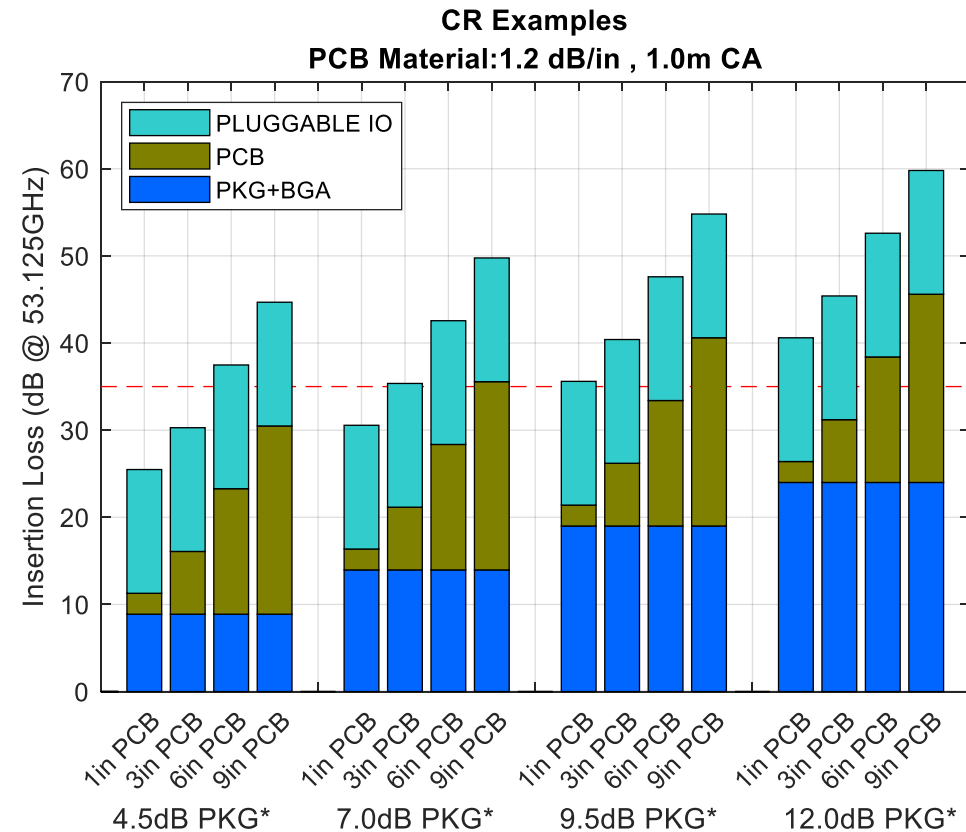
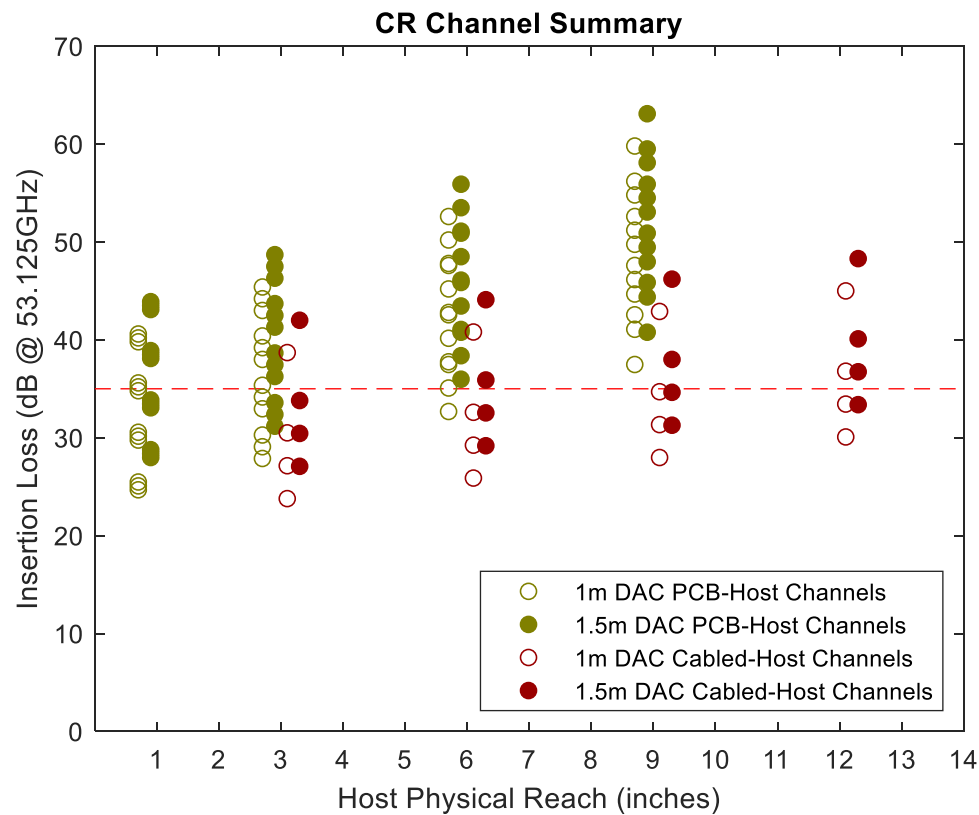

- Plots above from [kocsis\\_b400g\\_01a\\_210826](#)
- CR objective was proposed with the perspective of a “die-to-die” scheme

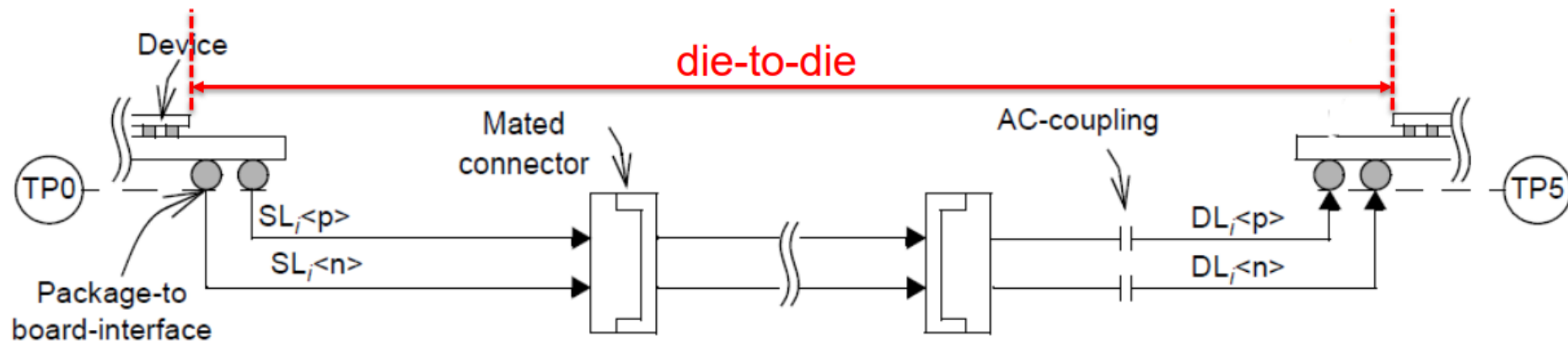
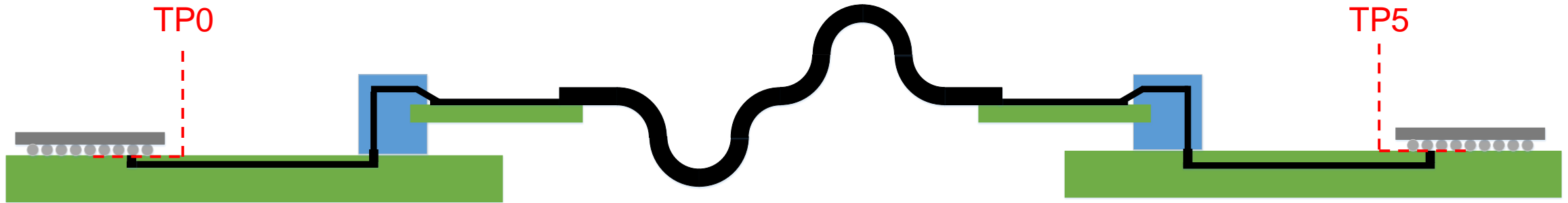

- Contributed channels align with estimates from [kocsis\\_b400g\\_01a\\_210826](#)
- Contributed channels compatible with the “die-to-die” scheme

# CR Copper Cable Channel Configurations

Configuration	TP0 Side Host Loss (dB @53.125GHz)	Copper Cable Length (m)	TP5 Side Host Loss (dB @53.125GHz)	TP0-TP5 Loss (dB @53.125GHz)
1	8	1	8	30.75
2	10	1	10	34.51
3	4	1.5	4	26.65
4	3	1	9	26.74
5	9	1	3	26.74

- Configurations 1 and 2 represent symmetric, switch-switch links
- Configuration 3 represents case with physical reach >1.5m
- Configurations 4 and 5 represent asymmetric, switch-server links

*Package length adjusted to maintain 40dB “die-to-die” in each analysis*

# CR Copper Cable Channel Model Components

## Host 1 BGA Grid

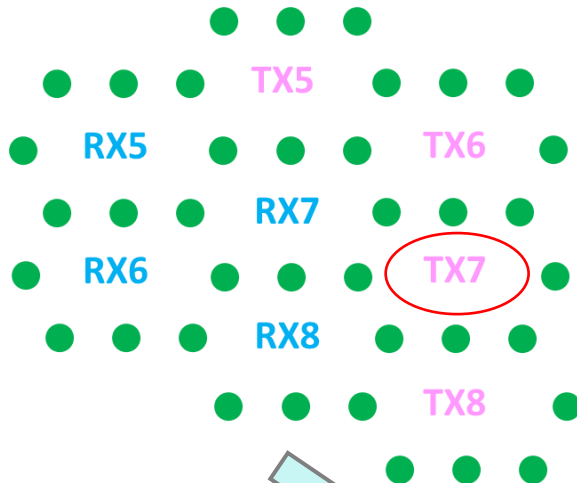

## BGA breakout model from

[weaver\\_3dj\\_01\\_2303](#)

- 3mm PTH depth
- 8mil vias, 5mil stubs

Copper cable modeled at room temperature

- 26AWG
- “Uncorrelated” intra-pair skew

## Host 2 BGA Grid

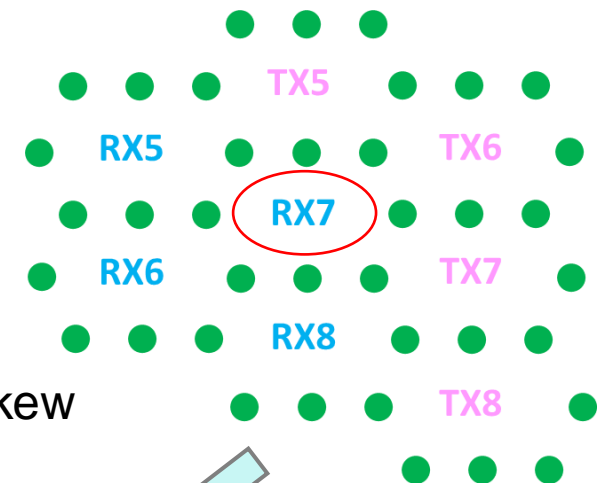

OSFP connector breakout is modeled on an “MCB” implementation

- Loss: ~1.3dB/in @53.125GHz
- Stripline routing, blind vias

## OSFP Pin Map

60	59	58	57	56	55	54	53	52	51	50	49	48	47	46	45	44	43	42	41	40	39	38	37	36	35	34	33	32	31
G	TX1	G	TX3	G	TX5	G	TX7	G	MGMT	VCC	VCC	MGMT	G	RX8	G	RX6	G	RX4	G	RX2	G								
G	TX2	G	TX4	G	TX6	G	TX8	G	MGMT	VCC	VCC	MGMT	G	RX7	G	RX5	G	RX3	G	RX1	G								
1	2	3	4	5	6	7	8	9	10	11	12	13	14	15	16	17	18	19	20	21	22	23	24	25	26	27	28	29	30

# CR Copper Cable Channels

- File naming convention: THRU Path

KR-CR\_CH[#]\_[TP0SideHostLoss]dBHost\_[Length]m26AWG\_[TP5SideHostLoss]dBHost\_THRU.s4p

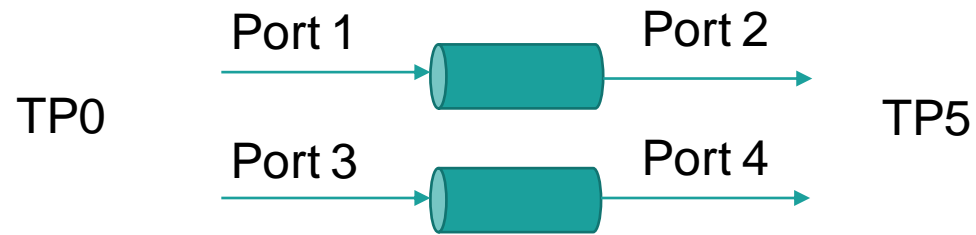

**All Models:**

- 50-ohm reference Z0
- DC-100GHz
- 10MHz steps

- File naming convention: CROSSTALK Path

KR-CR\_CH[#]\_[TP0SideHostLoss]dBHost\_[Length]m26AWG\_[TP5SideHostLoss]dBHost\_[Xtalk][#].s4p

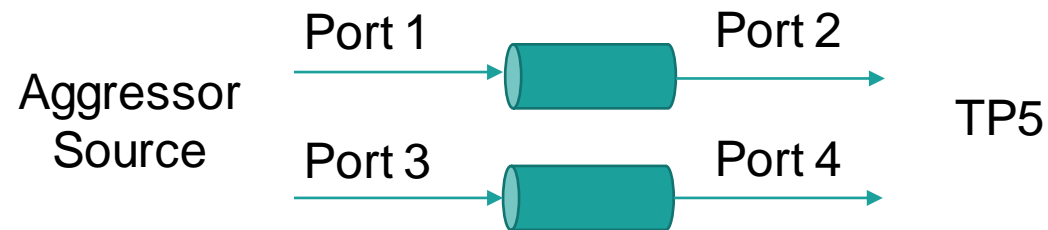



# CR Copper Cable Channel Model Nomenclature

## THRU PATH

- KR-CR\_CH01\_8dBHost\_1m26AWG\_8dBHost\_THRU.s4p ← “kocsis\_01\_3dj\_2305\_01”

## CROSSTALK PATH

- KR-CR\_CH01\_8dBHost\_1m26AWG\_8dBHost\_FEXT1.s4p
- KR-CR\_CH01\_8dBHost\_1m26AWG\_8dBHost\_FEXT1a.s4p ← Crosstalk modeled as shown on Slide 6  
FEXT1 duplicated for worst-case victim-aggressor mapping in analysis
- KR-CR\_CH01\_8dBHost\_1m26AWG\_8dBHost\_FEXT2.s4p
- KR-CR\_CH01\_8dBHost\_1m26AWG\_8dBHost\_FEXT3.s4p
- KR-CR\_CH01\_8dBHost\_1m26AWG\_8dBHost\_NEXT1.s4p
- KR-CR\_CH01\_8dBHost\_1m26AWG\_8dBHost\_NEXT2.s4p
- KR-CR\_CH01\_8dBHost\_1m26AWG\_8dBHost\_NEXT3.s4p
- KR-CR\_CH01\_8dBHost\_1m26AWG\_8dBHost\_NEXT4.s4p

**KR-CR\_CH01 Characteristics**

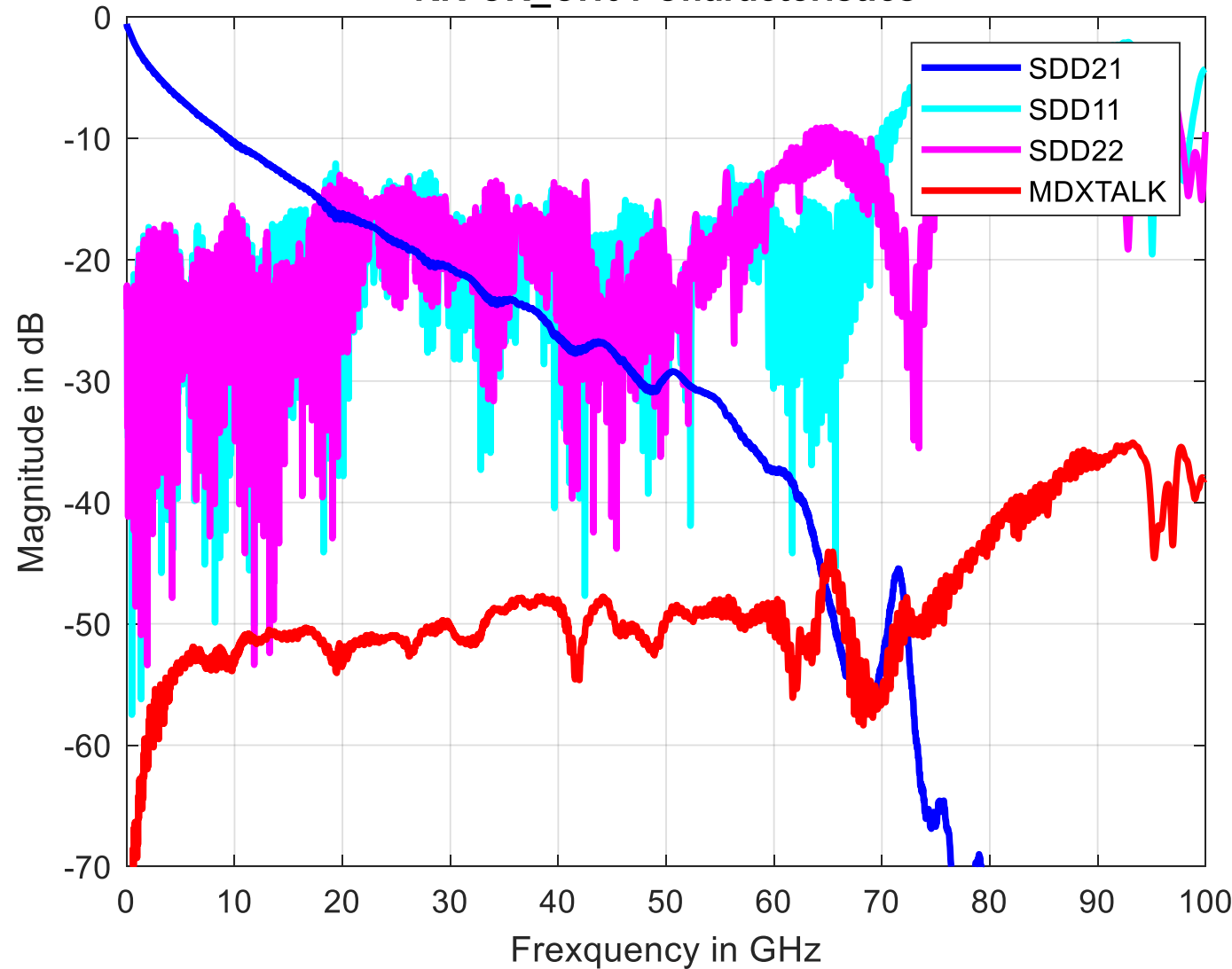

**CH01 Summary**

IL @53.125GHz	30.75 dB
RL (MAX DC-53.125GHz)	12.08 dB
ICR @53.125GHz	18.16 dB

**Plot notes:**

- 50-ohm reference Z0
- MDXTALK (4FEXT + 4NEXT)

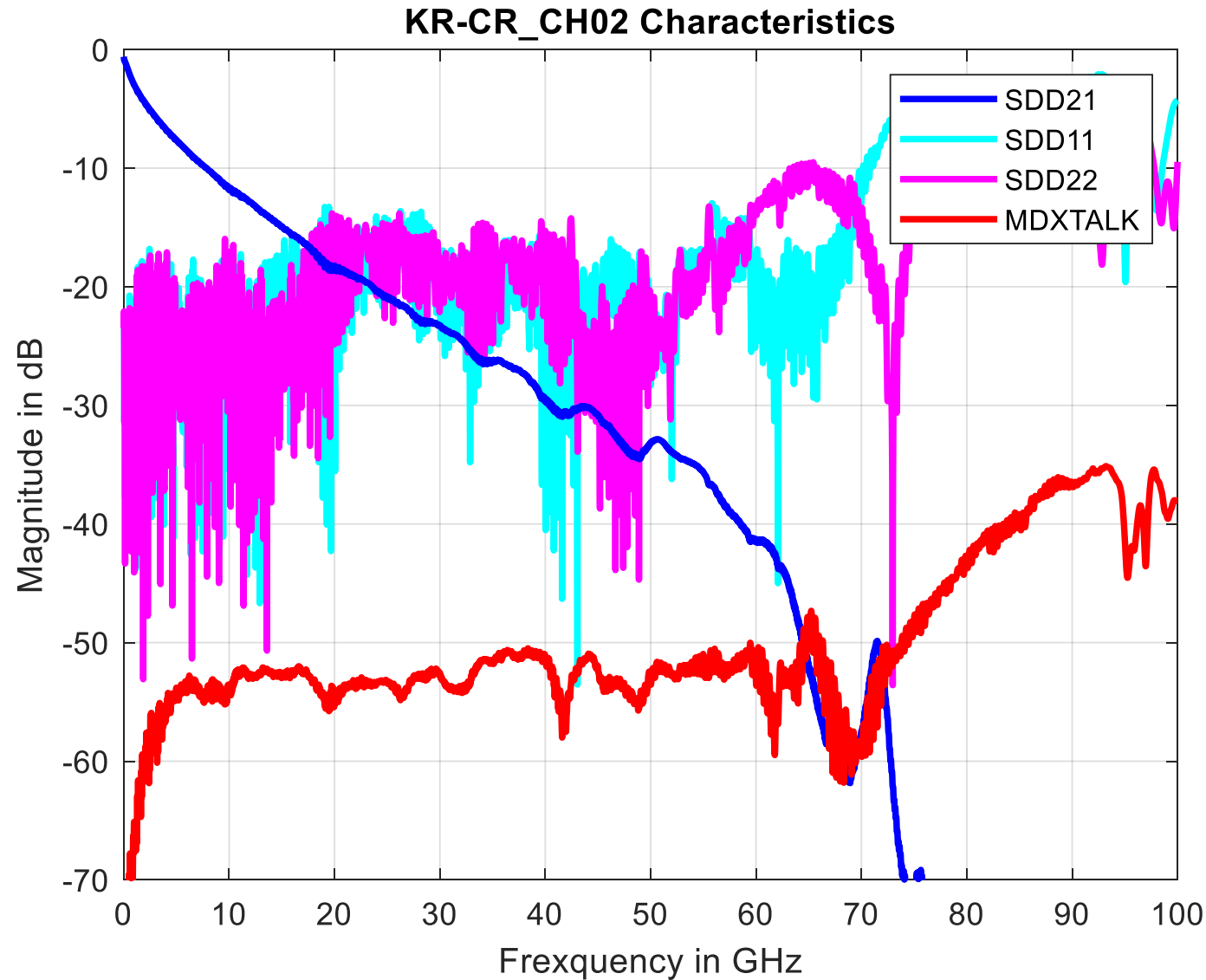

CH02 Summary	
IL @53.125GHz	34.51 dB
RL (MAX DC-53.125GHz)	13.27 dB
ICR @53.125GHz	17.49 dB

**Plot notes:**

- 50-ohm reference Z0
- MDXTALK (4FEXT + 4NEXT)

**KR-CR\_CH03 Characteristics**

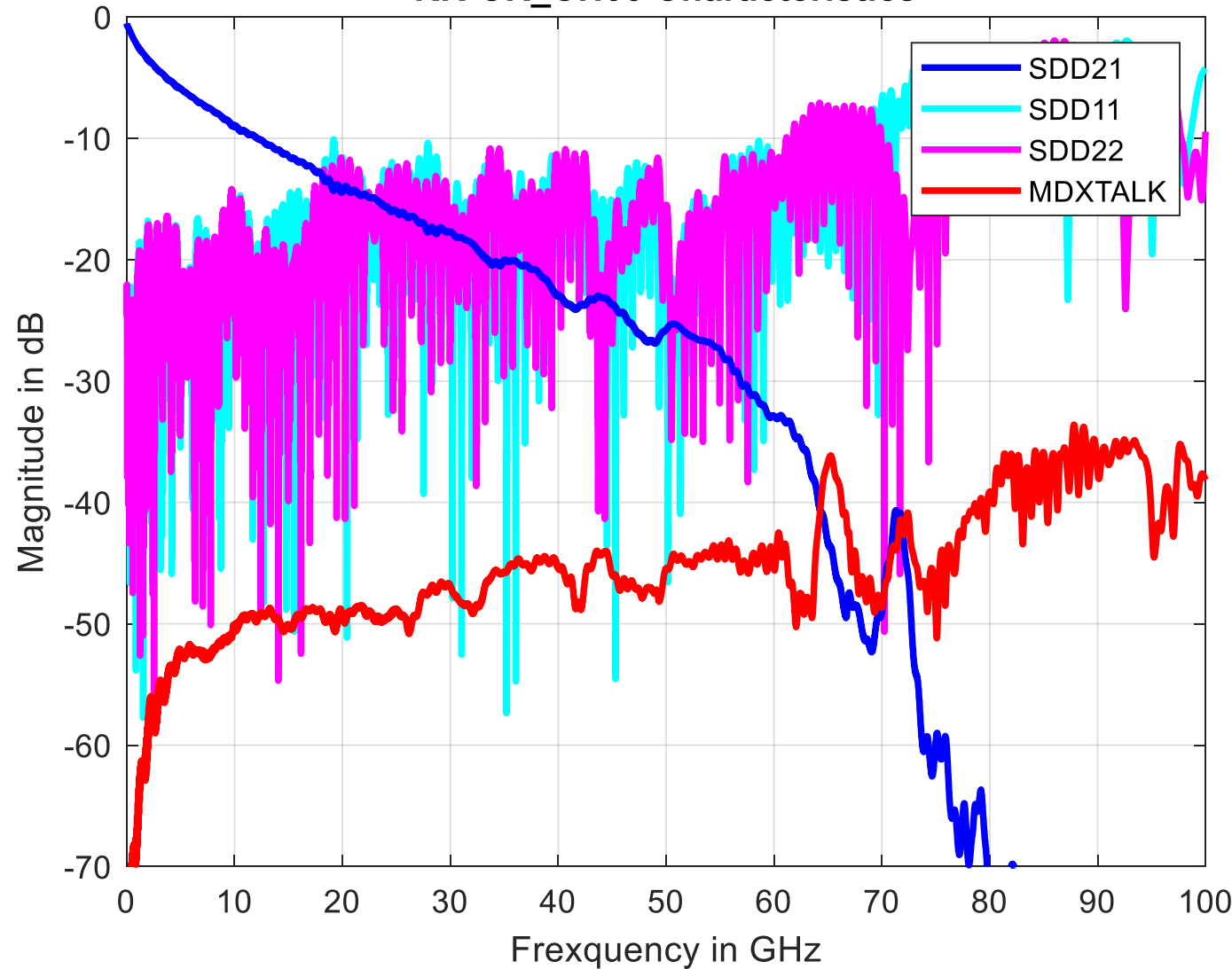

### CH03 Summary

IL @53.125GHz	26.65 dB
RL (MAX DC-53.125GHz)	10.08 dB
ICR @53.125GHz	17.90 dB

**Plot notes:**

- 50-ohm reference Z0
- MDXTALK (4FEXT + 4NEXT)

**KR-CR\_CH04 Characteristics**

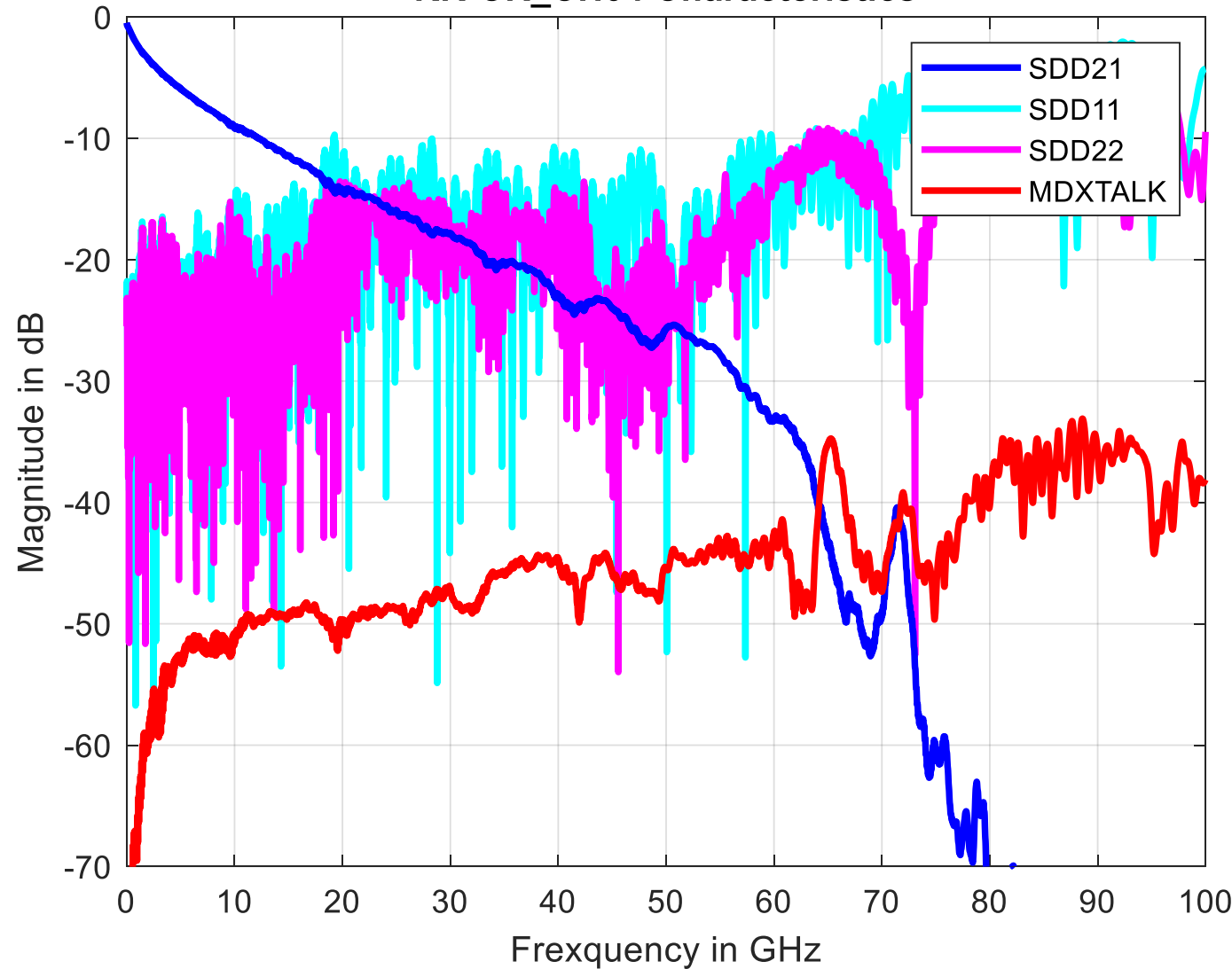

### CH04 Summary

IL @53.125GHz	26.74 dB
RL (MAX DC-53.125GHz)	9.70 dB
ICR @53.125GHz	17.43 dB

**Plot notes:**

- 50-ohm reference Z0
- MDXTALK (4FEXT + 4NEXT)

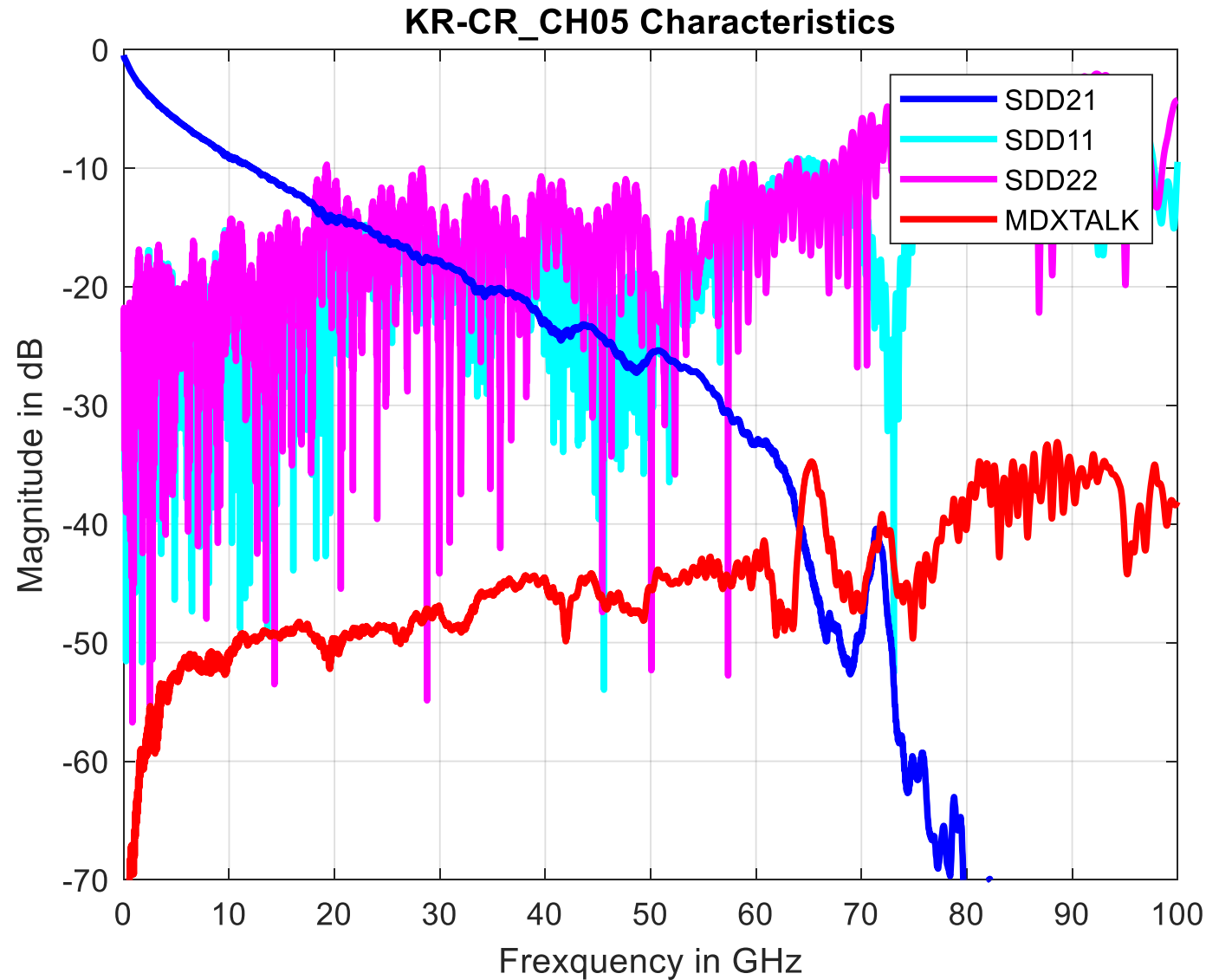

CH05 Summary	
IL @53.125GHz	26.74 dB
RL (MAX DC-53.125GHz)	9.70 dB
ICR @53.125GHz	17.43 dB

**Plot notes:**

- 50-ohm reference Z0
- MDXTALK (4FEXT + 4NEXT)

# COM Configuration (“Set 1”)

Per mellitz 3dj elec 04a 230504

Table 93A-1 parameters			
Parameter	Setting	Units	Information
f_b	106.25	GBd	
f_min	0.05	GHz	
Delta_f	0.01	GHz	
C_d	[0.4e-4 0.9e-4 1.1e-4 ;0.4e-4 0.9e-4 1.1e-4 ]	nF	[TX RX]
L_s	[0.13 0.15 0.14; 0.13 0.15 0.14 ]	nH	[TX RX]
C_b	[0.3e-4 0.3e-4 ]	nF	[TX RX]
z_p select	[ 2 ]		[test cases to run]
z_p (TX)	[6 31; 1 1; 1 1; 0.5 0.5]	mm	[test cases]
z_p (NEXT)	[8 29; 1 1; 1 1; 0.5 0.5]	mm	[test cases]
z_p (FEXT)	[6 31; 1 1; 1 1; 0.5 0.5]	mm	[test cases]
z_p (RX)	[8 29; 1 1; 1 1; 0.5 0.5]	mm	[test cases]
PKG_Tx_FFE_preset	0		
C_p	[0.5e-4 0.5e-4]	nF	[TX RX]
R_0	50	Ohm	
R_d	[ 45 45 ]	Ohm	[TX RX]
A_v	0.386	V	vp/vf=
A_fe	0.386	V	vp/vf=
A_ne	0.6	V	
L	4		
M	32		
filter and Eq			
f_r	0.58	*fb	
c(0)	0.55		min
c(-1)	[-0.4:0.02:0]		[min:step:max]
c(-2)	[0:0.02:0.1]		[min:step:max]
c(-3)	0		[min:step:max]
c(-4)	0		[min:step:max]
c(1)	[-0.2:0.05:0]		[min:step:max]
N_b	1	UI	
b_max(1)	0.75		As/dffe1
b_max(2..N_b)	0.15		As/dfe2..N_b
b_min(1)	0		As/dffe1
b_min(2..N_b)	-0.15		As/dfe2..N_b
g_DC	[-15:1:-3]	dB	[min:step:max]
f_z	25.16	GHz	
f_p1	40.00	GHz	
f_p2	56.00	GHz	
g_DC_HP	[-5:1:0]		[min:step:max]
f_HP_PZ	1.328125	GHz	
Butterworth	1	logical	include in fr
Raised_Cosine	0	logical	include in fr
RC_Start	5.31E+10	Hz	start freq for RCos
RC_end	6.16E+10	Hz	end freq for RCos

I/O control		
DIAGNOSTICS	1	logical
DISPLAY_WINDOW	0	logical
CSV_REPORT	1	logical
RESULT_DIR	.\results\CAKR_(date)\	
SAVE_FIGURES	0	logical
Port Order	[ 1 3 2 4 ]	
RUNTAG	KR_eval_	
COM_CONTRIBUTION	0	logical
Operational		
ERL Pass threshold	10	dB
COM Pass threshold	3	db
DER_0	1.00E-04	
T_r	4.00E-03	ns
FORCE_TR	1	logical
PMD_type	C2C	
EW	1	
TDR and ERL options		
TDR	1	logical
ERL	1	logical
ERL_ONLY	0	ns
TR_TDR	0.01	
N	1000	logical
TDR_Butterworth	1	
beta_x	0	
rho_x	0.618	
TDR_W_TXPKG	0	UI
N_bx	20	
fixture delay time	[ 0 0 ]	
Tukey_Window	1	
Noise, jitter		
sigma_RJ	0.01	UI
A_DD	0.02	V^2/GHz
eta_0	4.00E-09	dB
SNR_TX	33	
R_LM	0.95	
11-2022 BenArtsi pkg		
highlighted are under re-consideration		
Parameter	Setting	Units
MLSE	1	logical

Table 93A-3 parameters		
Parameter	Setting	Units
package_tl_gamma0_a1_a2	[0 0.0008455 0.000340225]	
package_tl_tau	0.00644805	ns/mm
package_Z_c	[92 92 ; 70 70; 80 80; 100 100]	Ohm
ICN parameters		
f_v	0.278	Fb
f_f	0.278	Fb
f_n	0.278	Fb
f_2	61.625	GHz
A_ft	0.450	V
A_nt	0.450	V
Floating Tap Control		
N_bg	0	0 1 2 or 3 groups
N_bf	3	taps per group
N_f	80	UI span for floating taps
bmaxg	0.2	max DFE value for floating taps
B_float_RSS_MAX	0.1	rss tail tap limit
N_tail_start	25	(UI) start of tail taps limit
Receiver testing		
RX_CALIBRATION	0	logical
Sigma BBN step	5.00E-03	V
Selelions (rectangle, gaussian,dual_rayleigh,triangle		
Histogram_Window_Weight	gaussian	selection
Qr	0.02	UI
Filter: Rx FFE		
ffe_pre_tap_len	6	UI
ffe_post_tap_len	60	UI
ffe_tap_step_size	0	
ffe_main_cursor_min	1	
ffe_pre_tap1_max	1	
ffe_post_tap1_max	1	
ffe_tapn_max	1	
ffe_backoff	0	

*Package length adjusted to maintain 40dB “die-to-die” in each analysis*

# COM Configuration (“Set 2”)

Per mellitz 3dj elec 04a 230504

Table 93A-1 parameters			
Parameter	Setting	Units	Information
f_b	106.25	GBd	
f_min	0.05	GHz	
Delta_f	0.01	GHz	
C_d	[0.4e-4 0.9e-4 1.1e-4 ; 0.4e-4 0.9e-4 1.1e-4 ]	nF	[TX RX]
L_s	[0.13 0.15 0.14; 0.13 0.15 0.14 ]	nH	[TX RX]
C_b	[0.3e-4 0.3e-4 ]	nF	[TX RX]
z_p select	[ 2 ]		[test cases to run]
z_p (TX)	[12 31; 1.8 1.8]	mm	[test cases]
z_p (NEXT)	[12 29; 1.8 1.8]	mm	[test cases]
z_p (FEXT)	[12 31; 1.8 1.8]	mm	[test cases]
z_p (RX)	[12 29; 1.8 1.8]	mm	[test cases]
PKG_TX_FFE_preset	0		
C_p	[0.4e-4 0.4e-4]	nF	[TX RX]
R_0	50	Ohm	
R_d	[46.25 46.25]	Ohm	[TX RX]
A_v	0.413	V	vp/vf=
A_fe	0.413	V	vp/vf=
A_ne	0.608	V	
AC_CM_RMS	0	V	[test cases]
L	4		
M	32		
filter and Eq			
f_r	0.5	*fb	
c(0)	0.54		min
c(-1)	[-0.4:0.02:0]		[min:step:max]
c(-2)	[0:0.02:0.16]		[min:step:max]
c(-3)	[-0.1:0.02:0]		[min:step:max]
c(-4)	[0:0.02:0.1]		[min:step:max]
c(-5)	0		[min:step:max]
c(-6)	0		[min:step:max]
c(1)	[-0.2:0.02:0]		[min:step:max]
N_b	1	UI	
b_max(1)	0.85		As/dfe1
b_max(2..N_b)	[0.3 0.2*ones(1,22)]		As/dfe2..N_b
b_min(1)	0		As/dfe1
b_min(2..N_b)	[-0.3 -0.2*ones(1,22)]		As/dfe2..N_b
g_DC	[-20:1:0]	dB	[min:step:max]
f_z	42.50	GHz	
f_p1	42.50	GHz	
f_p2	106.25	GHz	
g_DC_HP	[-6:1:0]		[min:step:max]
f_HP_PZ	0.6640625	GHz	
Butterworth	1	logical	include in fr
Raised_Cosine	0	logical	include in fr
RC_Start	5.31E+10	Hz	start freq for RCos
RC_end	5.31E+10	Hz	end freq for RCos

I/O control		
DIAGNOSTICS	1	logical
DISPLAY_WINDOW	1	logical
CSV_REPORT	0	logical
RESULT_DIR	.\results\CAKR_{date}\	
SAVE_FIGURES	0	logical
Port Order	[ 1 3 2 4 ]	
RUNTAG	KR_eval_	
COM_CONTRIBUTION	0	logical
Operational		
ERL Pass threshold	10	dB
COM Pass threshold	3	db
DER_0	1.00E-04	
T_r	4.00E-03	ns
FORCE_TR	1	logical
Local Search	2	
BREAD_CRUMBS	1	logical
PLOT_CM	0	
TDR and ERL options		
TDR	1	logical
ERL_ONLY	1	logical
ERL_ONLY	0	ns
TR_TDR	0.01	
N	3500	logical
beta_x	0	
rho_x	0.618	
TDR_W_TXPKG	0	
N_bx	21	UI
fixture delay time	[ 0 0 ]	
Tukey_Window	1	
Noise, jitter		
sigma_RJ	0.01	UI
A_DD	0.02	UI
eta_0	5.00E-09	V^2/GHz
SNR_TX	33	dB
R_LM	0.95	
11-2022 BenArtsi pkg		
highlighted are under re-consideration		
Parameter	Setting	Units
MLSE	1	logical

Table 93A-3 parameters		
Parameter	Setting	Units
package_tl_gamma0_a1_a2	[0.0005 0.00089 0.0002]	
package_tl_tau	0.006141	ns/mm
package_Z_c	[87.5 87.5 ; 92.5 92.5]	Ohm
ICN parameters		
f_v	0.528	Fb
f_f	0.528	Fb
f_n	0.528	Fb
f_2	80.000	GHz
A_ft	0.600	V
A_nt	0.600	V
Floating Tap Control		
N_bg	4	0 1 2 or 3 groups
N_bf	5	taps per group
N_f	60	UI span for floating taps
bmaxg	0.05	max DFE value for floating taps
B_float_RSS_MAX	0.02	rss tail tap limit
N_tail_start	50	(UI) start of tail taps limit
Receiver testing		
RX_CALIBRATION	0	logical
Sigma BBN step	5.00E-03	V
Seletions (rectangle, gaussian,dual_rayleigh,triangle		
Histogram_Window_Weight	gaussian	selection
Qr	0.02	UI
Filter: Rx FFE		
ffe_pre_tap_len	6	UI
ffe_post_tap_len	24	UI
ffe_tap_step_size	0	
ffe_main_cursor_min	0.7	
ffe_pre_tap1_max	0.7	
ffe_post_tap1_max	0.7	
ffe_tapn_max	0.7	
ffe_backoff	0	

*Package length adjusted to maintain 40dB “die-to-die” in each analysis*



# CR Copper Cable Channel Configurations

Configuration	TP0-TP5 Loss (dB @53.125GHz)	Package Length ("Set 1", Tx/Rx)	Package Length ("Set 2", Tx/Rx)	Die-Die Loss (dB @53.125GHz)
1	30.75	23mm / 21mm	26mm / 24mm	41.72 / 39.91
2	34.51	14mm / 12mm	16mm / 14mm	41.67 / 40.71
3	26.65	32mm / 30mm	37mm / 35mm	41.38 / 39.17
4	26.74	6mm / 56mm	6mm / 66mm	41.33 / 39.22
5	26.74	32mm / 30mm	37mm / 35mm	41.37 / 39.13

- Package Model for "Set 1" is ~0.18dB/mm @53.125GHz
- Package Model for "Set 2" is ~0.21dB/mm @53.125GHz

# CR Copper Cable Channel COM Results

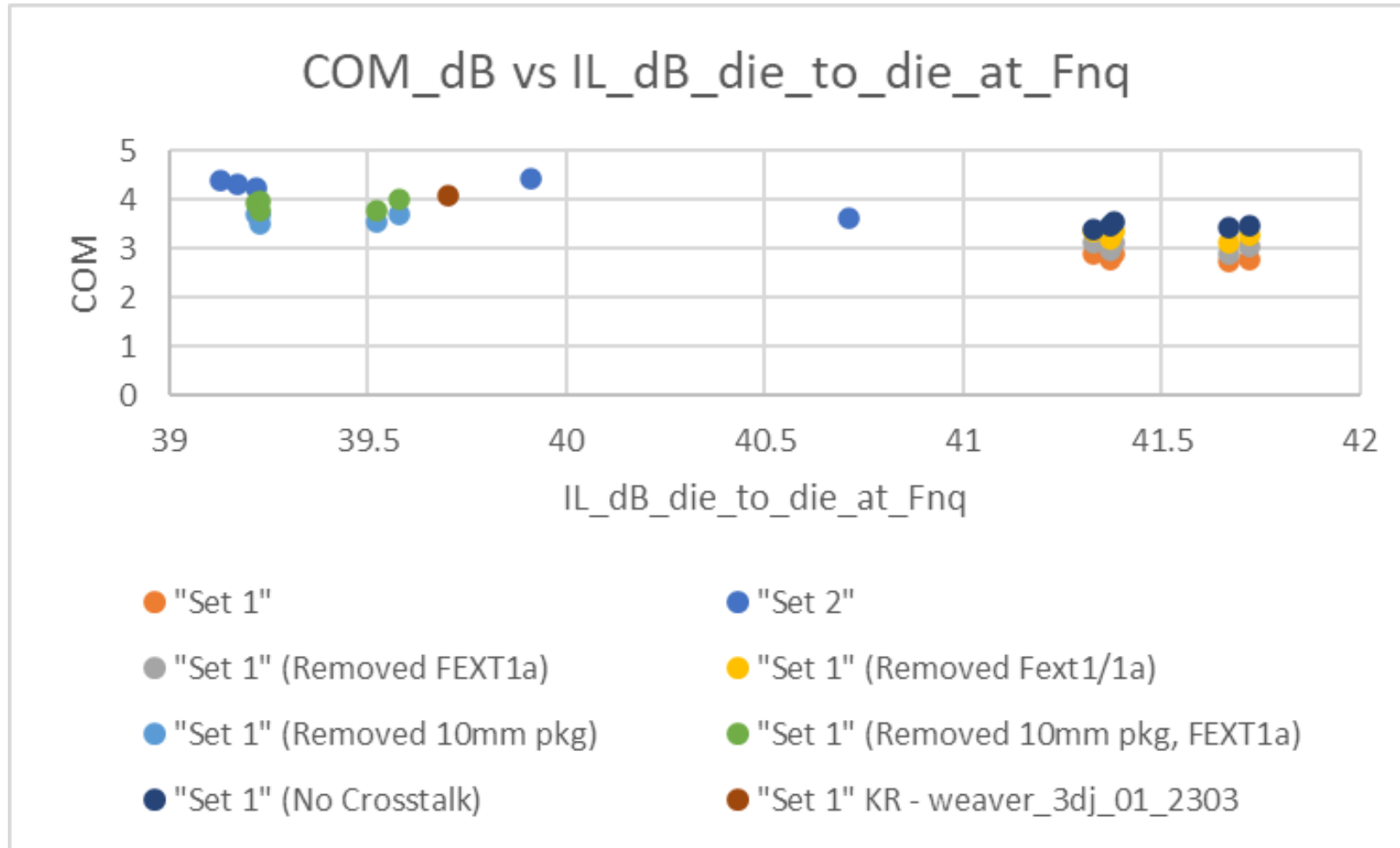

- Solution space exists, but more work is needed to refine COM parameters and budget allocation for a baseline proposal

- Results presented for new copper cable channel models
  - Informative only, not a proposal for a baseline
- Demonstrated compatibility of the copper cable objective with the anticipated “KR” objective and supporting analysis
  - [mellitz\\_3dj\\_elec\\_04a\\_230504](#)
- CR baseline should consider multiple channel configurations
  - Symmetric and Asymmetric links
  - Balance Package and Host
- More work is needed to refine COM parameters and budget allocation for a baseline proposal
  - Specific attention needed on the “short” Package, “short” Host case

A background graphic consisting of a network of interconnected nodes and lines, rendered in shades of blue and white, set against a dark teal gradient background.

# Thank You

**Amphenol**  
COMMUNICATIONS SOLUTIONS