802.3dj - CR

Considerations for Insertion Loss Budget Baseline

Chris DiMinico
PHY-SI LLC/SenTekse LLC
cdiminico@ieee.org

Contributors

- Mike Li - Intel
- Howard Heck - Intel
- Kent C Lusted - Intel
- Samuel Kocsis - Amphenol
- Nathan Tracy - TE Connectivity
- Megha Shanbhag - TE Connectivity
- Jim Weaver - Arista
- Jason Chan - Arista
- Piers Dawe - Nvidia
- Adam Healey - Broadcom
- Greg Barsky - Broadcom
- Karlheinz Muth - Broadcom

Supporters

- Leesa Noujeim - Google
- Hong Anh - Google
- Mike Li - Intel
- Howard Heck - Intel
- Kent C Lusted - Intel
- Samuel Kocsis - Amphenol
- Nathan Tracy - TE Connectivity
- Megha Shanbhag - TE Connectivity
- Jim Weaver - Arista
- Jason Chan - Arista
- Piers Dawe - Nvidia
- Adam Healey - Broadcom
- Greg Barsky - Broadcom
- Karlheinz Muth - Broadcom

Introduction

- 802.3 CR channels are depicted informatively and analyzed in COM with Host PCBs that have the same IL on both ends (symmetrical).
- As device packages and other circuit element losses take up a greater portion of the overall budget, being able to reallocate losses in the channel becomes highly valuable.
- An enhanced concept is proposed enabling loss reallocation as well as enabling longer cable assemblies.
- The idea of enabling multiple copper cable assemblies with different maximum loss is not new and was done in Clause 110, where the channel variable was different FECs - see supplemental.
- This concept can be implemented using planned tools (COM)

References

- July 2023 "A Possible Path to More Flexible Architectures and Longer Reach Passive Copper Cables slides:
https://www.ieee802.org/3/dj/public/23_07/tracy_3dj_01a_2307.pdf
- May 2021 "Improving the CR Loss Budget
https://ieee802.org/3/ck/public/adhoc/apr28_21/dawe_3ck_adhoc_01_042821.pdf
- Models posted with asymmetric use cases;
 - https://www.ieee802.org/3/dj/public/tools/CR/kocsis_3dj_02_2305.zip
- May 2022 "802.3df considerations for test fixtures"
 - https://www.ieee802.org/3/df/public/adhoc/electrical/22_0502/diminico_3df_01_220502.pdf

Proposed Solution

- **Considerations for Insertion Loss Budget Baseline - symmetrical and asymmetrical**
 - **Host options (loss) -**
 - > **Host Nominal (HN),**
 - > **Host High, (HH),**
 - > **and Host Low (HL),**
 - > **or some other designation.**
 - **Associated cable assemblies -**
 - > **For PMD type 200GBASE-CR1 >> CA-200G-A,B,C - 1 lane**
 - > **For PMD type 400GBASE-CR2 >> CA-400G-A,B,C - 2 lane**
 - > **For PMD type 800GBASE-CR4 >> CA-800G-A,B,C - 4 lane**
 - > **For PMD type 1.6TBASE-CR8 >> CA-1.6T-A,B,C - 8 lane**
 - > **or some other designation.**
 - **The specifications for CA-A are identical except the number of lanes.**
 - **The specifications for CA-B are identical except the number of lanes.**
 - **The specifications for CA-C are identical except the number of lanes.**

Already Adopted

- Adopted: die-to-die insertion loss

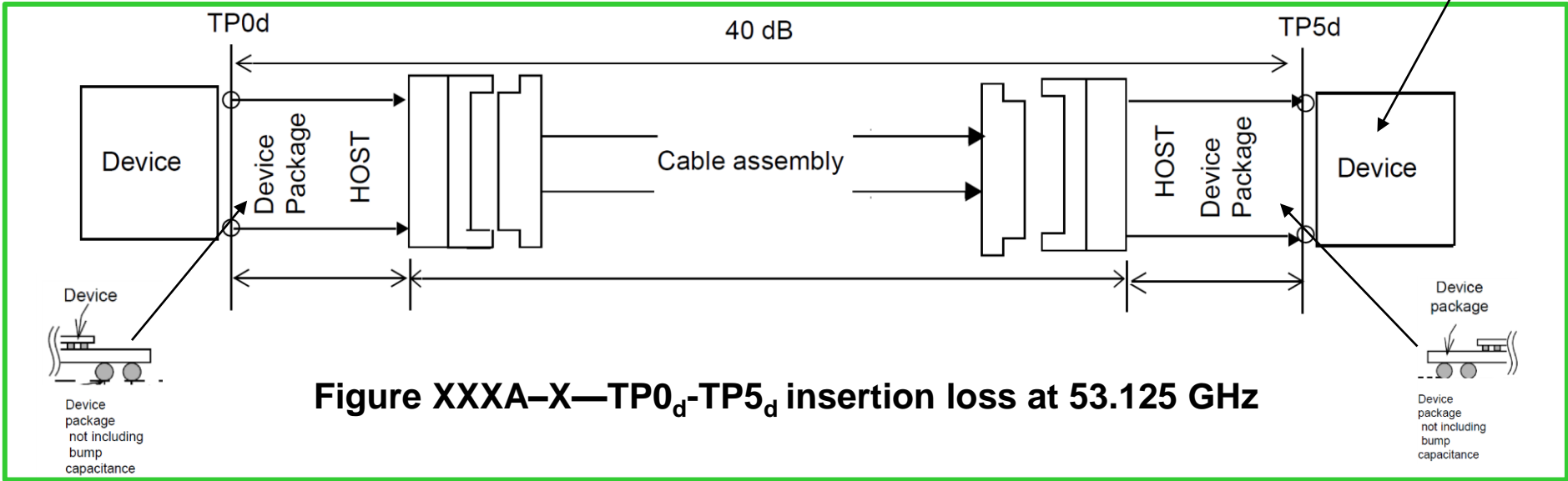
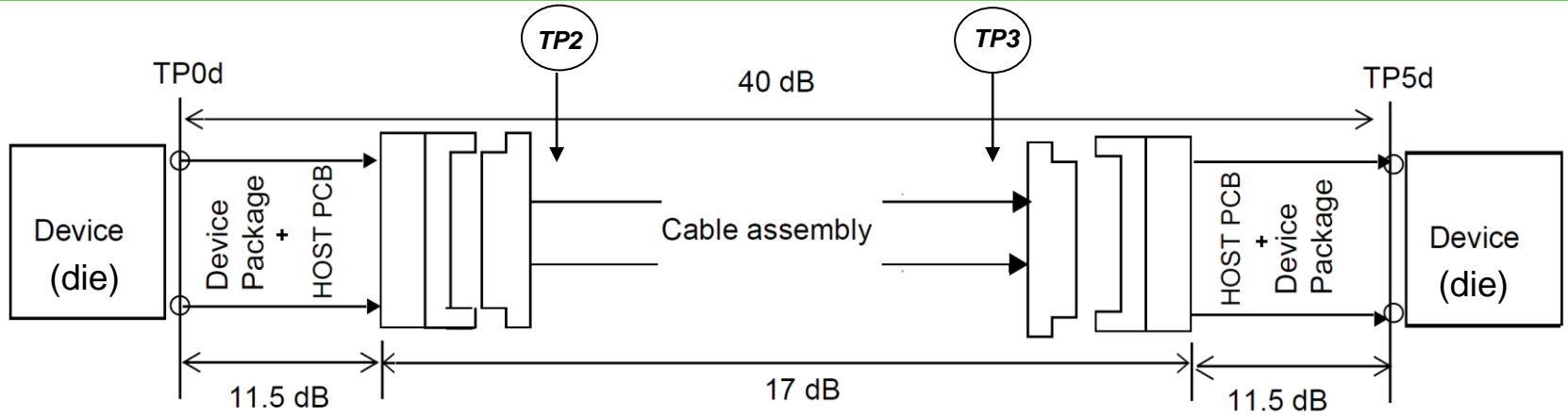

Figure XXXA-X—TP0_d-TP5_d insertion loss at 53.125 GHz

https://www.ieee802.org/3/dj/public/23_07/minutes_3dj_2307_unapproved.pdf

Motion #7	Move to adopt a die-to-die insertion loss ≤ 40 dB at 53.125 GHz for 200GBASE-CR1, 400GBASE-CR2, 800GBASE-CR4 and 1.6TBASE-CR8 PHYs
Technical ($\geq 75\%$)	
Moved by	Mike Li
Second by	Nathan Tracy
Results 802.3 (y/n/a)	passed by unanimous consent. 9:25 a.m.

Symmetrical Link - Informative Annex



$$TP0_d - TP5_d = 11.5 + 17 + 11.5 = 40 \text{ dB}$$

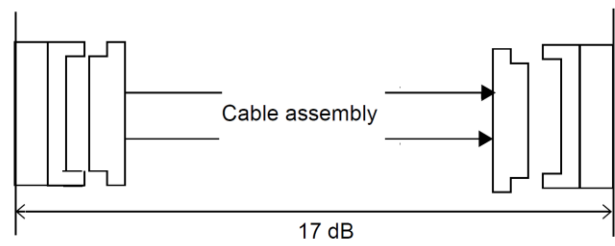
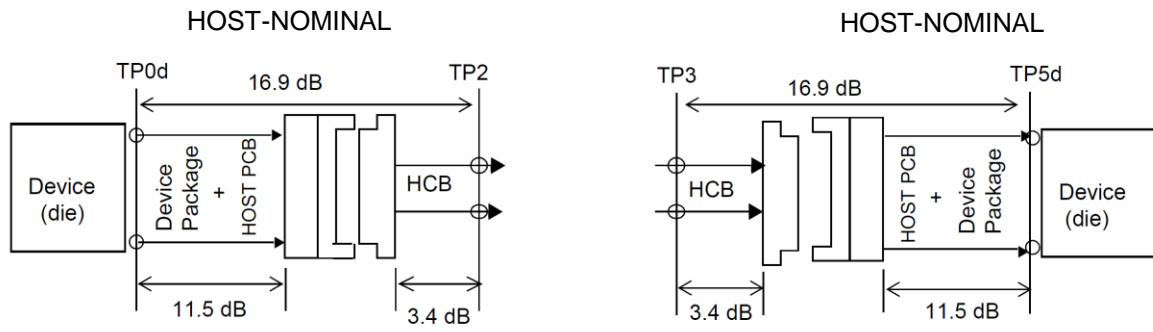

$$MAX \text{ IL} = 40 - (11.5 + 11.5) = 17 \text{ dB}$$

Asymmetrical Links - Informative Annex

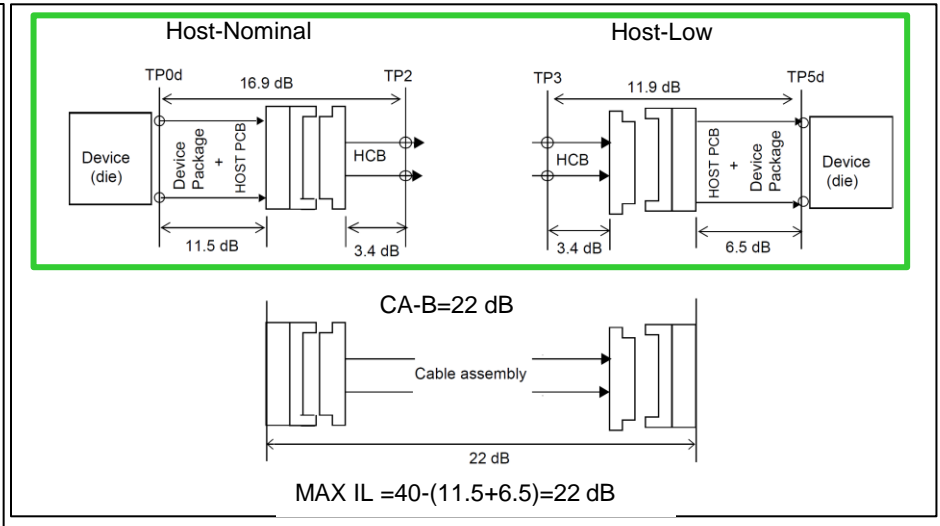
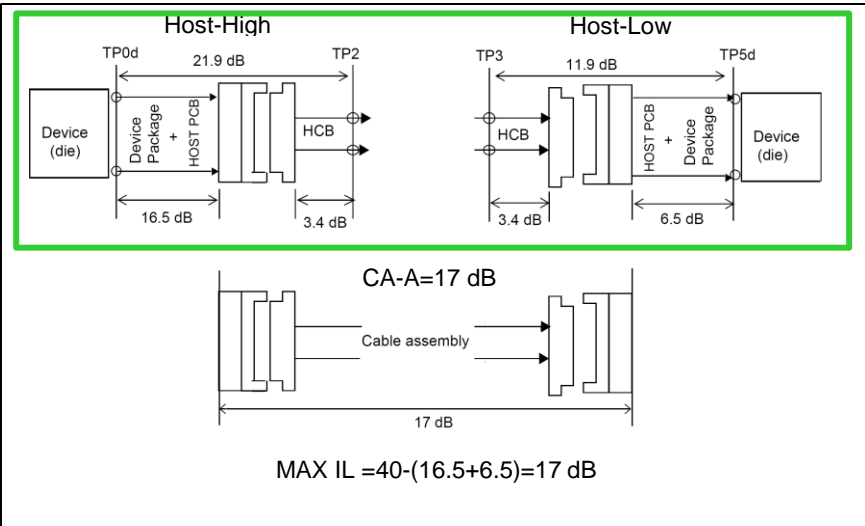

Link Configurations IL (TX to RX)

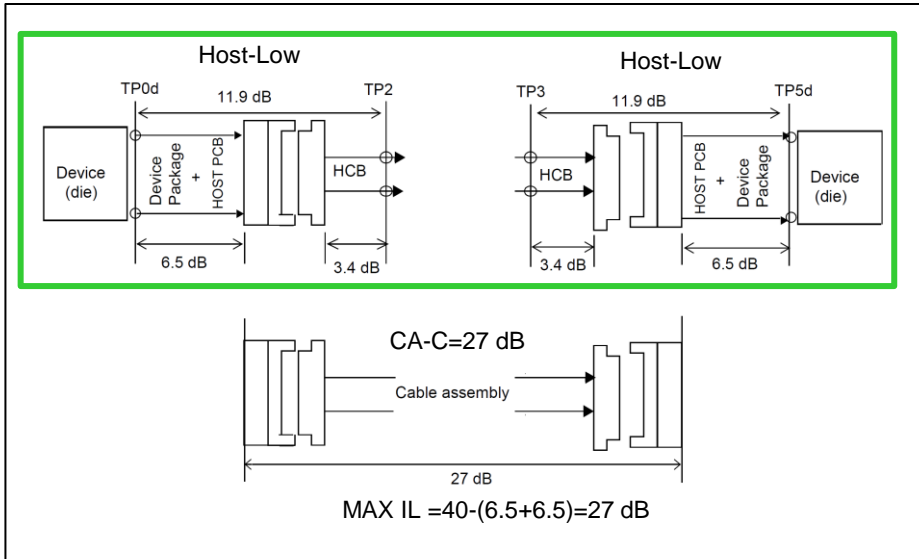

	Host-Low	Host-Nominal	Host-High
Host -Low	CA-A,B,C	CA-A,B	CA-A
Host-Nominal	CA-A,B	CA-A	not supported
Host-High	CA-A	not Supported	not supported

	Device Package + Host PCB		Cable + 2xconnectors	
Host-Low	6.5 dB		CA-A	17 dB
Host-Nominal	11.5 dB		CA-B	22 dB
Host-High	16.5 dB		CA-C	27 dB

COM and Host Loss

- COM analysis similar to 802.3ck with addition of Host Loss options in COM setup file (Host-Low, Host-Nominal, or Host-High)
- COM analysis includes cases in the following table;
 - CA-A cable assemblies shall pass six Host combinations
 - CA-B cable assemblies shall pass three Host combinations
 - CA-C cable assembly shall pass one Host combination

Link Configurations IL (TX to RX)

	Host-Low	Host-Nominal	Host-High
Host -Low	CA-A,B,C	CA-A,B	CA-A
Host-Nominal	CA-A,B	CA-A	not supported
Host-High	CA-A	not Supported	not supported

- CA-A/B/C shall pass respective cable assembly specifications

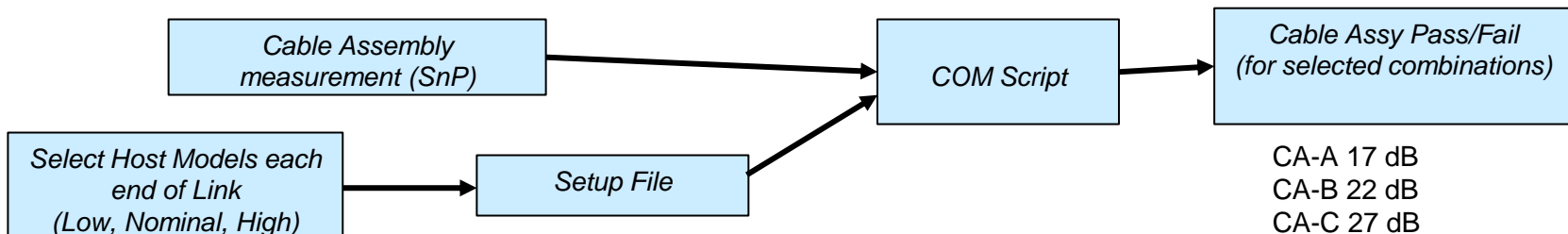

Summary

- Insertion loss baseline for symmetrical and asymmetrical links.
- The 40 dB die-to-die loss budget allocated to enable a wider variety of host losses and cable assembly losses (reach).

Supplemental

Clause 110. type 25GBASE-CR and 25GBASE-CR-S

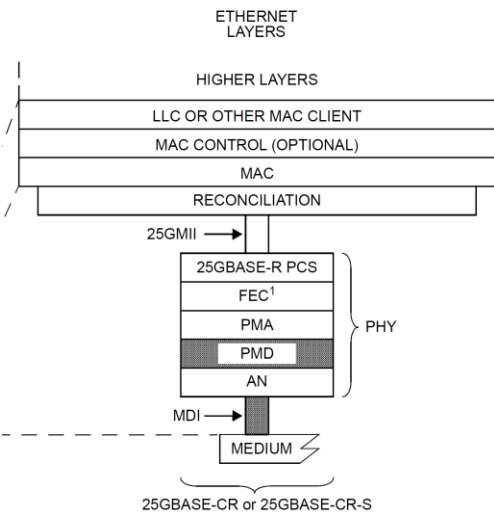

A 25GBASE-CR PHY operates over cable assemblies of types CA-25G-N, CA-25G-S and CA-25G-L (see 110.10). A 25GBASE-CR-S PHY operates over cable assemblies of types CA-25G-N and CA-25G-S. A 25GBASE-CR-S PHY interoperates with a 25GBASE-CR PHY. Table 110–2 summarizes the cable assembly types supported by each of the PHY types.

Table 110–2—Cable assembly types supported by each PHY type

PHY type	CA-25G-N	CA-25G-S	CA-25G-L
25GBASE-CR	Yes	Yes	Yes
25GBASE-CR-S	Yes	Yes	No

Cable assembly type	Length ^a	FEC modes supported ^b
CA-25G-L	5 m	RS-FEC
CA-25G-S	3 m	RS-FEC BASE-R FEC
		RS-FEC BASE-R FEC
CA-25G-N	3 m	no FEC

^a Indicates the achievable length of compliant cable assemblies. It may be possible to construct compliant cable assemblies longer than indicated. Length of the cable assembly does not imply compliance to specifications.
^b FEC mode is selected through Auto-Negotiation (Clause 73). See 110.6.

Source: IEEE Std 802.3-2022, IEEE Standard for Ethernet

Proposed 200GbE/400GbE Architecture

- How various FEC schemes fit into the architecture
- FECs might or might not be reused across schemes

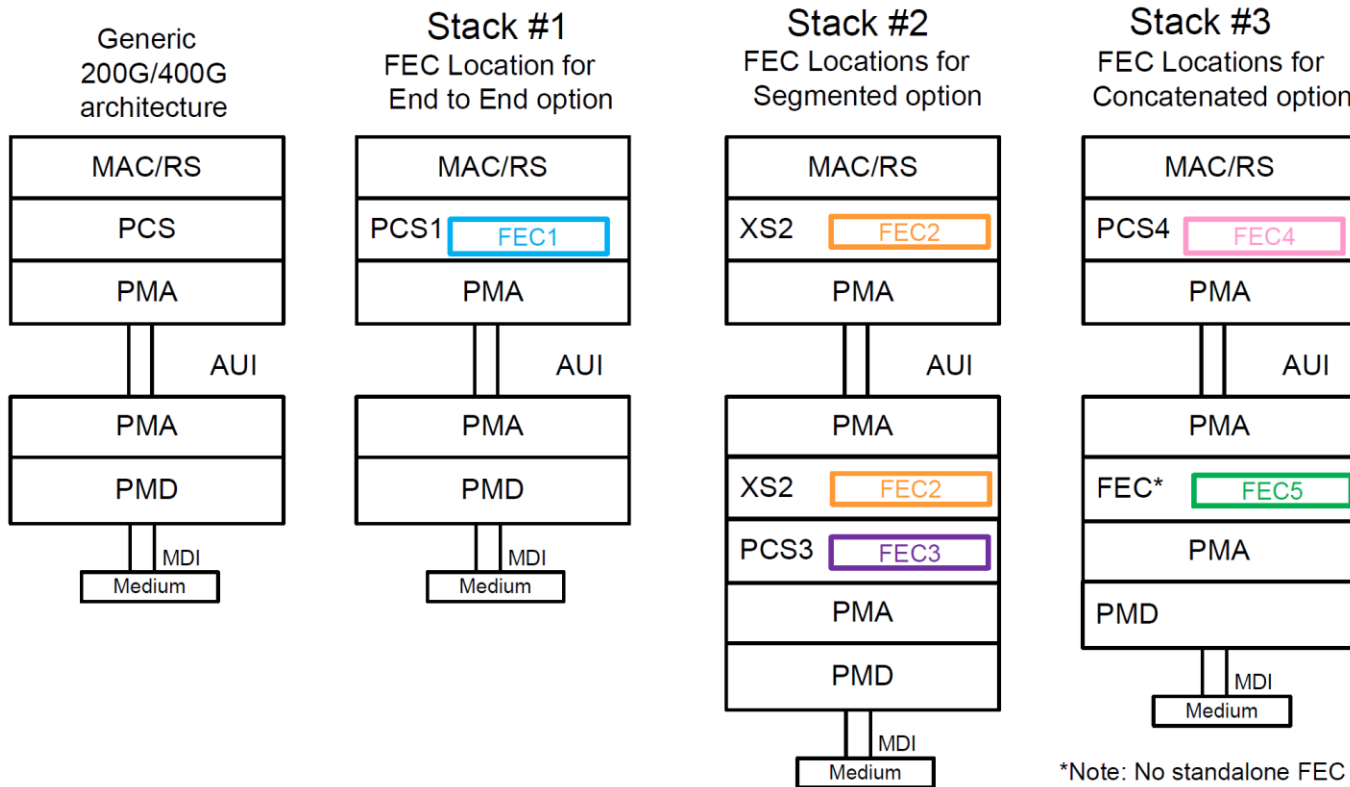
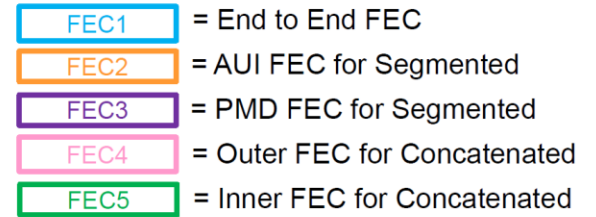

*Note: No standalone FEC sublayer in 802.3bs