

212.5 Gbps-PAM4 Chip-to-Module Link Simulation and Analysis with a “Universal Port” Channel: Design C

Mike Li, Jenny Jiang, Hsinho Wu, Masashi Shimanouchi, Ilia Radashkevich, Itamar Levin, Ariel Cohen (Intel)
Karan Jumani, Sina Bardikalaie, Vivek Shah, Scott Sommers (Molex)

Sept., 2023

Background and Introduction (I)

- An important and common Chip-to-Module (C2M) Channel is the so-called “Universal Port” C2M, as shown in the following diagram:

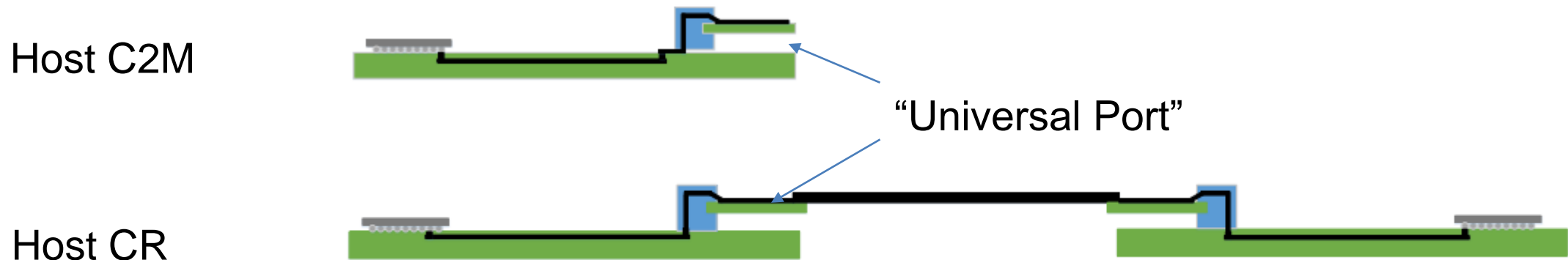

- We have created a C2M channel Design C to support “Universal Port”.

Background and Introduction (II)

- We leveraged our established/validated C2M simulation/modeling tool-flow-methodology (TFM) (e.g., [1], [2]), and updated reference package ([3]), to provide link simulation and analysis with this newly created C2M channel Design C.

Preliminary 212.5 Gbps PAM4 COM Analysis

for C2M Channel TP1a Test

- Based on 802.3ck chip-to-module COM with the following changes
 - TP1a COM Test Configuration:
 - Proposed reference TX
 - RLM = 0.95, SNR_{TX}=33dB, BUJ = 0.02UI_{pk}, RJ = 0.01UI_{RMS}
 - 20%-80% Rise/Fall Time (T_r): 4.0ps
 - TX FIR: 4-pre, 1-post
 - TX Die: No change (see [1],[2])
 - Termination impedance (R_d): 46.25 ohms
 - TX Package:
 - » $Z_p = 33\text{mm}$, $Z_{p2} = 1.8\text{mm}$
 - » γ_0 , a_2 , and C_p see [3]
 - TP1a Reference Receiver (Scope)
 - Based on scaled 802.3ck CR/C2M reference RX with DFE (8 fixed, 6 groups of 3 consecutive floating taps up to 60 UI), and Input Referred Noise = 5×10^{-9} V²/GHz
 - Termination impedance (R_d): 46.25 ohms
 - Measurement Window: +/-50mUI
 - DER: 10^{-6} , 10^{-5} , and 10^{-4}

Preliminary 212.5 Gbps PAM4 COM Analysis (cont.)

for C2M Channel TP1a Test

- Preliminary COM analysis results

DER =10^{-6}	Channel	EH	VEC	COM
	CH19	7.88 mV	12.64 dB	2.31 dB

DER =10^{-5}	Channel	EH	VEC	COM
	CH19	10.73 mV	9.96 dB	3.32 dB

DER =10^{-4}	Channel	EH	VEC	COM
	CH19	14.02 mV	7.64 dB	4.66 dB

Proposed COM Configuration

Table 93A-1 parameters			
Parameter	Setting	Units	Information
f_b	106.25	GBd	
f_min	0.05	GHz	
Delta_f	0.01	GHz	
C_d	[0.4e-4 0.9e-4 1.1e-4 ; 0 0 0]	nF	[TX RX]
L_s	[.13 .15 .14; 0 0 0]	nH	[TX RX]
C_b	[0.3e-4, 0e-4]	nF	[TX RX]
z_p select	[2]		[test cases to run]
z_p (TX)	[15 33; 1.8 1.8]	mm	[test cases]
z_p (NEXT)	[0 0 ; 0 0]	mm	[test cases]
z_p (FEXT)	[15 33; 1.8 1.8]	mm	[test cases]
z_p (RX)	[0 0 ; 0 0]	mm	[test cases]
C_p	[0.4e-4 0e-4]	nF	[TX RX]
R_0	50	Ohm	
R_d	[46.25 46.25]	Ohm	[TX RX]
A_v	0.413	V	vp/vf=.694
A_fe	0.413	V	vp/vf=.694
A_ne	0.489	V	
L	4		
M	32	Samp/UI	
samples_for_C2M	100	Samp/UI	
T_O	50	mUI	
AC_CM_RMS	0	V	[test cases]
filter and Eq			
f_r	0.5	*fb	
c(0)	0.54		min
c(-1)	[-0.4;0.02;0]		[min:step:max]
c(-2)	[0;0.02;0.16]		[min:step:max]
c(-3)	[-0.1;0.02; 0]		[min:step:max]
c(-4)	[0;0.02;0.1]		
c(1)	[-0.1;0.02;0]		[min:step:max]
N_b	8	UI	
b_max(1)	0.5		As/dfe1
b_max(2..N_b)	[0.3 0.2*ones(1,6)]		As/dfe2..N_b
b_min(1)	0		As/dfe1
b_min(2..N_b)	[-0.3 -0.2*ones(1,6)]		As/dfe2..N_b
g_DC	[-20;1;-0]	dB	[min:step:max]
f_z	39.1334731	GHz	
f_p1	59.4511386	GHz	
f_p2	112	GHz	
g_DC_HP	[-6;1;-0]		[min:step:max]
f_HP_P2	1.4	GHz	
G_Qual	[]	dB	ranges
G2_Qual	[]	dB	ranges
GDC_Min	0	dB	0 disables check. maybe different for each interface.

I/O control		
DIAGNOSTICS	1	logical
DISPLAY_WINDOW	1	logical
CSV_REPORT	1	logical
RESULT_DIR	\\results\100GEL_C2 M_host_{date}	
SAVE_FIGURES	0	logical
Port Order	[1 3 2 4]	
RUNTAG	C2M_eval_	
COM CONTRIBUTION	0	logical
Local Search	2	
Operational		
VEC Pass threshold	12	db
EH_min	8	mV
ERL Pass threshold	7.3	dB
Min_VEO_Test	0	mV
DER_0	1.00E-06	
T_r	0.004	ns
FORCE_TR	1	5
PMD_type	C2M	
BREAD_CRUMBS	0	logical
SAVE_CONFIG2MAT	1	logical
PLOT_CM	0	logical
TDR and ERL options		
TDR	1	logical
ERL	0	logical
ERL_ONLY	0	logical
TR_TDR	0.01	ns
N	800	
beta_x	0	
rho_x	0.618	
fixture delay time	[0 0.2e-9]	[port1 port2]
TDR_W_TXPKG	1	
N_bx	20	UI
Tukey_Window	1	
Receiver testing		
RX_CALIBRATION	0	logical
Sigma BBN step	5.00E-03	V
Noise_jitter		
sigma_RJ	0.01	UI
A_DD	0.02	UI
eta_0	5.00E-09	V^2/GHz
SNR_TX	33	dB
R_LM	0.95	

Table 93A-3 parameters		
Parameter	Setting	Units
package_tl_gamma0_a1_a2	[0.0005 0.00089 0.0002]	
package_tl_tau	0.006141	ns/mm
package_Z_c	[87.5 87.5 ; 92.5 92.5]	Ohm
ICN & FOM_ILD parameters		
f_v	0.528	*Fb
f_f	0.528	GHz f_r specified in first column
f_n	0.528	GHz
f_2	40	GHz
A_ft	0.600	V
A_nt	0.600	V
Histogram_Window_Weight		
sigma_r	Gaussian	gaussian, triangle, rectangle
	0.02	sigma in UI fo or gaus.. Wind
Table 92-12 parameters		
Parameter Setting		
board_tl_gamma0_a1_a2	[0 3.8206e-04 9.5909e-05]	
board_tl_tau	0.00579	ns/mm
board_Z_c	100	Ohm
z_bp (TX)	407	mm
z_bp (NEXT)	407	mm
z_bp (FEXT)	407	mm
z_bp (RX)	407	mm
C_0	0	nF
C_1	0	nF
include PCB	0	logical

Floating Tap Control		
N_bg	6	0 1 2 or 3 groups
N_bf	3	taps per group
N_f	60	UI span for floating taps
bmaxg	0.2	max DFE value for floating taps

different for each test fixture

updated for D3.1

Notes:

- COM v4.0 was used in this study.

Preliminary 212.5Gbps PAM4 COM Analysis (CH19/Design C)

TP1a

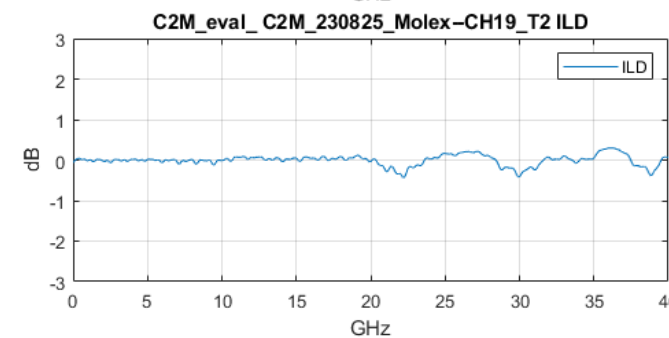
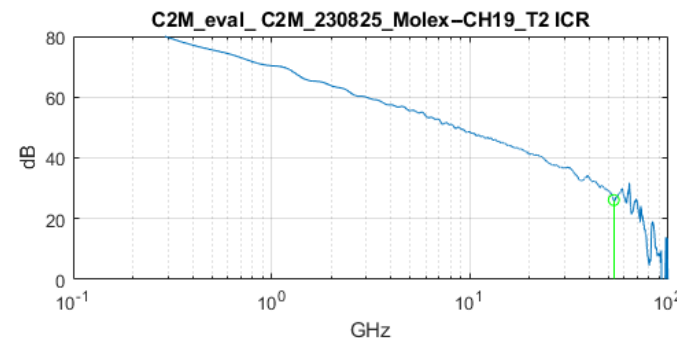
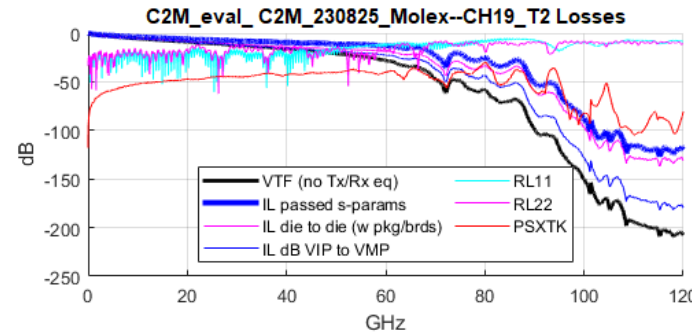
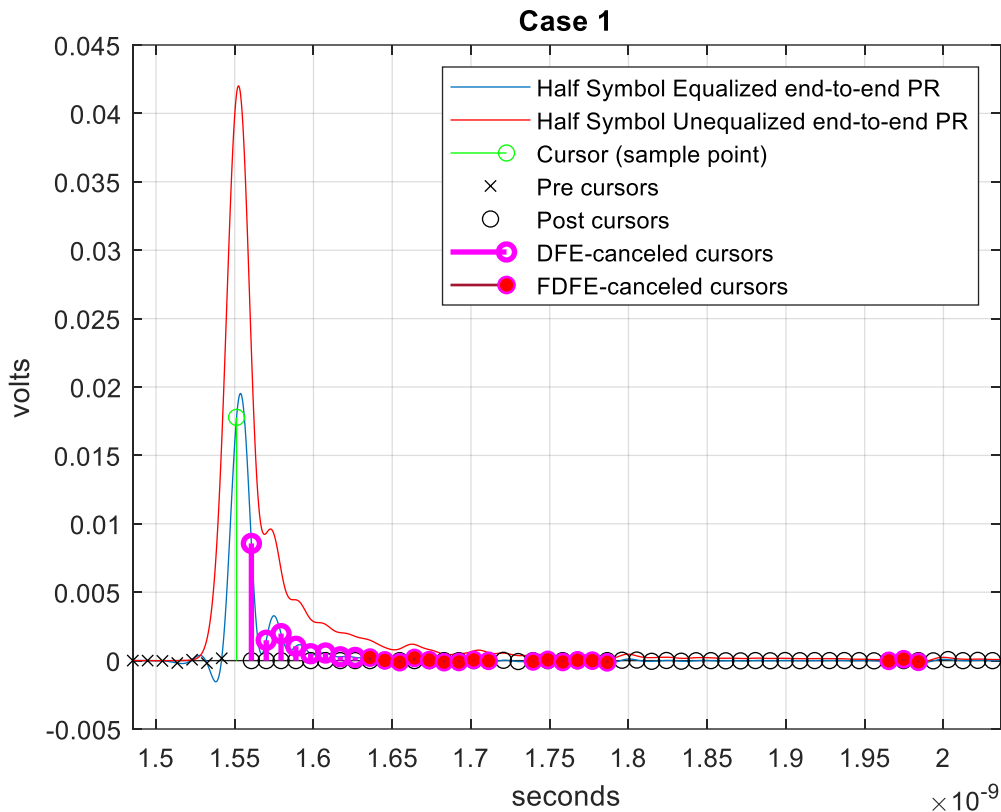

- DFE Taps = 8 + 6x3
- EH = 7.88 mV
- VEC = 12.644 dB
- DER = 1e-6
- COM = 2.31 dB

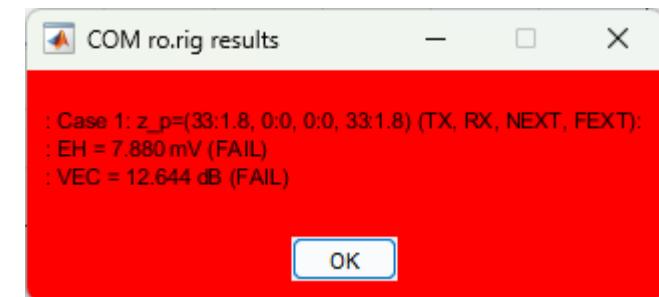

212.5 Gbps PAM4 C2M TP1a Time-Domain Simulation (CH19/Design C)

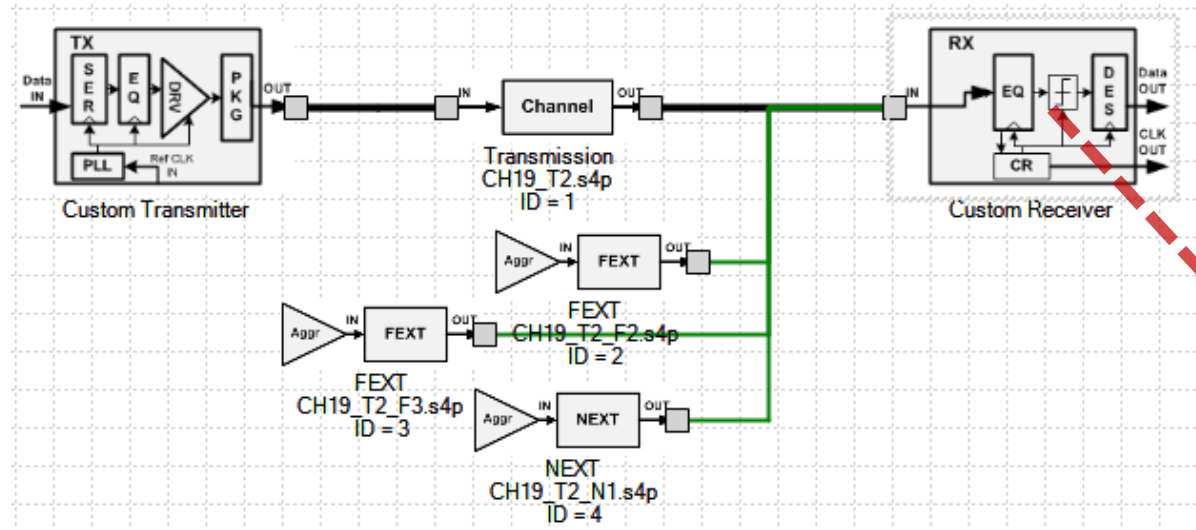

Simulation Configuration

- Test Pattern: PRBS13Q
- Transmitter:
 - RLM = 0.95, $SNR_{TX} = 33\text{dB}$, $BUJ = 0.02U_{pk}$, $RJ = 0.01U_{RMS}$
 - 20%-80% Rise/Fall Time (T_r): 4ps
 - Termination impedance (R_d): 46.25 ohms
 - TX Package:
 - $Z_p = 33\text{mm}$, $Z_{p2} = 1.8\text{mm}$
 - Γ_{a2} , and C_p also updated (see COM table)
- TP1a Reference Receiver (Scope)
 - Based on scaled 802.3ck CR/C2M reference RX with DFE (8 fixed and 6 groups of 3 consecutive floating taps up to 60 UI), and Input Referred Noise = $5 \times 10^{-9} \text{ V}^2/\text{GHz}^*$
 - Termination impedance (R_d): 46.25 ohms
- Channel: C2M channel with 2 FEXTs and 1 NEXT
- $DER = 10^{-6}$

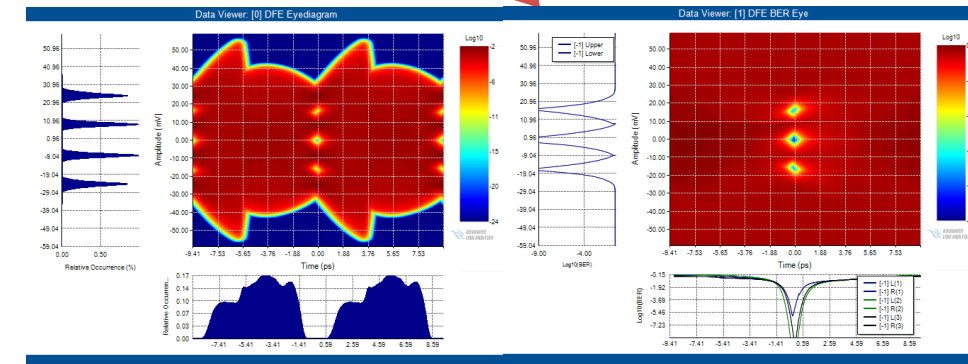

TP1a RX output
EH = 3.58mV, EW = 0.08UI VEC = 10.61dB
@ DER=1e-6

Notes: *: RX optimizes signal-to-noise-and-distortion ratio for CDR and EQ.

COM Analysis and Link Simulation Results Summary & Observations

DER	Channel	COM EH	COM VEC	Simulation Eye Opening Height	Simulation VEC
10^{-6}	CH19	7.88 mV	12.64 dB	3.58 mV	10.61 dB
10^{-5}	CH19	10.73 mV	9.96 dB	4.90 mV	8.64 dB
10^{-4}	CH19	14.02 mV	7.64 dB	6.47 mV	6.71 dB

Correlations between COM and Link Simulations

- Link simulations and COM analysis shown to choose different EQ settings, which led to EH and VEC results differences, due to:
 - Optimization method
 - COM is SBR-based and mostly LTI while link simulations include nonlinear effects such as level mismatch, jitter amplifications, burst errors, ... etc.
 - COM assumes constant noise SNR across the link while noises are shaped by channel/device in link simulations.
- However, when comparing the COM values from COM analysis and link simulation results*, good correlations were observed.

Note: *: COM value can be derived from link simulation's VEC values through following EQ

$$VEC = -20 \log_{10} \left(1 - 10^{\frac{-COM}{20}} \right)$$

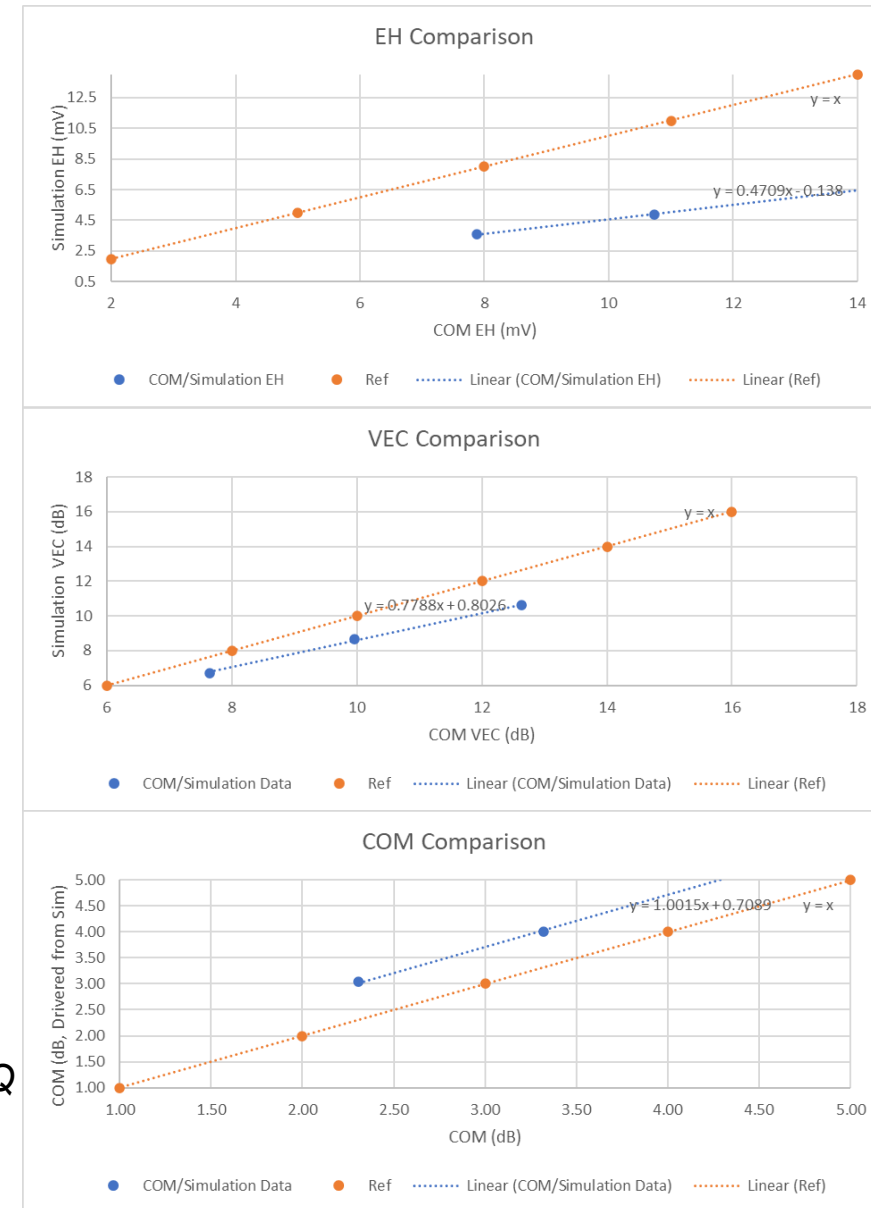

Summary and Next Steps

- Reasonable solution can be found for this C2M “Universal Port” TP0-TP1A channel (Design C) for $DER < 1e-5$.
- Further channel improvements, and/or more capable reference RX equalizer are needed to achieve a reasonable solution for $DER < 1e-6$.
- Future works including TP4 short and long channel design, simulation and analysis, for C2M specification development.

References

- [1] https://www.ieee802.org/3/dj/public/23_05/li_3dj_04_2305.pdf
- [2] https://www.ieee802.org/3/dj/public/23_05/li_3dj_06a_2305.pdf
- [3] https://www.ieee802.org/3/dj/public/23_0720/lim_3dj_02a_2307.pdf