

# Missing pieces of the 802.3dj logic baseline

**IEEE P802.3dj Plenary Meeting**  
**Hawaii November 2023**

Mark Gustlin – Cisco  
Arthur Marris - Cadence  
Gary Nicholl - Cisco  
Matt Brown - Alphawave

# Holes as Pointed out in Matt's Presentation from September 2023

This presentation will address Clause 4, 4A, 31B, 90 and 90A logic holes:

## Legacy clauses to amend (part 1)

Clause #	Clause title	Baseline status	Notes
FM	Front matter	N/A	new front matter
1	Definitions, abbreviations, etc.	N/A	new defs., abbrs., etc.
4	MAC	Incomplete	Add 1.6T
4A	Simplified full duplex media access control	Incomplete	Add 1.6T
30	Management Objects	N/A	New content for 200G, 400G, 800G, and 1.6T
31B	MAC Control PAUSE operation	Incomplete	new content for 1.6T
45	MDIO	N/A	New content for 200G, 400G, 800G, and 1.6T
69	Backplane	N/A	New content for 200G, 400G, 800G, and 1.6T
73	AN	Complete	New content for 200G, 400G, 800G, and 1.6T
90	Ethernet support for time synchronization protocols	Incomplete	New content for 1.6T
90A	Ethernet support for time synchronization protocols	Incomplete	New content for 1.6T

From: [https://www.ieee802.org/3/dj/public/23\\_09/brown\\_3dj\\_01\\_2309.pdf](https://www.ieee802.org/3/dj/public/23_09/brown_3dj_01_2309.pdf)

# Holes as Pointed out in Matt's Presentation from September 2023

And also Clause 118, 170 and 171 logic holes:

## Legacy clauses to amend (part 2)

Clause #	Clause title	Baseline status	Notes
93A	Specs. for Electrical Channels (COM)	Incomplete	New content for 200 Gb/s electrical interfaces (CR, KR, C2C, C2M) Considering new annex for new features.
116	400GE/200GE introduction	N/A	add new 200G and 400G PHY types and sublayers
118	200G/400G extender, XS	Incomplete	add new 200GAUI-1, 400GAUI-2, symbol-mux PMA
119	200G/400G PCS	Complete	add stateless encoder/decoder for 200 Gb/s PHYs
120F	100GAUI-1, 200GAUI-2, 400GAUI-4, 800GAUI-8 C2C	Complete	add 1.6TAUI-16
120G	100GAUI-1, 200GAUI-2, 400GAUI-4, 800GAUI-8 C2M	Complete	add 1.6TAUI-16
169	Introduction to 800GE	N/A	add new 800G PHY types and sublayers
170	800G RS, MII	Incomplete	add 1.6T RS and 1.6TMII
171	800G MII extender, XS	Incomplete	add 1.6T extender and XS, 800GAUI-4, 1.6TAUI-16/8

From: [https://www.ieee802.org/3/dj/public/23\\_09/brown\\_3dj\\_01\\_2309.pdf](https://www.ieee802.org/3/dj/public/23_09/brown_3dj_01_2309.pdf)

# Clause 4 – existing 802.3df for 800G

Change Table 4–2 as follows:

Table 4–2—MAC parameters

Parameters	MAC data rate			
	Up to and including 100 Mb/s	1 Gb/s	2.5 Gb/s, 5 Gb/s, 25 Gb/s, 40 Gb/s, 50 Gb/s, 100 Gb/s, 200 Gb/s, <u>and 400 Gb/s, and 800 Gb/s</u>	10 Gb/s
slotTime	512 bit times	4096 bit times	not applicable	not applicable
interPacketGap <sup>3</sup>	96 bits	96 bits	96 bits	96 bits
attemptLimit	16	16	not applicable	not applicable

Change Note 7 in 4.4.2 as follows:

NOTE 7—For 40 Gb/s, 50 Gb/s, 100 Gb/s, 200 Gb/s, ~~and 400 Gb/s, and 800 Gb/s~~ operation, the received interpacket gap (the spacing between two packets, from the last bit of the FCS field of the first packet to the first bit of the Preamble of the second packet) can have a minimum value of 8 BT (bit times), as measured at the XLGMII, 50GMII, CGMII, 200GMII, ~~or 400GMII, or 800GMII~~ receive signals at the DTE due to clock tolerance and lane alignment requirements.

# Clause 4 and Annex 4A

- Change “Table 4–2—MAC parameters” column heading from:  
“2.5 Gb/s, 5 Gb/s, 25 Gb/s, 40 Gb/s, 50 Gb/s, 100 Gb/s, 200 Gb/s, 400 Gb/s, and 800 Gb/s”
- to:  
“2.5 Gb/s, 5 Gb/s, 25 Gb/s, 40 Gb/s, 50 Gb/s, 100 Gb/s, 200 Gb/s, 400 Gb/s, 800 Gb/s, [and 1.6 Tb/s](#)”
- Change Note 7 in 4.4.2 and Note 4 in 4A.4.2 to read:  
“For 40 Gb/s, 50 Gb/s, 100 Gb/s, 200 Gb/s, 400 Gb/s, 800 Gb/s, [and 1.6 Tb/s](#) operation, the received interpacket gap (the spacing between two packets, from the last bit of the FCS field of the first packet to the first bit of the Preamble of the second packet) can have a minimum value of 8 BT (bit times), as measured at the XLGMII, 50GMII, CGMII, 200GMII, 400GMII, 800GMII, [or 1.6TMII](#) receive signals at the DTE due to clock tolerance and lane alignment requirements.”

# Annex 31B – existing 802.3df for 800G

## 31B.3.7 Timing considerations for PAUSE operation

*Insert the following paragraph into 31B.3.7 after the “At operating speeds of 400 Gb/s, ...” paragraph:*

At operating speeds of 800 Gb/s, a station shall not begin to transmit a (new) frame more than 1810 pause\_quanta after the reception of a valid PAUSE frame that contains a non-zero value of pause\_time, as measured at the MDI

*Insert the following calculation for 800 Gb/s operation into 31B.3.7 after the 400 Gb/s calculation listed with the last paragraph (“The PAUSE response time ...”):*

800 Gb/s – max\_overrun = 115 840 + frame\_length.

# Annex 31B

- **For 1.6T double the 800G numbers:**

## **31B.3.7 Timing considerations for PAUSE operation**

*Insert the following paragraph into 31B.3.7 after the “At operating speeds of 800 Gb/s, ...”) paragraph:*

At operating speeds of 1.6 Tb/s, a station shall not begin to transmit a (new) frame more than 3620 pause\_quanta after the reception of a valid PAUSE frame that contains a non-zero value of pause\_time, as measured at the MDI

*Insert the following calculation for 1.6 Tb/s operation into 31B.3.7 after the 800 Gb/s calculation listed with the last paragraph (“The PAUSE response time ...”):*

1.6 Tb/s – max\_overshoot = 231680 + frame\_length.

- Add PICS item \*Mllq in **31B.4.3 Major capabilities/options**
- Add PICS item TIM18 in **31B.4.6 PAUSE command MAC timing considerations**

# Clause 90 – existing 802.3df for 800G

## 90. Ethernet support for time synchronization protocols

### 90.1 Introduction

*Change the second paragraph of 90.1 as follows:*

The TSSI is defined for the full-duplex mode of operation only. It supports MAC operation at various data rates. The MII (Clause 22), GMII (Clause 35), XGMII (Clause 46), 25GMII (Clause 106), XLGMII (Clause 81), CGMII (Clause 81), 50GMII (Clause 132), 200GMII (Clause 117), ~~and~~ 400GMII (Clause 117), and 800GMII (Clause 170) specifications are all compatible with the generic Reconciliation Sublayer (gRS) defined in 90.5.



# Annex 90A – existing 802.3df for 800G

Table 90A–1—Magnitude of potential timestamp accuracy impairments

Ethernet rate	Magnitude of potential timestamp accuracy impairments per transmit or receive port (ns)			
	Mismatched data delay measurement point <sup>a</sup>	Idle insertion / removal <sup>b,c</sup>	Alignment marker / codeword marker insertion / removal <sup>c</sup>	PCS lane distribution / merging
10M	800	400	N/A	N/A
100M	80	40		N/A
1G	8	16 <sup>d</sup> , 8 <sup>e</sup>		0 <sup>e</sup> , N/A <sup>d</sup>
2.5G	3.2	12.8		N/A <sup>g</sup>
5G	1.6	6.4		N/A <sup>g</sup>
10G	0.8	3.2		N/A <sup>d, f, g, 0<sup>e</sup></sup>
25G	0.32	1.28	10.24	N/A
40G	0.2	1.6	6.4	4.8
50G	0.16	1.28	5.12	3.84
100G	0.08	0.64	12.8	12.16
200G	0.04	0.32	2.56	N/A <sup>g</sup>
400G	0.02	0.16	2.56	N/A <sup>g</sup>
<u>800G</u>	<u>0.01</u>	<u>0.08</u>	<u>2.56</u>	<u>N/A <sup>g</sup></u>

<sup>a</sup> The value shown only accounts for the time between the two data delay measurement point options when they are

# Clause 90 and Annex 90A

- *Change the second paragraph of 90.1 as follows:*
- The TSSI is defined for the full-duplex mode of operation only. It supports MAC operation at various data rates. The MII ([Clause 22](#)), GMII ([Clause 35](#)), XGMII ([Clause 46](#)), 25GMII ([Clause 106](#)), XLGMII ([Clause 81](#)), CGMII ([Clause 81](#)), 50GMII ([Clause 132](#)), 200GMII ([Clause 117](#)), 400GMII ([Clause 117](#)), 800GMII ([Clause 170](#)), [and 1.6TMII \(Clause 170\)](#) specifications are all compatible with the generic Reconciliation Sublayer (gRS) defined in [90.5](#).
- Add line at end of “Table 90A–1—Magnitude of potential timestamp accuracy impairments” for 1.6T using appropriate scaling from 800G values:

Ethernet rate	Mismatched data delay measurement point	Idle insertion / removal	Alignment marker/ codeword marker insertion / removal	PCS lane distribution / merging
1.6T	0.005	0.04	2.56	N/A

# Clause 118

- Update clause 118 to include support for 200G/lane AUIs and corresponding symbol-muxing PMAs
- Add in the new AUIs to section 118.1.3, below are some of the specific items to change/add:
  - 200GAUI-1 chip-to-chip (Annex 120F)
  - 200GAUI-1 module (Annex 120G)
  
  - 400GAUI-2 chip-to-chip (Annex 120F)
  - 400GAUI-2 module (Annex 120G)
- Update Table 118-a (802.3cw), add 200GAUI-1 C2M, 200GAUI-1 C2C, new PMA
- Update Table 118-b (802.3cw), add 400GAUI-2 C2M, 400GAUI-2 C2C, new PMA
- Mark existing Clause 120 PMA as optional in the above tables since they are not used with the new AUIs
- May need some text (e.g., table footnote) to tie the new AUIs to the new PMAs

# Clause 118 cont

- Add in a reference to the symbol muxing PMA (clause TBD, placeholder 302)
  - Use editorial license to add appropriate description and references

# Clause 170

- Add 1.6Tb/s to clause 170 (MII)
  - In addition to the existing 800 Gb/s rate
- The 1.6TMII has the following characteristics:
  - a) It supports a speed of 1.6 Tb/s.
  - b) Data and delimiters are synchronous to a clock reference.
  - c) It provides independent 64-bit wide transmit and receive data paths.
  - d) It supports full duplex operation only.
- Make other changes as necessary
  - Update Figure 170-1 to add the 1.6T stack (similar to Figure 117-1)
  - Delay constraints are on the next page

## 170. Reconciliation Sublayer (RS) and Media Independent Interface for 800 Gb/s (800GMII)

### 170.1 Overview

This clause defines the characteristics of the Reconciliation Sublayer (RS) and the Media Independent Interface between Ethernet media access controllers and various PHYs. Figure 170–1 shows the relationship of the RS and Media Independent Interface to the ISO/IEC OSI reference model.

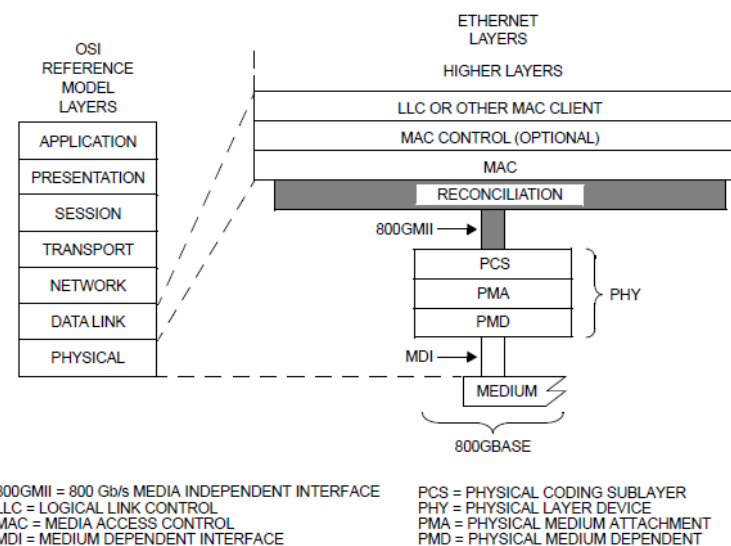

Figure 170–1—RS and MII relationship to the ISO/IEC Open Systems Interconnection (OSI) reference model and IEEE 802.3 Ethernet model

The 800GMII is an optional logical interface between the MAC sublayer and the Physical Layer device (PHY). The 800GMII Extender may optionally be used to extend the 800GMII (see Clause 171).

The RS adapts the bit serial protocols of the MAC to the parallel format of the PCS service interface. Though the 800GMII is an optional interface, it is used in this standard as a basis for specification. The Physical Coding Sublayer (PCS) is specified to the 800GMII, so if not implemented, a conforming implementation shall behave functionally as if the RS and 800GMII were implemented.

# Clause 170 delay constraints

- Existing 800G delay constraints:

Table 170-1—Delay constraints

Sublayer	Maximum (bit time)	Maximum (pause_quanta)	Maximum (ns)
800 Gb/s MAC, RS, and MAC Control	196 608	384	245.76

- Proposed 1.6T delay constraints (a doubling of the bit times from 800G):

Sublayer	Maximum (bit time)	Maximum (pause_quanta)	Maximum (ns)
1.6 Tb/s MAC, RS, and MAC Control	393 216	768	245.76

# Clause 171

- Add 1.6Tb/s to clause 171 (XS)
  - In addition to the existing 800 Gb/s rate
  - Add the 1.6T stack into figure 171-1
- The following is a list of the major functions of the 1.6TMII Extender:
  - Simple signal mapping to the 1.6TMII
  - The optional 1.6TMII Extender can be inserted between the Reconciliation Sublayer and the PHY to transparently extend the reach of the 1.6TMII
  - Independent transmit and receive data paths
  - Each 1.6TXS leverages all functions in the 1.6TBASE-R PCS (see Clause TBD, placeholder 301)
  - Each 1.6TXS connects to a 1.6TAUI-n as shown in Figure 171-x
- Make other changes as necessary, including:
  - Diagram equivalent to figure 171-2 (functional block diagram), 171-3 (layering); but for 1.6T
  - Tables equivalent to tables 172-2, 172-3, 172-4, 172-5 status and control variable mapping; but for 1.6T
  - Service interface definitions, FEC degrade signaling etc.

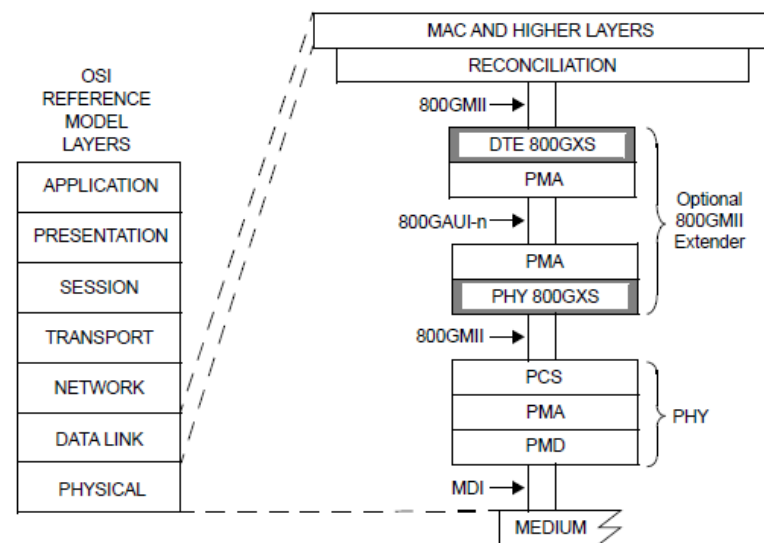

800GAUI-n = 800 Gb/s n-LANE ATTACHMENT UNIT INTERFACE  
800GMII = 800 Gb/s MEDIA INDEPENDENT INTERFACE  
800GXS = 800GMII EXTENDER SUBLAYER  
DTE = DATA TERMINAL EQUIPMENT  
MAC = MEDIA ACCESS CONTROL

MDI = MEDIUM DEPENDENT INTERFACE  
PCS = PHYSICAL CODING SUBLAYER  
PHY = PHYSICAL LAYER DEVICE  
PMA = PHYSICAL MEDIUM ATTACHMENT  
PMD = PHYSICAL MEDIUM DEPENDENT

Figure 171-1—800GXS relationship to the ISO/IEC Open System Interconnection (OSI) reference model and the IEEE 802.3 Ethernet model

## 171.1.1 Summary of functions

The following is a list of the major functions of the 800GMII Extender:

- Simple signal mapping to the 800GMII
- The optional 800GMII Extender can be inserted between the Reconciliation Sublayer and the PHY to transparently extend the reach of the 800GMII
- Independent transmit and receive data paths
- Each 800GXS leverages all functions in the 800GBASE-R PCS (see Clause 172)
- Each 800GXS connects to an 800GAUI-n as shown in Figure 171-1

# Clause 171 cont

- Update Table 171-1, add 800GAUI-4 C2M, 800GAUI-4 C2C, new PMA
  - Mark existing Clause 173 PMAs as optional since they are not used with the new AUIs
  - May need some text (e.g., table footnote) to tie the new AUIs to the new PMAs.
- Add similar table for 1.6T



**Thanks!**