

802.3dj D3.0

Comment Resolution

Optical Topics

Tom Issenhuth (Huawei), Optical Track Lead Editor
Matt Brown (Qualcomm), 802.3dj Chief Editor
Guangcan Mi (Huawei), Optical Track Editor
Roberto Rodes (Coherent), Optical Track Editor

Introduction

- This slide package was assembled by the 802.3dj editorial team to provide background and detailed resolutions to aid in comment resolution.
- Specifically, these slides are for the various optical-track comments.

TDECQ related comments

Comments #465, 466, 70, 468, 221, 469, 220, 472,
473, 470, 308, 448

Reference equalizer tap

#465 Fix the main tap position e.g. at position 4, and add up to 3 more FFE taps as necessary to preserve the FFE's effectiveness. Remove the variable a in Figure 180-10
 □ change to the tap weight too?

Table 180-16—Reference equalizer tap coefficients

Parameter	Symbol	Value	
		Minimum	Maximum
Feed-forward equalizer (FFE) length	N_w	15	18
Number of equalizer pre-cursor taps	—	3	3
Main tap coefficient limit	$w(0)$	0.8	2.5

No update needed for this comment

Parameter	Symbol	Value	
		Minimum	Maximum
Normalized equalizer coefficient limits: $i = -3$ $i = -2$ $i = -1$ $i = 1$ $i = 2$ $i = 3$ $i = 4$ $i = 5$ $i = 6$ $i \geq 7$	$w(i)/w(0)$	-0.15 -0.1 -0.5 -0.6 -0.2 -0.15 -0.15 -0.15 -0.15 -0.1	0.1 0.25 0.1 0.2 0.3 0.15 0.15 0.15 0.15 0.1
Pre-post equalizer coefficient difference limit: $ w(1)/w(0) - b(1) - w(-1)/w(0) $	—	—	0.25
Equalizer DC gain ^a	—	1	
Decision feedback equalizer (DFE) length	N_b	1	
DFE coefficient limit ^b	$b(1)$	0	0.3

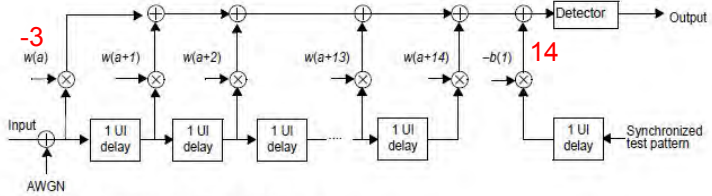

Figure 180-10—TDECQ reference equalizer functional model

^a The sum of all 15 equalizer coefficients, $w(i)$.
^b The DFE coefficient $b(1)$ is referenced to $OMA_{outer}/2$ measured at the input of the FFE equalizer.

Table 180–16—Reference equalizer tap coefficients

Table 180–16—Reference equalizer tap coefficients

Summary of proposed changes

Parameter	Symbol	Value	
		Minimum	Maximum
Feed-forward equalizer (FFE) length	N_w	15	
Number of equalizer pre-cursor taps	—	0	3
Main tap coefficient limit	$w(0)$	0.8	2.5

#466, change limit to 0.95

Parameter	Symbol	Value	
		Minimum	Maximum
Normalized equalizer coefficient limits:	$w(i)/w(0)$		
$i = -3$		-0.15	0.1
$i = -2$		-0.1	0.25
$i = -1$		-0.5	0.1
$i = 1$		-0.6	0.2
$i = 2$		-0.2	0.3
$i = 3$		-0.15	0.15
$i = 4$		-0.15	0.15
$i = 5$		-0.15	0.15
$i = 6$		-0.15	0.15
$i \geq 7$		-0.1	0.1
Pre-post equalizer coefficient difference limit: $ w(1)/w(0) - b(1) - w(-1)/w(0) $	—	—	0.25
Equalizer DC gain ^a	—	1	
Decision feedback equalizer (DFE) length	N_b	1	
DFE coefficient limit ^b	$b(1)$	0	0.3

Need Discussion

#70, change to $|w(1)/w(0) - w(-1)/w(0)|$

#468, change to $w(1)/w(0) - b(1) - w(-1)/w(0)$

Need Discussion

#221, change to 0.33 (w/ OMA_TDECQ)

#469, change to 0.35 w/ OMA_outer, or 0.55 w/ OMA_TDECQ

#220, change to OMA_TDECQ

^a The sum of all 15 equalizer coefficients, $w(i)$.

^b The DFE coefficient $b(1)$ is referenced to $OMA_{outer}/2$ measured at the input of the FFE equalizer.

Histogram spacing and width

Two vertical histograms are measured through the eye diagram, **nominally centered at 0.45 UI and 0.55 UI**. Each of the histogram windows spans all of the modulation levels of the eye diagram, as illustrated in Figure 180–11. The precise time position of the pair of histograms is adjusted to minimize TDECQ while keeping the **histograms spaced 0.1 UI apart**.

472: histogram window spacing change to

- a) 0.09375 UI for 32 s/UI
- b) 0.09 UI for 50 s/UI.

473: histogram window width change to

- c) $1/32 = 0.03125$ UI for 32 s/UI
- d) 0.02 UI for 50 s/UI.

Change "nominally centered at 0.45 UI and 0.55 UI" to

470: "with histogram windows centered 0.1 UI apart.

308: "approximately centered at 0.45 UI and 0.55 UI

Swenson_01a p7: nominally centered at .05 UI before and after sampling phase ϕ_0

Power Budget 448

Power Budget	6.7 7.2	dB
Operating distance	500	m
Channel insertion loss	3	dB
Maximum discrete reflectance	-35	dB
Allocation for penalties	3.7 4.2=3.8+0.2+0.2	dB

TDECQmax MPI DGD

Depending changes:

- Tx OMA_{min}
- Rx Sensitivity
- SRS
- Footnote b where MPI impacts channel insertion loss as shown in Table 180-12

The channel insertion loss of 3 dB shown in this illustrative link power budget is valid for a maximum MPI penalty of 0.1 dB, which depends on the number and value of discrete reflectances present in the link. This channel insertion loss may be reduced by up to 0.5 dB depending on the discrete reflectances in the link as shown in Table 180–12.

Miscellaneous comments

SRS sinusoidal amplitude interferer

Comment I-302

Cl 180 SC 180.9.16 P 492 L 42 # 302

Dudek, Michael Marvell

Comment Type TR Comment Status D Stressed receiver sensitivity (OI)

The frequency of the sinusoidal amplitude interferer in the stressed Rx test is not specified. If its period is significantly longer than a FEC code-word it will cause significant degradation in BLER for the same BER and TECQ due to it significantly increasing the probability of correlated errors

Suggested Remedy

Add an additional exception at line 42. "- The frequency of the sinusoidal interferer is greater than 200MHz. Add the same exception to 181.9.16, 182.9.16 and 183.9.16

Proposed Response Response Status W

180.9.16 Stressed receiver sensitivity

Stressed receiver sensitivity of each lane shall be within the limit given in Table 180-8 if measured using the method defined in 121.8.10 with the following exceptions:

- The SECQ of the stressed receiver conformance test signal is measured according to 180.9.6, except that the test fiber is not used. The transition time of the stressed receiver conformance test signal is no greater than the value specified in Table 180-7.
- With the Gaussian noise generator on and the sinusoidal jitter and sinusoidal interferer turned off, the $RIN_{xx,OMA}$ of the SRS test source should be no greater than the value specified in Table 180-7.
- The signaling rate of the test pattern generator and the extinction ratio of the E/O converter are as given in Table 180-7 using test patterns specified in Table 180-14.
- The required values of the "Stressed receiver sensitivity (OMA_{outer}), each lane (max)", "Stressed eye closure for PAM4 (SECQ), lane under test" and " OMA_{outer} of each aggressor lane" are as given in Table 180-8.

35
36
37
38
39
40
41
42
43
44
45
46
47
48
49

From 121.8.10

The sinusoidally jittered clock represents other forms of jitter and also verifies that the receiver under test can track low-frequency jitter. The sinusoidal amplitude interferer may be set at any frequency between 100 MHz and 2 GHz, although care should be taken to avoid harmonic relationships between the sinusoidal interferer, the sinusoidal jitter, the signaling rate, and the pattern repetition rate. The Gaussian noise generator, the amplitude of the sinusoidal interferer, and the low-pass filter are adjusted so that the SECQ specified in Table 121-7 is met, according to the methods specified in 121.8.10.2.

For PMDs defined in Clause 180 and 181, the repetition rate of the interleave codeword set (4 codewords) is as follows:

200GBASE-DR1: 9.8 MHz (212.5 GHz / (5440*4))

400GBASE-DR2: 20 MHz

800GBASE-DR4/FR4-500: 39 MHz

1.6BASE-DR8: 78 MHz

For PMDs defined in Clause 182 and 183, the repetition rate of the interleave codeword set (12 codewords) is as follows:

200GBASE-DR1-2: 3.2 MHz (212.5 GHz / (5440*12))

400GBASE-DR2-2: 6.5 MHz

800GBASE-DR4-2/FR4/LR4: 13 MHz

1.6BASE-DR8-2: 26 MHz

The suggested remedy seems to both increase the lower limit and remove the upper limit.

Options for new exception:

– “The sinusoidal amplitude interferer may be set at any frequency between 200 MHz and 2 GHz”

– “The sinusoidal amplitude interferer may be set at any frequency greater than 200 MHz”

SRS sinusoidal amplitude interferer

Comment I-302

Text in CL180

Stressed receiver sensitivity of each lane shall be within the limit given in Table 180–8 if measured using the method defined in 121.8.10 with the following exceptions:

- The SECQ of the stressed receiver conformance test signal is measured according to 180.9.6, except that the test fiber is not used.

- The frequency of the sinusoidal interferer is greater than 200MHz.

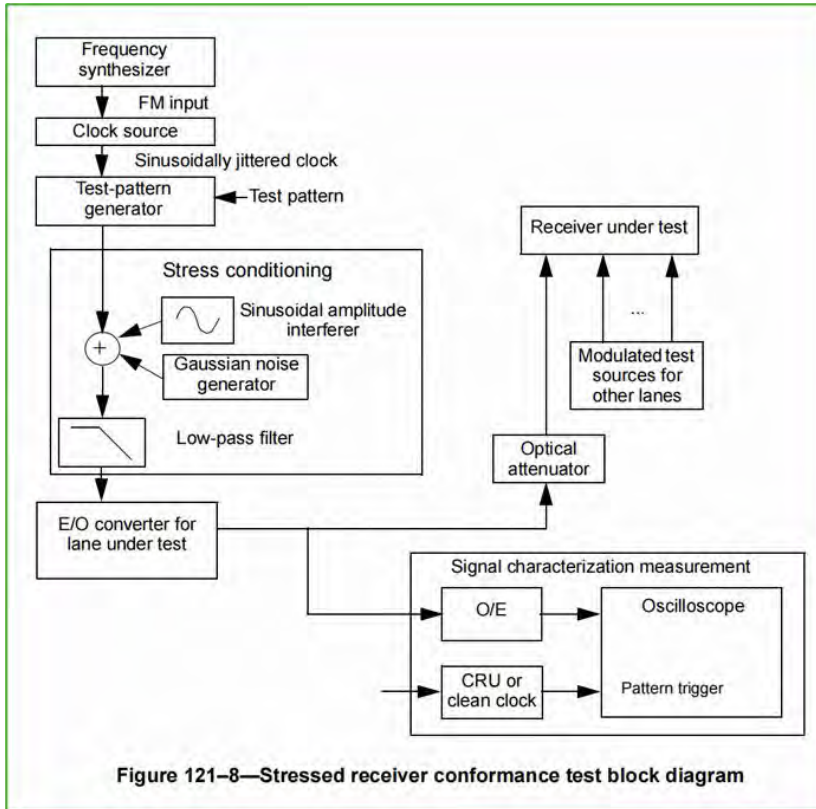

Reference receiver

Comment I-452

CI 180 SC 180.9.2 P 476 L 5 # I-452

Dawe, Piers J G NVIDIA

Comment Type TR Comment Status X

The choice of fourth-order Bessel-Thomson response is a historical accident. Fifth order rolls off a bit steeper at high frequencies, which is more realistic, and has no other significant difference. The better roll-off leads to better measurements. This is also true for measurements where reflections at an instrument's electrical connectors are a concern. This is our chance to make the change, as the industry transitions to a new speed and new test equipment.

Suggested Remedy

Change fourth-order to fifth-order throughout the draft.

Proposed Response Response Status

180.9.2 Reference receiver

A reference receiver is defined for transmitter measurements. The reference receiver, composed of the combination of the O/E converter and the oscilloscope, has a 3 dB bandwidth of approximately 53.125 GHz with a fourth-order Bessel-Thomson response to at least 1.3×106.25 GHz, and at frequencies above 1.3×106.25 GHz, the response should not exceed -20 dB. Compensation may be made for any deviation from an ideal fourth-order Bessel-Thomson response.

The clock recovery unit (CRU) has a corner frequency of 4 MHz and a slope of 20 dB/decade. The CRU may be implemented in hardware or software depending on oscilloscope technology.

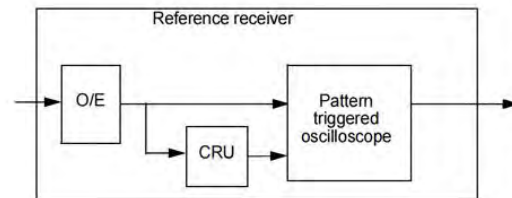

Figure 180–7—Reference receiver block diagram

Block diagram, TP2 patch cord

Comment I-434

CL 180 SC 180.5.1 P 464 L 9 # 434

Dawe, Piers J G NVIDIA

Comment Type TR Comment Status D TP2 figure (OI)

Sometimes this diagram is taken too literally leading to a belief that the 2 to 5 m patch cord and TP2 are part of a service link. They are not; optical cabling may include a variety of connectors (not the type used on test equipment), patch panels, and maybe optical switches, the length of any first patch cord is not regulated, and there may be no accessible TP2.

Suggested Remedy

Either: remove TP2 from the medium, and show the patch cord and TP2 (connected to test equipment) as an alternate;
 or: at line 2 normative text, add: While TP2 and the patch cord for transmitter measurements and tests are shown in Figure 180-2, they are not part of the medium. The transmit MDI is connected to the medium for use, or to the patch cord and TP2 transmitter measurements and tests.

Proposed Response Response Status W

PROPOSED ACCEPT IN PRINCIPLE

Implement the second option, at line 2 normative text, add: While TP2 and the patch cord for transmitter measurements and tests are shown in Figure 180-2, they are not part of the medium. The transmit MDI is connected to the medium for use, or to the patch cord and TP2 for transmitter measurements and tests.

Implement with editorial license and over all optical clauses.

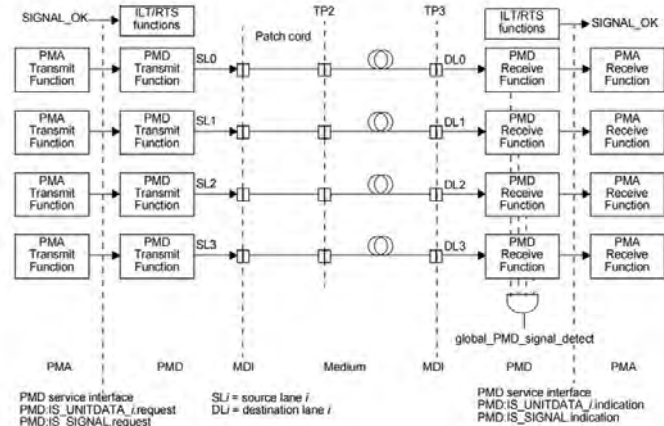

NOTE: For clarity, only one direction of transmission is shown

While TP2 and the patch cord for transmitter measurements and tests are shown in Figure 180-2, they are not part of the medium. The transmit MDI is connected to the medium for use, or to the patch cord and TP2 for transmitter measurements and tests.

For purposes of system conformance, the PMD sublayer is standardized at the points described in this subclause. The optical transmit signal is defined at the output end of a single-mode fiber patch cord (TP2), between 2 m and 5 m in length. Unless specified otherwise, all transmitter measurements and tests defined in 180.9 are made at TP2. The optical receive signal is defined at the output of the fiber optic cabling (TP3)

50
51
52
53
54

at the MDI (see 180.8.3). Unless specified otherwise, all receiver measurements and tests defined in 180.9 are made at TP3

1
2
3

Applicable to CL 180~183

Extinction ratio

Comment I-490

CI 180	SC 180.9.12	P 490	L 4	# I-490
Dawe, Piers J G		NVIDIA		
Comment Type	TR	Comment Status	X	
The definition of extinction ratio can be simplified, and it should be made 100% consistent with the definition of OMA, which is changing.				
<i>Suggested Remedy</i>				
Change "The extinction ratio of a PAM4 optical signal is defined as the ratio of the average optical launch power level P3, measured over ... waveforms captured at the output of the reference receiver defined in 180.9.2.				
to "The extinction ratio of a PAM4 optical signal is defined as the ratio of the average optical launch power levels P3 and P0, as defined for OMA _{outer} (see 180.9.5). In Table 180-14, change the row "Outer optical modulation amplitude (OMA _{outer})"				
to "Outer optical modulation amplitude (OMA _{outer}) and extinction ratio" and delete the separate row for extinction ratio.				
Subclause 180.9.12 could be combined with 180.9.5 also.				
Proposed Response		Response Status	O	

Keep Extinction ratio as a separate row in test pattern
Table 180-14

180.9.5 Outer optical modulation amplitude (OMA_{outer})

The OMA_{outer} of each lane shall be within the limit given in Table 180–7. The OMA_{outer} is measured using a test pattern specified for OMA_{outer} in Table 180–14 as the difference between the average optical launch power level P₃, measured over the central 2 UI of a run of 7 threes, and the average optical launch power level P₀, measured over the central 2 UI of a run of 6 zeros, as shown in Figure 180–8. OMA_{outer} is measured using the waveforms captured at the output of the reference receiver defined in 180.9.2.

180.9.12 Extinction ratio

The extinction ratio of each lane shall be within the limit given in Table 180–7 if measured using a test pattern specified for extinction ratio in Table 180–14. The extinction ratio of a PAM4 optical signal is defined as the ratio of the average optical launch power level P₃, measured over the central 2 UI of a run of 7 threes, and the average optical launch power level P₀, measured over the central 2 UI of a run of 6 zeros, as shown in Figure 180–8. The extinction ratio is measured using waveforms captured at the output of the reference receiver defined in 180.9.2.

The extinction ratio of each lane shall be within the limit given in Table 180–7 if measured using a test pattern specified for extinction ratio in Table 180–14. The extinction ratio of a PAM4 optical signal is defined as the ratio of the average optical launch power levels P₃ and P₀, as defined for OMA_{outer} (see 180.9.5).

TFSEH Cleanup

Comments #43, 121, 122, 123, 124, 293, 481, 485,
486, 487, 488

TFSEH Cleanup

Comments #43, 121, 122, 123, 124, 293, 481, 485, 486, 487, 488

Ci 180 SC 180.9.9 P487 L13 # 43

Issenhuth, Tom Huawei Technologies Co., Ltd.Issenhuth Consulting,

Comment Type T Comment Status D TFSEH (O)

The Transmitter functional symbol error histogram (TFSEH) subclasses should be revised. A supporting presentation with the proposed changes for 180.9.9, 181.9.9, 182.9.9 and 183.9.9 will be provided.

SuggestedRemedy

Update the noted subclasses per the supporting presentation

Proposed Response Response Status W

PROPOSED ACCEPT IN PRINCIPLE

Pending review of the following presentation and CRG discussion:
<URL>icole_3d1_01_2605.pdf

Ci 180 SC 180.9.9.1 P488 L36 # 121

Huber, Thomas Nokia

Comment Type ER Comment Status D TFSEH (O)

Using "FRx" to mean "functional receiver" is very confusing, since FR is also used to indicate the 2 km CWDM PMD family, and "FRx" or "FRn" are commonly used to indicate a set of FR PHYs.

SuggestedRemedy

It appears that "FRx" is used only in the title of the clause and in the first and last sentences of the first paragraph. Delete "FRx" in the title and first sentence, and replace "FRx" with "functional receiver" in the last sentence.

Proposed Response Response Status W

PROPOSED ACCEPT IN PRINCIPLE

Resolve using the response to comment #43

Ci 181 SC 181.9.9 P519 L8 # 122

Huber, Thomas Nokia

Comment Type ER Comment Status D TFSEH (O)

Using "FRx" to mean "functional receiver" is very confusing, since FR is also used to indicate the 2 km CWDM PMD family, and "FRx" or "FRn" are commonly used to indicate a set of FR PHYs.

SuggestedRemedy

It appears that FRx is used only in this bullet point. Delete "FRx" in the first sentence and replace FRx in the last sentence with "functional receiver"

Proposed Response Response Status W

PROPOSED ACCEPT IN PRINCIPLE

Resolve using the response to comment #43

Ci 182 SC 182.9.9 P551 L32 # 123

Huber, Thomas Nokia

Comment Type ER Comment Status D TFSEH (O)

Using "FRx" to mean "functional receiver" is very confusing, since FR is also used to indicate the 2 km CWDM PMD family, and "FRx" or "FRn" are commonly used to indicate a set of FR PHYs.

SuggestedRemedy

It appears that FRx is used only in this bullet point. Delete "FRx" in the first sentence and replace FRx in the last sentence with "functional receiver"

Proposed Response Response Status W

PROPOSED ACCEPT IN PRINCIPLE

Resolve using the response to comment #43

Ci 183 SC 183.9.9 P584 L33 # 124

Huber, Thomas Nokia

Comment Type ER Comment Status D TFSEH (O)

Using "FRx" to mean "functional receiver" is very confusing, since FR is also used to indicate the 2 km CWDM PMD family, and "FRx" or "FRn" are commonly used to indicate a set of FR PHYs.

SuggestedRemedy

It appears that FRx is used only in this bullet point. Delete "FRx" in the first sentence and replace FRx in the last sentence with "functional receiver"

Proposed Response Response Status W

PROPOSED ACCEPT IN PRINCIPLE

Resolve using the response to comment #43

Ci 181 SC 181.9.9 P519 L11 # 293

Dudek, Michael Marvell

Comment Type TR Comment Status D TFSEH (O)

The test calls out a fiber that is compliant to Table 181-13, but that table shows a minimum and maximum chromatic dispersion, so a patch cord is compliant to that table. This test is intended to include the effects of chromatic dispersion. The proposed solution uses the same channel as the TDECQ test.

SuggestedRemedy

Implement the changes proposed in issenhuth_3d1_01a_2603.pdf

Proposed Response Response Status W

PROPOSED ACCEPT IN PRINCIPLE

Resolve using the response to comment #43

Ci 180 SC 180.9.9 P487 L13 # 481

Dawe, Piers J G NVIDIA

Comment Type TR Comment Status D TFSEH (O)

A real compliant receiver will have better jitter tolerance and other properties than a spec-worst receiver, so "passing" transmitter-receiver pairs can contain unsatisfactory transmitters because of the lack of receiver calibration.

SuggestedRemedy

Calibrate the receiver or delete the subclause.

Proposed Response Response Status W

PROPOSED ACCEPT IN PRINCIPLE

Resolve using the response to comment #43

Ci 180 SC 180.9.9.1 P489 L16 # 485

Dawe, Piers J G NVIDIA

Comment Type TR Comment Status D TFSEH (O)

Estimating actual MPI and DGD penalty is impractical; we don't do it for TDECQ with much the same channel. MPI depends on transmitter and receiver as well as channel. But we expect that for a decent test channel in the lab, with good well-maintained connectors and typical not-worst-case fibre, these will be very small.

SuggestedRemedy

Delete Test_fiber_MPI+DGD_penalty or delete the subclause.

Proposed Response Response Status W

PROPOSED ACCEPT IN PRINCIPLE

Resolve using the response to comment #43

Ci 180 SC 180.9.9.1 P488 L40 # 486

Dawe, Piers J G NVIDIA

Comment Type TR Comment Status D TFSEH (O)

AGCs have levels but attenuators have attenuations

SuggestedRemedy

Change "VOA_level" to "OA" for optical attenuation

Proposed Response Response Status W

PROPOSED ACCEPT IN PRINCIPLE

Resolve using the response to comment #43

Ci 180 SC 180.9.9.1 P488 L40 # 487

Dawe, Piers J G NVIDIA

Comment Type TR Comment Status D TFSEH (O)

This is 802.3. We specify observable signals at compliance points. In the context of an optical spec, "DUT" will be interpreted as device = optical module, while what is intended to be tested is the transmitter under test as it says on line 44, and what is actually tested is a transmitter-receiver pair.

SuggestedRemedy

Change "DUT" to "PUT", and when the receiver calibration is sorted out, change to "TUT".

Proposed Response Response Status W

PROPOSED ACCEPT IN PRINCIPLE

Resolve using the response to comment #43

Ci 180 SC 180.9.9.1 P488 L50 # 488

Dawe, Piers J G NVIDIA

Comment Type TR Comment Status D TFSEH (O)

Variable names with @ in the middle is horrible. Programming languages won't tolerate it.

SuggestedRemedy

Don't do it.

Proposed Response Response Status W

PROPOSED ACCEPT IN PRINCIPLE

Resolve using the response to comment #43

TFSEH Cleanup

Proposed replacement text for 180.9.9 - clean

180.9.9 Transmitter functional test (TFT)

The transmitter functional test uses a functional receiver (FRx) defined in 180.9.9.1 to measure a transmitter functional symbol error histogram (TFSEH) defined in 180.9.9.2. A block diagram showing the functional receiver is shown in Figure 180–12. The transmitter under test is connected to the functional receiver by a test fiber which meets the requirements in 180.9.6.2. Full compliance with 180.9.6.2 requires the test fiber to provide back reflection with polarization state resulting in the greatest RIN. Other test fibers, including patch cords, may be used for additional tests.

The transmitter under test is configured with precoding set appropriately for the functional receiver being used in the test. The appropriate precoding state may be communicated via the ILT function or by other means.

The test block error histograms are measured using the method described in 174A.9.3.

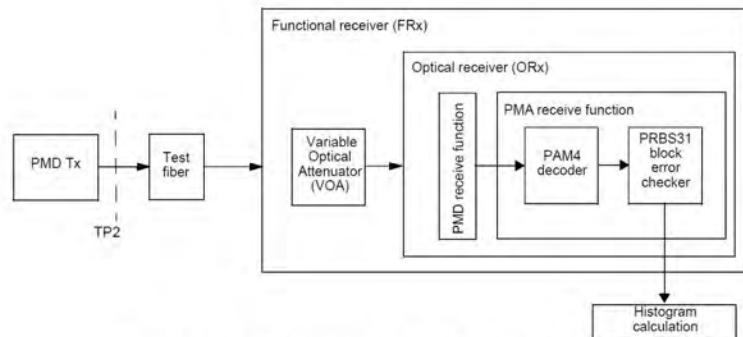

Figure 180–12—Transmitter functional test block diagram

TFSEH Cleanup

Proposed replacement text for 180.9.9 - working

180.9.9 Transmitter functional test (TFT)

The transmitter functional test uses a functional receiver (FRx) defined in 180.9.9.1 to measure a transmitter functional symbol error histogram (TFSEH) defined in 180.9.9.2. A block diagram showing the functional receiver is shown in Figure 180–12. The transmitter under test is connected to the functional receiver by a test fiber which meets the requirements in 180.9.6.2. Full compliance with 180.9.6.2 requires the test fiber to provide back reflection with polarization state resulting in the greatest RIN. Other test fibers, including patch cords, may be used for additional tests.

The transmitter under test is configured with precoding set appropriately for the functional receiver being used in the test. The appropriate precoding state may be communicated via the ILT function or by other means.

The test block error histograms are measured using the method described in 174A.9.3.

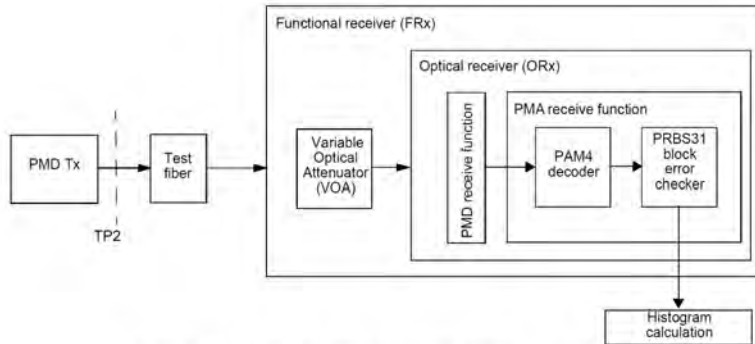

Figure 180–12—Transmitter functional test block diagram

TFSEH Cleanup

Proposed replacement text for 180.9.9.1 - clean

180.9.9.1 Functional receiver (FRx) definition

The functional receiver (FRx) is a variable optical attenuator (VOA) followed by an optical receiver (ORx) that complies with the characteristics in Table 180–8. The VOA and test fiber approximate the compliance channel as given in Table 180–15. The VOA level is set to the value given by Equation (180–1), in which the first and second terms normalize differences in test fibers and optical receivers, respectively, so that symbol error counts are repeatable across different conditions.

$$VOA_level = Test_fiber_correction + ORx_TECQ_correction - Test_margin \quad (180-1)$$

where:

Test_fiber_correction is given by Equation (180–2), and is the difference between the power budget used to determine the transmitter under test OMA_{outer} (min) and the best estimate of the test fiber power budget

ORx_TECQ_correction is the difference between receiver sensitivity (max) as given in Table 180–8 and ORx receiver sensitivity, both at transmitter under test TECQ, and is given by Equation (180–5)

Test_margin is the additional *ORx_OMA*, to improve SNR of the transmitter functional test. It equals 1.5 dB, which decreases the required ORx operating BER to 2.4×10^{-5}

$$Test_fiber_correction = Tx_DUT_power_budget - Test_fiber_power_budget \quad (180-2)$$

where:

Tx_DUT_power_budget is the transmitter under test power budget except instead of the TDECQ max value, uses the TDECQ value measured over the test fiber specified in Table 180–9, and is given by Equation (180–3)

Test_fiber_power_budget is the power budget of the test fiber using the best estimates of the test fiber channel insertion loss, MPI and DGD penalties, and TDECQ of the DUT over the test fiber and is given by Equation (180–4)

TFSEH Cleanup

Proposed replacement text for 180.9.9.1 - working

180.9.9.1 Functional receiver (FRx) definition

The functional receiver (FRx) is a variable optical attenuator (VOA) followed by an optical receiver (ORx) that complies with the characteristics in Table 180–8. The VOA and test fiber approximate the compliance channel as given in Table 180–15. The VOA level is set to the value given by Equation (180–1), in which the first and second terms normalize differences in test fibers and optical receivers, respectively, so that symbol error counts are repeatable across different conditions.

$$\text{VOA_level} = \text{Test_fiber_correction} + \text{ORx_TECQ_correction} - \text{Test_margin}$$

where:

Test_fiber_correction is given by Equation (180–2), and is the difference between the power budget used to determine the transmitter under test OMA_{outer} (min) and the best estimate of the test fiber power budget

ORx_TECQ_correction is the difference between receiver sensitivity (max) as given in Table 180–8 and ORx receiver sensitivity, both at transmitter under test TECQ, and is given by Equation (180–5)

Test_margin is the additional ORx_OMA, to improve SNR of the transmitter functional test. It equals 1.5 dB, which decreases the required ORx operating BER to 2.4×10^{-5}

$$\text{Test_fiber_correction} = \text{Tx_DUT_power_budget} - \text{Test_fiber_power_budget}$$

where:

Tx_DUT_power_budget is the transmitter under test power budget except instead of the TDECQ max value, uses the TDECQ value measured over the test fiber specified in Table 180–9, and is given by Equation (180–3)

Test_fiber_power_budget is the power budget of the test fiber using the best estimates of the test fiber channel insertion loss, MPI and DGD penalties, and TDECQ of the DUT over the test fiber and is given by Equation (180–4)

TFSEH Cleanup

Proposed replacement text for 180.9.9.1 - clean

$$Tx_DUT_power_budget = Channel_insertion_loss + MPI_and_DGD_penalties_allocation + \max(DUT_TECQ, DUT_TDECQ) \quad (180-3)$$

where:

Channel_insertion_loss is the “Channel insertion loss” as given in Table 180–9
MPI_and_DGD_penalties_allocation is the allocation for MPI and DGD penalties as given in Table 180–9
DUT_TECQ is the measured TECQ for the transmitter under test
DUT_TDECQ is the measured TDECQ for the transmitter under test

$$Test_fiber_power_budget = Test_fiber_loss + Test_fiber_MPI_and_DGD_penalties + Test_fiber_DUT_TDECQ \quad (180-4)$$

where:

Test_fiber_loss is the best estimate of the actual channel insertion loss of the test fiber
Test_fiber_MPI_and_DGD_penalties is the best estimate of the actual MPI and DGD penalties of the test fiber
Test_fiber_DUT_TDECQ is the best estimate of the transmitter under test actual TDECQ value over the test fiber. An example estimate is the measured *DUT_TECQ* value plus the best estimate of the actual transmitter under test CD penalty over the test fiber

$$ORx_TECQ_correction = RxS_OMA_max_at_DUT_TECQ - ORx_RxS_OMA_at_DUT_TECQ \quad (180-5)$$

where:

RxS_OMA_max_at_DUT_TECQ is the receiver sensitivity OMA (max) spec at the measured TECQ of the transmitter under test
ORx_RxS_OMA_at_DUT_TECQ is the actual ORx receiver sensitivity OMA at the TECQ measured for the transmitter under test

TFSEH Cleanup

Proposed replacement text for 180.9.9.1 - working

$$\text{Tx_DUT_power_budget} = \text{Channel_insertion_loss} + \text{MPI_and_DGD_penalties_allocation} + \max(\text{DUT_TECQ}, \text{DUT_TDECQ})$$

where:

Channel_insertion_loss is the “Channel insertion loss” as given in Table 180–9
MPI_and_DGD_penalties_allocation is the allocation for MPI and DGD penalties as given in Table 180–9
DUT_TECQ is the measured TECQ for the transmitter under test
DUT_TDECQ is the measured TDECQ for the transmitter under test

$$\text{Test_fiber_power_budget} = \text{Test_fiber_loss} + \text{Test_fiber_MPI_and_DGD_penalties} + \text{Test_fiber_DUT_TDECQ}$$

where:

Test_fiber_loss is the best estimate of the actual channel insertion loss of the test fiber
Test_fiber_MPI_and_DGD_penalties is the best estimate of the actual MPI and DGD penalties of the test fiber
Test_fiber_DUT_TDECQ is the best estimate of the transmitter under test actual TDECQ value over the test fiber. An example estimate is the measured
DUT_TECQ value plus the best estimate of the actual transmitter under test CD penalty over the test fiber

$$\text{ORx_TECQ_correction} = \text{RxS_OMA_max_at_DUT_TECQ} - \text{ORx_RxS_OMA_at_DUT_TECQ}$$

where:

RxS_OMA_max_at_DUT_TECQ is the receiver sensitivity OMA (max) spec at the measured TECQ of the transmitter under test
ORx_RxS_OMA_at_DUT_TECQ is the actual ORx receiver sensitivity OMA at the TECQ measured for the transmitter under test

TFSEH Cleanup

Proposed replacement text for 180.9.9.2 - clean

180.9.9.2 Test functional symbol error histogram (TFSEH)

The transmitter functional symbol error histogram mask for each lane is given in Table 180–18 and is measured using the test pattern as given in Table 180–14.

The limit $H_{\max}(k)$ is calculated using the method in 174A.9.5 using ORx operating $\text{BER} = 2.4 \times 10^{-5}$ and

$p = 1$. This operating BER is *ORx_RxS* BER decreased by amount corresponding to *Test_margin* increase of *ORx_RxS_OMA*. This improves the measurement SNR of the transmitter functional test. ORx and *Test_margin* are defined in 180.9.9.1.

Minimum measurement time is 60 seconds.

A probable failure is indicated by exceeding the transmitter functional symbol error histogram mask defined in Table 180–18, or by one or more counts in test symbol errors k per test block with k greater than 8.

TFSEH Cleanup

Proposed replacement text for 180.9.9.2 - working

180.9.9.2 Test functional symbol error histogram (TFSEH)

The transmitter functional symbol error histogram mask for each lane is given in Table 180–18 and is measured using the test pattern as given in Table 180–14.

The limit $H_{\max}(k)$ is calculated using the method in 174A.9.5 using ORx operating BER = 2.4×10^{-5} and $p = 1$. This operating BER is ORx_RxS BER decreased by amount corresponding to Test_margin increase of ORx_RxS_OMA. This improves the measurement SNR of the transmitter functional test. ORx and Test_margin are defined in 180.9.9.1.

Minimum measurement time is 60 seconds.

A probable failure is indicated by exceeding the transmitter functional symbol error histogram mask defined in Table 180–18, or by one or more counts in test symbol errors k per test block with k greater than 8.

TFSEH Cleanup

Proposed replacement text for 180.9.9.2 - clean

Table 180–18—Transmitter functional symbol error mask

Test symbol errors per test block, k (see 174A.9.5)	Probability $H_{\max}(k)$
1	1.15×10^{-1}
2	7.47×10^{-3}
3	3.24×10^{-4}
4	1.05×10^{-5}
5	2.73×10^{-7}
6	5.88×10^{-9}
7	1.08×10^{-10}
8	1.75×10^{-12}

Editor's note: In "Table 180-14 Mapping of parameters to test patterns and related subclauses" change the parameter name "Transmitter functional symbol error histogram" to "Transmitter functional test".

TFSEH Cleanup

Proposed replacement text for 180.9.9.2 - working

180.9.9.2 Test functional symbol error histogram (TFSEH)

Table 180-18 Transmitter functional symbol error mask

<u>Test symbol errors per test block, k (see 174A.9.5)</u>	<u>Probability Hmax(k)</u>
1	1.15×10^{-1}
2	7.47×10^{-3}
3	3.24×10^{-4}
4	1.05×10^{-5}
5	2.73×10^{-7}
6	5.88×10^{-9}
7	1.08×10^{-10}
8	1.75×10^{-12}

Editor's note: In "Table 180-14 Mapping of parameters to test patterns and related subclauses" change the parameter name "Transmitter functional symbol error histogram" to "Transmitter functional test".

TFSEH Cleanup

Proposed replacement text for 181.9.9 - clean

181.9.9 Transmitter functional test

The transmitter functional symbol error histogram is measured using the method defined in 180.9.9 with the following exceptions:

- The transmitter under test is connected to the functional receiver by a test fiber which meets the requirements in 181.9.6.1. Full compliance with 181.9.6.1 requires the test fiber to provide back reflection with polarization state resulting in the greatest RIN. Other test fibers, including patch cords, may be used for additional tests.

where in 180.9.9.1

- The functional receiver (FRx) is a variable optical attenuator (VOA) followed by an optical receiver (ORx) that complies with characteristics as given in Table 181-6. VOA and the test fiber approximate the compliance channel as given in Table 181-13.

where in Equation (180-2)

- *Tx DUT power budget* is the transmitter under test power budget for the specific test fiber as given in Table 181-7, except uses measured instead of max TDECQ value and is given by Equation (180-3).

where in Equation (180-3)

- *Channel insertion loss* is the “Channel insertion loss” as given in Table 181-7.
- *MPI and DGD penalties allocation* is the allocation for MPI and DGD penalties as given in Table 181-7.

where in 180.9.9.2

- The transmitter functional symbol error histogram mask per each lane is given in Table 180-18 and is measured using the test pattern as given in Table 181-12.

Editor's note: In "Table 181-12 Mapping of parameters to test patterns and related subclauses" change the parameter name "Transmitter functional symbol error histogram" to "Transmitter functional test".

TFSEH Cleanup

Proposed replacement text for 181.9.9 - working

181.9.9 Transmitter functional test

The transmitter functional symbol error histogram is measured using the method defined in 180.9.9 with the following exceptions:

The transmitter under test is connected to the functional receiver by a test fiber which meets the requirements in 181.9.6.1. Full compliance with 181.9.6.1 requires the test fiber to provide back reflection with polarization state resulting in the greatest RIN. Other test fibers, including patch cords, may be used for additional tests.

where in 180.9.9.1

The functional receiver (FRx) is a variable optical attenuator (VOA) followed by an optical receiver (ORx) that complies with characteristics as given in Table 181–6. VOA and the test fiber approximate the compliance channel as given in Table 181–13.

where in Equation (180–2)

$T_{x_DUT_power_budget}$ is the transmitter under test power budget for the specific test fiber as given in Table 181–7, except uses measured instead of max TDECQ value and is given by Equation (180–3).

where in Equation (180–3)

$Channel_insertion_loss$ is the “Channel insertion loss” as given in Table 181–7.

$MPI_and_DGD_penalties_allocation$ is the allocation for MPI and DGD penalties as given in Table 181–7.

where in 180.9.9.2

The transmitter functional symbol error histogram mask per each lane is given in Table 180–18 and is measured using the test pattern as given in Table 181–12.

Editor’s note: In “Table 181-12 Mapping of parameters to test patterns and related subclauses” change the parameter name “Transmitter functional symbol error histogram” to “Transmitter functional test”.

TFSEH Cleanup

Proposed replacement text for 182.9.9 - clean

182.9.9 Transmitter functional test

The transmitter functional symbol error histogram is measured using the method defined in 180.9.9 with the following exceptions:

- The transmitter under test is connected to the functional receiver by a test fiber which meets the requirements in 182.9.6.1. Full compliance with 182.9.6.1 requires the test fiber to provide back reflection with polarization state resulting in the greatest RIN. Other test fibers, including patch cords, may be used for additional tests.

where in 180.9.9.1

- The functional receiver (FRx) is a variable optical attenuator (VOA) followed by an optical receiver (ORx) that complies with characteristics as given in Table 182–8. VOA and the test fiber approximate the compliance channel as given in Table 182–15.

where in Equation (180–2)

- *Tx_DUT_power_budget* is the transmitter under test power budget for the specific fiber under test as given in Table 182–9, except uses measured instead of max TDECQ value and is given by Equation (180–3).

where in Equation (180–3)

- *Channel_insertion_loss* is the “Channel insertion loss” as given in Table 182–9.
- *MPI_and_DGD_penalties_allocation* is the allocation for MPI and DGD penalties as given in Table 182–9.

where in 180.9.9.2

- The transmitter functional symbol error histogram mask per each lane is given in Table 180–18 and is measured using the test pattern as given in Table 182–14.

Editor's note: In "Table 182-14 Mapping of parameters to test patterns and related subclauses" change the parameter name "Transmitter functional symbol error histogram" to "Transmitter functional test".

TFSEH Cleanup

Proposed replacement text for 182.9.9 - working

182.9.9 Transmitter functional test

The transmitter functional symbol error histogram is measured using the method defined in 180.9.9 with the following exceptions:

The transmitter under test is connected to the functional receiver by a test fiber which meets the requirements in 182.9.6.1. Full compliance with 182.9.6.1 requires the test fiber to provide back reflection with polarization state resulting in the greatest RIN. Other test fibers, including patch cords, may be used for additional tests.

where in 180.9.9.1

The functional receiver (FRx) is a variable optical attenuator (VOA) followed by an optical receiver (ORx) that complies with characteristics as given in Table 182–8. VOA and the test fiber approximate the compliance channel as given in Table 182–15.

where in Equation (180–2)

Tx_DUT_power_budget is the transmitter under test power budget for the specific fiber under test as given in Table 182–9, except uses measured instead of max TDECQ value and is given by Equation (180–3).

where in Equation (180–3)

Channel_insertion_loss is the “Channel insertion loss” as given in Table 182–9.

MPI_and_DGD_penalties_allocation is the allocation for MPI and DGD penalties as given in Table 182–9.

where in 180.9.9.2

The transmitter functional symbol error histogram mask per each lane is given in Table 180–18 and is measured using the test pattern as given in Table 182–14.

Editor’s note: In “Table 182-14 Mapping of parameters to test patterns and related subclauses” change the parameter name “Transmitter functional symbol error histogram” to “Transmitter functional test”.

TFSEH Cleanup

Proposed replacement text for 183.9.9 - clean

183.9.9 Transmitter functional test

The transmitter functional symbol error histogram is measured using the method defined in 180.9.9 with the following exceptions:

- The transmitter under test is connected to the functional receiver by a test fiber which meets the requirements in 183.9.6.1. Full compliance with 183.9.6.1 requires the test fiber to provide back reflection with polarization state resulting in the greatest RIN. Other test fibers, including patch cords, may be used for additional tests.

where in 180.9.9.1

- The functional receiver (FRx) is a variable optical attenuator (VOA) followed by an optical receiver (ORx) that complies with characteristics as given in Table 183–7. VOA and the test fiber approximate the compliance channel as given in Table 183–15.

where in Equation (180–2)

- *T_x DUT power budget* is the transmitter under test power budget for the specific fiber under test as given in Table 183–8, except uses measured instead of max TDECQ value and is given by Equation (180–3).

where in Equation (180–3)

- *Channel insertion loss* is the “Channel insertion loss” as given in Table 183–8.
- *MPI and DGD penalties allocation* is the allocation for MPI and DGD penalties as given in Table 183–8.

where in 180.9.9.2

- The transmitter functional symbol error histogram mask per each lane is given in Table 180–18 and is measured using the test pattern as given in Table 183–14.

Editor's note: In "Table 183-14 Mapping of parameters to test patterns and related subclauses" change the parameter name "Transmitter functional symbol error histogram" to "Transmitter functional test".

TFSEH Cleanup

Proposed replacement text for 183.9.9 - working

183.9.9 Transmitter functional test

The transmitter functional symbol error histogram is measured using the method defined in 180.9.9 with the following exceptions:

The transmitter under test is connected to the functional receiver by a test fiber which meets the requirements in 183.9.6.1. Full compliance with 183.9.6.1 requires the test fiber to provide back reflection with polarization state resulting in the greatest RIN. Other test fibers, including patch cords, may be used for additional tests.

where in 180.9.9.1

The functional receiver (FRx) is a variable optical attenuator (VOA) followed by an optical receiver (ORx) that complies with characteristics as given in Table 183–7. VOA and the test fiber approximate the compliance channel as given in Table 183–15.

where in Equation (180–2)

Tx_DUT_power_budget is the transmitter under test power budget for the specific fiber under test as given in Table 183–8, except uses measured instead of max TDECQ value and is given by Equation (180–3).

where in Equation (180–3)

Channel_insertion_loss is the “Channel insertion loss” as given in Table 183–8.

MPI_and_DGD_penalties_allocation is the allocation for MPI and DGD penalties as given in Table 183–8.

where in 180.9.9.2

The transmitter functional symbol error histogram mask per per each lane is given in Table 180–18 and is measured using the test pattern as given in Table 183–14.

Editor’s note: In “Table 183-14 Mapping of parameters to test patterns and related subclauses” change the parameter name “Transmitter functional symbol error histogram” to “Transmitter functional test”.

Receiver Sensitivity

Receiver Sensitivity - SEH

Comments #44, 295, 493, 93, 226, 296

Receiver sensitivity

Comments #44, 295, 493, 93, 226, 296

Cf 180 SC 180.9.15 P491 L1 # 44

Issenhuth, Tom Huawei Technologies Co., Ltd./Issenhuth Consulting,
 Comment Type T Comment Status D Rx sensitivity (O)

The receiver sensitivity subclauses should be revised. A supporting presentation with the proposed changes for 180.9.15, 181.9.15, 182.9.15 and 183.9.15 will be provided.

SuggestedRemedy
 Update the noted subclauses per the supporting presentation

Proposed Response Response Status W
 PROPOSED ACCEPT IN PRINCIPLE.
 Pending review of the following presentation and CRG discussion.
 <URL>coile_3dJ_01_2605.pdf

Cf 180 SC 180.9.15 P491 L22 # 295

Dudek, Michael Marvell
 Comment Type E Comment Status D Rx sensitivity (O)

This comment is a re-submission of comment #101 against D2.3 where it was ruled out of scope but encouraged to be resubmitted. It would be better to describe the precoding before the details of the BLER test in this Receiver Sensitivity and stressed receiver sensitivity sub sections.

SuggestedRemedy
 Move "Precoding (see 176.7.1.2) is enabled if the receiver requests precoding using the ILT function." to page 491 line 10. Also in 180.9.16. Make the equivalent changes in clauses 181, 182 and 183.

Proposed Response Response Status W
 PROPOSED ACCEPT IN PRINCIPLE.
 Resolve using the response to comment #44.

Cf 180 SC 180.9.15 P491 L3 # 493

Dave, Piers J G NVIDIA
 Comment Type TR Comment Status D Rx sensitivity (O)

Receiver sensitivity is a property of the lanes together ("interface BER" concept), not each lane separately. We ensure that each transmit lane is good enough, and each channel lane. We test a receiver by applying the same optical power on each lane, but the receiver can share its error allocation across its lanes how it chooses, just as it can allocate errors to LSB and MSB within a lane as it chooses. This is what happens naturally if the errors are checked at the PCS. 174A.9.5 says "If this test passes for each lane, then the PHY or xMII Extender will meet the expected codeword error ratio. If this test fails, then the performance may be further verified using the method in 174A.9.6 or 174A.9.7."

SuggestedRemedy
 Delete "of each lane" here and in 180.9.16. In Table 180-5, the table entries are optical powers which are by lane, not error ratios which are not, so maybe "each lane" can stay there, although it is misleading.

Proposed Response Response Status W
 PROPOSED REJECT.
 In Table 180-5, the row is Receiver sensitivity (OMAouter), each lanec (max), the word "each lane" in the sentence matches the description in the Table. Even if we delete each lane, it reads "The receiver sensitivity (OMAouter) of each lane shall be within the limits given in Table 180-5 if measured using a test pattern for receiver sensitivity in Table 180-14". When the reader goes to Table 180-5, it still implies that receiver sensitivity of each lane has a maximum value of xx dBm. Deleting each lane doesn't improve the clarity of the draft.

Cf 180 SC 180.9.15 P491 L20 # 93

Ran, Adee Cisco Systems, Inc.
 Comment Type TR Comment Status D Rx sensitivity - SHE (O)

The definition of n in the NOTE is:
 "where n is the largest value of k, where all bins from 0 to n have a count greater than 2"

This is awkward ("where" twice) and, strictly speaking, incorrect: if all bins from 0 to n have a count greater than 2 then n is likely not the largest value of k.

n should be the largest number of k that satisfies a condition that is independent of n.

Also applies to the similar comments in 180.9.16, 181.9.15, 181.9.16, 182.9.15, 182.9.16, 183.9.15, and 183.9.16.

SuggestedRemedy
 Change the quoted phrase to
 "where n is the largest value of k for which all bins from 0 to k have a count greater than 2".

Make the same change in 180.9.16, 181.9.15, 181.9.16, 182.9.15, 182.9.16, 183.9.15, and 183.9.16.

Proposed Response Response Status W
 PROPOSED ACCEPT IN PRINCIPLE.
 Implement the suggested remedy with editorial license.

Cf 180 SC 180.9.15 P491 L18 # 226

Manloff, Eric Ciena Corporation
 Comment Type TR Comment Status D Rx sensitivity - SHE (O)

Current text for block error extrapolation performs a linear fit from 1 to n. Because this is unlikely to be linear, it would be more accurate to only extrapolate over the 4 highest bins with sufficient counts.

SuggestedRemedy
 Replace: "If the statistical projection is modeled accurately by a linear fit extrapolation, a means to provide statistical projection of the measured histograms (see 174A.9.3) in order to reduce test time follows. Extrapolate the measured histogram to Hm(i)(16) using a line determined by a linear fit of log10(Hm(i)(k)), for k = 1 to n, where n is the largest value of k, where all bins from 0 to n have a count greater than 2."

With

"If the statistical projection is modeled accurately by a linear fit extrapolation, a means to provide statistical projection of the measured histograms (see 174A.9.3) in order to reduce test time follows. Extrapolate the measured histogram to Hm(i)(16) using a line determined by a linear fit of log10(Hm(i)(k)), for k = n-3 to n, where n is the largest value of k, where all bins from n-3 to n have a count greater than 2." Make similar changes in Clauses 181, 182, 183.

Proposed Response Response Status W
 PROPOSED ACCEPT IN PRINCIPLE.
 This comment suggests to add more details to the extrapolation method of the block error histogram measurement for receiver sensitivity and SRS. Another method was proposed in 296. The two comments will be addressed together. A joint contribution is planned.
 Pending review of the following presentation and CRG discussion.
 <manloff_01_3dJ_2605>

Cf 180 SC 180.9.15 P491 L18 # 296

Dudek, Michael Marvell
 Comment Type T Comment Status D Rx sensitivity - SHE (O)

The note could be misinterpreted as suggesting extrapolation is also needed for higher probabilities resulting in failures with random errors where the measurements meet the requirement without extrapolation

SuggestedRemedy
 Insert "for Hm(i)(k) less than 10^-6 before "Extrapolate the measured histogram..." Also in 180.9.16. Make the equivalent changes in clauses 181, 182 and 183.

Proposed Response Response Status W
 PROPOSED ACCEPT IN PRINCIPLE.
 Resolve using the response to comment #226

Receiver sensitivity

Proposed replacement text for 180.9.15 - Clean

180.9.15 Receiver sensitivity

The receiver sensitivity (OMA_{outer}) of each lane shall be within the limits given in Table 180–8 if measured at the signaling rate given in Table 180–8 using a test pattern specified for receiver sensitivity in Table 180–14. The conformance test signal applied at TP3 meets the transmitter requirements in Table 180–7 followed by an attenuator.

The TECQ of the conformance test signal is measured according to 180.9.6, except that the test fiber is not used. The measured value of TECQ is then used to calculate the limit for receiver sensitivity (OMA_{outer}) as specified in Table 180–8.

Precoding (see 176.7.1.2) is enabled if the receiver requests precoding using the ILT function.

The measured receiver sensitivity is the lowest value of OMA_{outer} where the PMD receiver meets the BLER requirements in 180.2, measured at the PMA using the test method in either 174A.9.5, 174A.9.6, or 174A.9.7 with parameters provided in Table 180–20. The error mask $H_{max}(k)$ to be used in the method of 174A.9.5 is provided in Table 180–21.

The Low-stressed Receiver Sensitivity (LRS) conformance test signal at TP3 meets the transmit characteristics given in Table 180–7 except for characteristics in Table 180–19.

Receiver sensitivity

Proposed replacement text for 180.9.15 - Clean

Table 180–19—LRS conformance test signal exceptions to transmit characteristics

Parameter	Reference	Value	Unit
TECQ (max)	180.9.8	1.8	dB
TECQ (min)	180.9.8	1.4	dB
Overshoot and undershoot (max)	180.9.10	10	%
Extinction ratio (max)	180.9.12	5.5	dB
Extinction ratio (min)	180.9.12	4.5	dB
Transition time (max)	180.9.13	6.5	ps
Transition time (min)	180.9.13	4.5	ps
ORL tolerance (max)	—	15.5	dB

NOTE—When measuring receiver sensitivity of a complete PHY at the PCS using the method of 174A.11 (see 180.2), a different value of BER_{added} is required.

NOTE—If the statistical projection is modeled accurately by a linear fit extrapolation, a means to provide statistical projection of the measured histograms (see 174A.9.3) in order to reduce test time follows. Extrapolate the measured histogram to $H_m^{(i)}(16)$ using a line determined by a linear fit of $\log_{10}(H_m^{(i)}(k))$, for $k = 1$ to n , where n is the largest value of k , where all bins from 0 to n have a count greater than 2.

Receiver sensitivity

Proposed replacement text for 180.9.15 - Clean

Table 180–20—Error ratio parameters

Parameter	Value
P	
200GBASE-DR1	1
400GBASE-DR2	2
800GBASE-DR4	4
1.6TBASE-DR8	8
BLER limit	1.45×10^{-11}
BER_{total}	2.921×10^{-4}
BER_{added}	6.4×10^{-5}
BER_{max}	2.28×10^{-4}

Receiver sensitivity

Proposed replacement text for 180.9.15 - Clean

Table 180–21—Receiver error mask

Test symbol errors per test block, k (see 174A.9.5)	Probability $H_{\max}(k)$			
	$p = 1$	$p = 2$	$p = 4$	$p = 8$
1	3.6×10^{-1}	3.3×10^{-1}	2.3×10^{-1}	1.3×10^{-1}
2	2.2×10^{-1}	1.0×10^{-1}	3.5×10^{-2}	1.0×10^{-2}
3	9.2×10^{-2}	2.1×10^{-2}	3.6×10^{-3}	5.1×10^{-4}
4	2.8×10^{-2}	3.3×10^{-3}	2.7×10^{-4}	1.9×10^{-5}
5	7.0×10^{-3}	4.0×10^{-4}	1.6×10^{-5}	5.5×10^{-7}
6	1.4×10^{-3}	4.1×10^{-5}	8.2×10^{-7}	1.3×10^{-8}
7	2.5×10^{-4}	3.5×10^{-6}	3.5×10^{-8}	2.7×10^{-10}
8	3.9×10^{-5}	2.7×10^{-7}	1.3×10^{-9}	4.7×10^{-12}
9	5.2×10^{-6}	1.8×10^{-8}	4.1×10^{-11}	7.1×10^{-14}
10	6.4×10^{-7}	1.1×10^{-9}	1.2×10^{-12}	9.6×10^{-16}
11	7.1×10^{-8}	5.8×10^{-11}	3.1×10^{-14}	1.2×10^{-17}
12	7.2×10^{-9}	2.9×10^{-12}	7.5×10^{-16}	1.3×10^{-19}
13	6.7×10^{-10}	1.3×10^{-13}	1.6×10^{-17}	1.2×10^{-21}
14	5.8×10^{-11}	5.6×10^{-15}	3.3×10^{-19}	1.1×10^{-23}
15	4.7×10^{-12}	2.2×10^{-16}	6.1×10^{-21}	9.1×10^{-26}
16	3.8×10^{-13}	8.3×10^{-18}	1.1×10^{-22}	6.9×10^{-28}

Receiver sensitivity

Proposed replacement text for 180.9.15 - working

180.9.15 Receiver sensitivity

The receiver sensitivity (OMA_{outer}) of each lane shall be within the limits given in Table 180–8 if measured at the signaling rate given in Table 180–8 using a test pattern for specified receiver sensitivity in Table 180–14. The conformance test signal applied at TP3 meets the transmitter requirements in Table 180–7 followed by an attenuator.

The TECQ of the conformance test signal is measured according to 180.9.6, except that the test fiber is not used. The measured value of TECQ is then used to calculate the limit for receiver sensitivity (OMA_{outer}) as specified in Table 180–8.

Precoding (see 176.7.1.2) is enabled if the receiver requests precoding using the ILT function.

The measured receiver sensitivity is the lowest value of OMA_{outer} where the PMD receiver meets the BLER requirements in 180.2, measured at the PMA using the test method in either 174A.9.5, 174A.9.6, or 174A.9.7 with parameters provided in Table 180–20. The error mask $H_{max}(k)$ to be used in the method of 174A.9.5 is provided in Table 180–21.

The Low-stressed Receiver Sensitivity (LRS) conformance test signal at TP3 meets the transmit characteristics given in Table 180–7 except for characteristics in Table 180–19.

Receiver sensitivity

Proposed replacement text for 180.9.15 - working

Table 180-19 LRS conformance test signal exceptions to transmit characteristics

<u>Parameter</u>	<u>Reference</u>	<u>Value</u>	<u>Unit</u>
TECQ (max)	180.9.8	1.8	dB
TECQ (min)	180.9.8	1.4	dB
Overshoot and undershoot (max)	180.9.10	10	%
Extinction ratio (max)	180.9.12	5.5	dB
Extinction ratio (min)	180.9.12	4.5	dB
Transition time (max)	180.9.13	6.5	ps
Transition time (min)	180.9.13	4.5	ps
ORL tolerance (max)	—	15.5	dB

NOTE—When measuring receiver sensitivity of a complete PHY at the PCS using the method of 174A.11 (see 180.2), a different value of BER_{added} is required.

NOTE—If the statistical projection is modeled accurately by a linear fit extrapolation, a means to provide statistical projection of the measured histograms (see 174A.9.3) in order to reduce test time follows. Extrapolate the measured histogram to $H_m(i)(16)$ using a line determined by a linear fit of $\log_{10}(H_m(i)(k))$, for $k = 1$ to n , where n is the largest value of k , where all bins from 0 to n have a count greater than 2.

Receiver sensitivity

Proposed replacement text for 180.9.15 - working

Table 180-20 Error ratio parameters

<u>Parameter</u>	<u>Value</u>
P	
200GBASE-DR1	1
400GBASE-DR2	2
800GBASE-DR4	4
1.6TBASE-DR8	8
BLER limit	1.45×10^{-11}
BER_{total}	2.921×10^{-4}
BER_{added}	6.4×10^{-5}
BER_{max}	2.28×10^{-4}

Receiver sensitivity

Proposed replacement text for 180.9.15 - working

Table 180-21 Receiver error mask

Test symbol errors per test block, k (see 174A.9.5)

	Probability Hmax(k)			
	<u>p=1</u>	<u>p=2</u>	<u>p=4</u>	<u>p=8</u>
1	3.6×10^{-1}	3.3×10^{-1}	2.3×10^{-1}	1.3×10^{-1}
2	2.2×10^{-1}	1.0×10^{-1}	3.5×10^{-2}	1.0×10^{-2}
3	9.2×10^{-2}	2.1×10^{-2}	3.6×10^{-3}	5.1×10^{-4}
4	2.8×10^{-2}	3.3×10^{-3}	2.7×10^{-4}	1.9×10^{-5}
5	7.0×10^{-3}	4.0×10^{-4}	1.6×10^{-5}	5.5×10^{-7}
6	1.4×10^{-3}	4.1×10^{-5}	8.2×10^{-7}	1.3×10^{-8}
7	2.5×10^{-4}	3.5×10^{-6}	3.5×10^{-8}	2.7×10^{-10}
8	3.9×10^{-5}	2.7×10^{-7}	1.3×10^{-9}	4.7×10^{-12}
9	5.2×10^{-6}	1.8×10^{-8}	4.1×10^{-11}	7.1×10^{-14}
10	6.4×10^{-7}	1.1×10^{-9}	1.2×10^{-12}	9.6×10^{-16}
11	7.1×10^{-8}	5.8×10^{-11}	3.1×10^{-14}	1.2×10^{-17}
12	7.2×10^{-9}	2.9×10^{-12}	7.5×10^{-16}	1.3×10^{-19}
13	6.7×10^{-10}	1.3×10^{-13}	1.6×10^{-17}	1.2×10^{-21}
14	5.8×10^{-11}	5.6×10^{-15}	3.3×10^{-19}	1.1×10^{-23}
15	4.7×10^{-12}	2.2×10^{-16}	6.1×10^{-21}	9.1×10^{-26}
16	3.8×10^{-13}	8.3×10^{-18}	1.1×10^{-22}	6.9×10^{-28}

Receiver sensitivity

Proposed replacement text for 181.9.15 - clean

181.9.15 Receiver sensitivity

The receiver sensitivity (OMA_{outer}) of each lane shall be within the limits given in Table 181–6 if measured at the signaling rate given in Table 181–6 using a test pattern specified for receiver sensitivity in Table 181–12. The conformance test signal applied at TP3 meets the transmitter requirements in Table 181–5 followed by an attenuator. An optical demultiplexer may be used to separate the lane having the wavelength for the lane under test as specified in Table 181–6 for calibrating the TECQ.

The TECQ of the conformance test signal is measured according to 181.9.8, except that the test fiber is not used. The measured value of TECQ is then used to calculate the limit for receiver sensitivity (OMA_{outer}) as specified in Table 181–6.

Precoding (see 176.7.1.2) is enabled if the receiver requests precoding using the ILT function.

The measured receiver sensitivity is the lowest value of OMA_{outer} where the PMD receiver meets the BLER requirements in 181.2, measured at the PMA using the test method in either 174A.9.5, 174A.9.6, or 174A.9.7 with parameters provided in Table 180–20 and $p = 4$. The error mask $H_{max}(k)$ to be used in the method of 174A.9.5 is provided in Table 180–21 in the column for $p = 4$.

The Low-stressed Receiver Sensitivity (LRS) conformance test signal at TP3 meets the transmit characteristics given in Table 181–5 except for characteristics in Table 180–19 with references in 181.9.

NOTE—When measuring receiver sensitivity of a complete PHY at the PCS using the method of 174A.11 (see 181.2), a different value of BER_{added} is required.

NOTE—If the statistical projection is modeled accurately by a linear fit extrapolation, a means to provide statistical projection of the measured histograms (see 174A.9.3) in order to reduce test time follows. Extrapolate the measured histogram to $H_m^{(i)}(16)$ using a line determined by a linear fit of $\log_{10}(H_m^{(i)}(k))$, for $k = 1$ to n , where n is the largest value of k , where all bins from 0 to n have a count greater than 2.

Receiver sensitivity

Proposed replacement text for 181.9.15 - working

181.9.15 Receiver sensitivity

The receiver sensitivity (OMA_{outer}) of each lane shall be within the limits given in Table 181–6 if measured at the signaling rate given in Table 181–6 using a test pattern specified for receiver sensitivity in Table 181–12. The conformance test signal applied at TP3 meets the transmitter requirements in Table 181–5 followed by an attenuator. An optical demultiplexer may be used to separate the lane having the wavelength for the lane under test as specified in Table 181–6 for calibrating the TECQ.

The TECQ of the conformance test signal is measured according to 181.9.8, except that the test fiber is not used. The measured value of TECQ is then used to calculate the limit for receiver sensitivity (OMA_{outer}) as specified in Table 181–6.

Precoding (see 176.7.1.2) is enabled if the receiver requests precoding using the ILT function.

The measured receiver sensitivity is the lowest value of OMA_{outer} where the PMD receiver meets the BLER requirements in 181.2, measured at the PMA using the test method in either 174A.9.5, 174A.9.6, or 174A.9.7 with parameters provided in Table 180–20 and $p = 4$. The error mask $H_{max}(k)$ to be used in the method of 174A.9.5 is provided in Table 180–21 in the column for $p = 4$.

The Low-stressed Receiver Sensitivity (LRS) conformance test signal at TP3 meets the transmit characteristics given in Table 181–5 except for characteristics in Table 180–19 with references in 181.9.

NOTE—When measuring receiver sensitivity of a complete PHY at the PCS using the method of 174A.11 (see 181.2), a different value of BER_{added} is required.

NOTE—If the statistical projection is modeled accurately by a linear fit extrapolation, a means to provide statistical projection of the measured histograms (see 174A.9.3) in order to reduce test time follows. Extrapolate the measured histogram to $H_m(i)(16)$ using a line determined by a linear fit of $\log_{10}(H_m(i)(k))$, for $k = 1$ to n , where n is the largest value of k , where all bins from 0 to n have a count greater than 2.

Receiver sensitivity

Proposed replacement text for 182.9.15 - clean

182.9.15 Receiver sensitivity

The receiver sensitivity (OMA_{outer}) of each lane shall be within the limits given in Table 182–8 if measured at the signaling rate given in Table 182–8 using a test pattern specified for receiver sensitivity in Table 182–14. The conformance test signal applied at TP3 meets the transmitter requirements in Table 182–7 followed by an attenuator.

The TECQ of the conformance test signal is measured according to 182.9.6, except that the test fiber is not used. The measured value of TECQ is then used to calculate the limit for receiver sensitivity (OMA_{outer}) as specified in Table 182–8.

Precoding (see 176.7.1.2) is enabled if the receiver requests precoding using the ILT function.

The measured receiver sensitivity is the lowest value of OMA_{outer} where the receiver meets the BLER requirements in 182.2 using the test method in either 174A.9.5, 174A.9.6, or 174A.9.7 with parameters provided in Table 182-18. The error mask $H_{max}(k)$ to be used in the method of 174A.9.5 is provided in Table 180–21.

The Low-stressed Receiver Sensitivity (LRS) conformance test signal at TP3 meets the transmit characteristics given in Table 182–7 except for characteristics in Table 180–19 with references in 182.9.

NOTE—When measuring receiver sensitivity of a complete PHY at the PCS using the method of 174A.11 (see 182.2), a different value of BER_{added} is required.

NOTE—If the statistical projection is modeled accurately by a linear fit extrapolation, a means to provide statistical projection of the measured histograms (see 174A.9.3) in order to reduce test time follows. Extrapolate the measured histogram to $H_m^{(i)}(16)$ using a line determined by a linear fit of $\log_{10}(H_m^{(i)}(k))$, for $k = 1$ to n , where n is the largest value of k , where all bins from 0 to n have a count greater than 2.

Receiver sensitivity

Proposed replacement text for 182.9.15 - working

182.9.15 Receiver sensitivity

The receiver sensitivity (OMA_{outer}) of each lane shall be within the limits given in Table 182–8 if measured at the signaling rate given in Table 182–8 using a test pattern specified for receiver sensitivity in Table 182–14. The conformance test signal applied at TP3 meets the transmitter requirements in Table 182–7 followed by an attenuator.

The TECQ of the conformance test signal is measured according to 182.9.6, except that the test fiber is not used. The measured value of TECQ is then used to calculate the limit for receiver sensitivity (OMA_{outer}) as specified in Table 182–8.

Precoding (see 176.7.1.2) is enabled if the receiver requests precoding using the ILT function.

The measured receiver sensitivity is the lowest value of OMA_{outer} where the PMD receiver meets the BLER requirements in 181.2, measured at the PMA using the test method in either 174A.9.5, 174A.9.6, or 174A.9.7 with parameters provided in Table 180–20 and $p = 4$. The error mask $H_{max}(k)$ to be used in the method of 174A.9.5 is provided in Table 180–21.

The Low-stressed Receiver Sensitivity (LRS) conformance test signal at TP3 meets the transmit characteristics given in Table 182–7 except for characteristics in Table 180–19 with references in 182.9.

NOTE—When measuring receiver sensitivity of a complete PHY at the PCS using the method of 174A.11 (see 181.2), a different value of BER_{added} is required.

NOTE—If the statistical projection is modeled accurately by a linear fit extrapolation, a means to provide statistical projection of the measured histograms (see 174A.9.3) in order to reduce test time follows. Extrapolate the measured histogram to $H_m(i)(16)$ using a line determined by a linear fit of $\log_{10}(H_m(i)(k))$, for $k = 1$ to n , where n is the largest value of k , where all bins from 0 to n have a count greater than 2.

Receiver sensitivity

Proposed replacement text for 180.9.9.2 - clean

Table 182-18 — Error ratio parameters

Parameter	Value
P	
200GBASE-DR1-2	1
400GBASE-DR2-2	2
800GBASE-DR4-2	4
1.6TBASE-DR8-2	8
BLER limit	1.45×10^{-11}
BER_{total}	2.921×10^{-4}
BER_{added}	6.4×10^{-5}
BER_{max}	2.28×10^{-4}

Receiver sensitivity

Proposed replacement text for 180.9.9.2 - working

Table 182-18 Error ratio parameters

<u>Parameter</u>	<u>Value</u>
P	
200GBASE-DR1-2	1
400GBASE-DR2-2	2
800GBASE-DR4-2	4
1.6TBASE-DR8-2	8
BLER limit	1.45×10^{-11}
BER_{total}	2.921×10^{-4}
BER_{added}	6.4×10^{-5}
BER_{max}	2.28×10^{-4}

Receiver sensitivity

Proposed replacement text for 183.9.15 - clean

183.9.15 Receiver sensitivity

The receiver sensitivity (OMA_{outer}) of each lane shall be within the limits given in Table 183–7 if measured at the signaling rate given in Table 183–7 using a test pattern specified for receiver sensitivity in Table 183–14. The conformance test signal applied at TP3 meets the transmitter requirements in Table 183–6 followed by an attenuator. An optical demultiplexer may be used to separate the lane having the wavelength for the lane under test as specified in Table 183–7 for calibrating the TECQ.

The TECQ of the conformance test signal is measured according to 183.9.8, except that the test fiber is not used. The measured value of TECQ is then used to calculate the limit for receiver sensitivity (OMA_{outer}) as specified in Table 183–7.

Precoding (see 176.7.1.2) is enabled if the receiver requests precoding using the ILT function.

The measured receiver sensitivity is the lowest value of OMA_{outer} where the PMD receiver meets the BLER requirement in 183.2 using the test method in either 174A.9.5, 174A.9.6, or 174A.9.7 with parameters provided in Table 182–18 and $p = 4$. The error mask $H_{max}(k)$ to be used in the method of 174A.9.5 is provided in Table 180–21 in the column for $p = 4$.

The Low-stressed Receiver Sensitivity (LRS) conformance test signal at TP3 meets the transmit characteristics given in Table 183–7 except for characteristics in Table 180–19 with references in 183.9.

NOTE—When measuring receiver sensitivity of a complete PHY at the PCS using the method of 174A.11 (see 183.2), a different value of BER_{added} is required.

NOTE—If the statistical projection is modeled accurately by a linear fit extrapolation, a means to provide statistical projection of the measured histograms (see 174A.9.3) in order to reduce test time follows. Extrapolate the measured histogram to $H_m^{(i)}(16)$ using a line determined by a linear fit of $\log_{10}(H_m^{(i)}(k))$, for $k = 1$ to n , where n is the largest value of k , where all bins from 0 to n have a count greater than 2.

Receiver sensitivity

Proposed replacement text for 183.9.15 - working

183.9.15 Receiver sensitivity

The receiver sensitivity (OMA_{outer}) of each lane shall be within the limits given in Table 183–7 if measured at the signaling rate given in Table 183–7 using a test pattern specified for receiver sensitivity in Table 183–14. The conformance test signal applied at TP3 meets the transmitter requirements in Table 183–6 followed by an attenuator. An optical demultiplexer may be used to separate the lane having the wavelength for the lane under test as specified in Table 183–7 for calibrating the TECQ.

The TECQ of the conformance test signal is measured according to 183.9.8, except that the test fiber is not used. The measured value of TECQ is then used to calculate the limit for receiver sensitivity (OMA_{outer}) as specified in Table 183–7.

Precoding (see 176.7.1.2) is enabled if the receiver requests precoding using the ILT function.

The measured receiver sensitivity is the lowest value of OMA_{outer} where the PMD receiver meets the BLER requirements in 181.2, measured at the PMA using the test method in either 174A.9.5, 174A.9.6, or 174A.9.7 with parameters provided in Table 182–18. The error mask $H_{max}(k)$ to be used in the method of 174A.9.5 is provided in Table 180–21 in the column for $p = 4$.

The Low-stressed Receiver Sensitivity (LRS) conformance test signal at TP3 meets the transmit characteristics given in Table 183–7 except for characteristics in Table 180–19 with references in 183.9.

NOTE—When measuring receiver sensitivity of a complete PHY at the PCS using the method of 174A.11 (see 182.2), a different value of BER_{added} is required.

NOTE—If the statistical projection is modeled accurately by a linear fit extrapolation, a means to provide statistical projection of the measured histograms (see 174A.9.3) in order to reduce test time follows. Extrapolate the measured histogram to $H_m(i)(16)$ using a line determined by a linear fit of $\log_{10}(H_m(i)(k))$, for $k = 1$ to n , where n is the largest value of k , where all bins from 0 to n have a count greater than 2.