

Reference transmitter data in support of receiver sensitivity specification proposal (Comment #44)

Derek Kita, Oğulcan Örsel, and Christian Reimer

All authors are affiliated with and employed by HyperLight Corp.

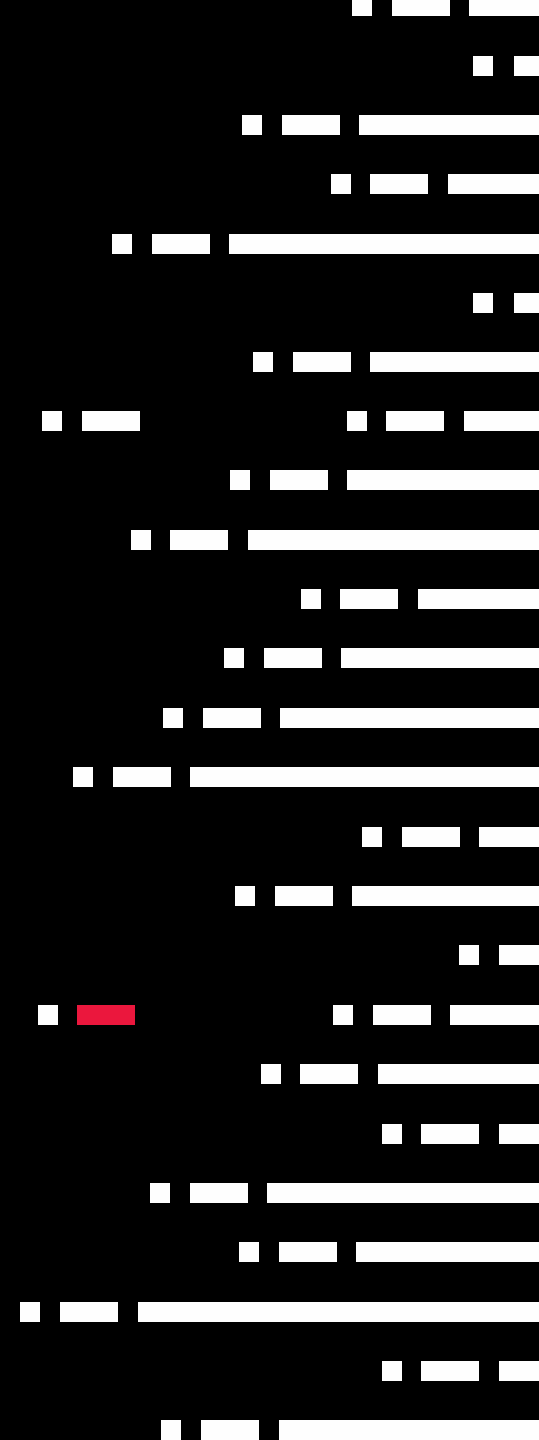

Context

- The March "RxS Specification Proposal" (https://www.ieee802.org/3/dj/public/26_03/cole_3dj_01_2603.pdf) defines starting point transmitter requirements for a conformance test signal used to measure the low-stressed receiver sensitivity (OMAouter).
- The proposal Author Team requested supporting data from participants.
- This is reference transmitter data in support of the proposed Conformance Test Signal specification and d3.0 Comment #44

Table 180-19-Conformance test signal LRS transmit characteristics exceptions to Table 180-7

Parameter	Reference	DRn	Unit
TECQ (max)	180.9.8	1.8	dB
TECQ (min)	180.9.8	1.4	dB
Overshoot and undershoot (max)	180.9.10	10	%
Extinction ratio (max)	180.9.12	5.5	dB
Extinction ratio (min)	180.9.12	4.5	dB
Transition time (max)	180.9.13	6.5	ps
Transition time (min)	180.9.13	4.5	ps
ORL tolerance (max)	-	15.5	dB

Reference Transmitter Details

- OSFP form factor
- Utilizes standard 1.6T (200G / lane) DSP
- 3 dBm typical AOP
- > 5 dB modulated ER

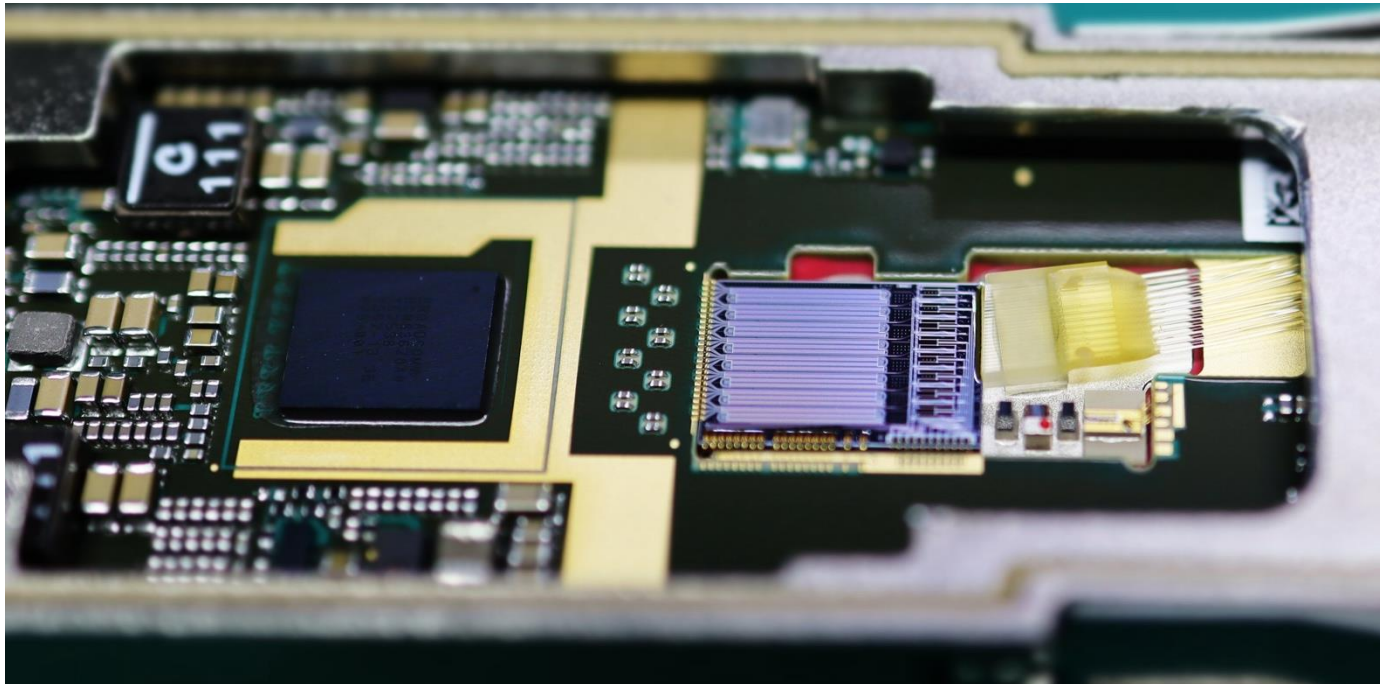

Measurement setup

Configuration 1: DCA triggered by 1/8 rate external clock

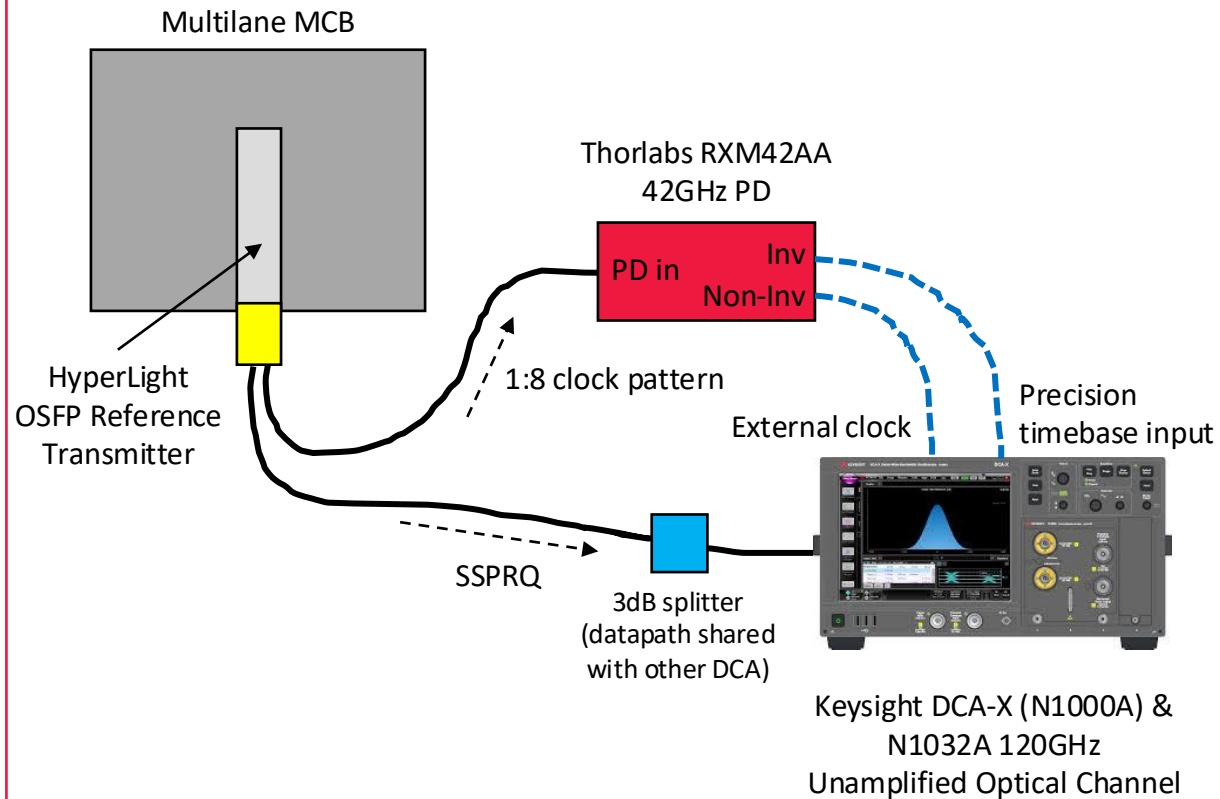

Additional measurement details:

- All testing at 1310nm wavelength, room temperature
- Each lane running at 212.5Gbps PAM-4
- 802.3dj Draft 2.3 DR (500m) reference receiver (minus the DFE)
- Measurements captured on both DCAs simultaneously

Configuration 2: DCA with integrated clock recovery unit

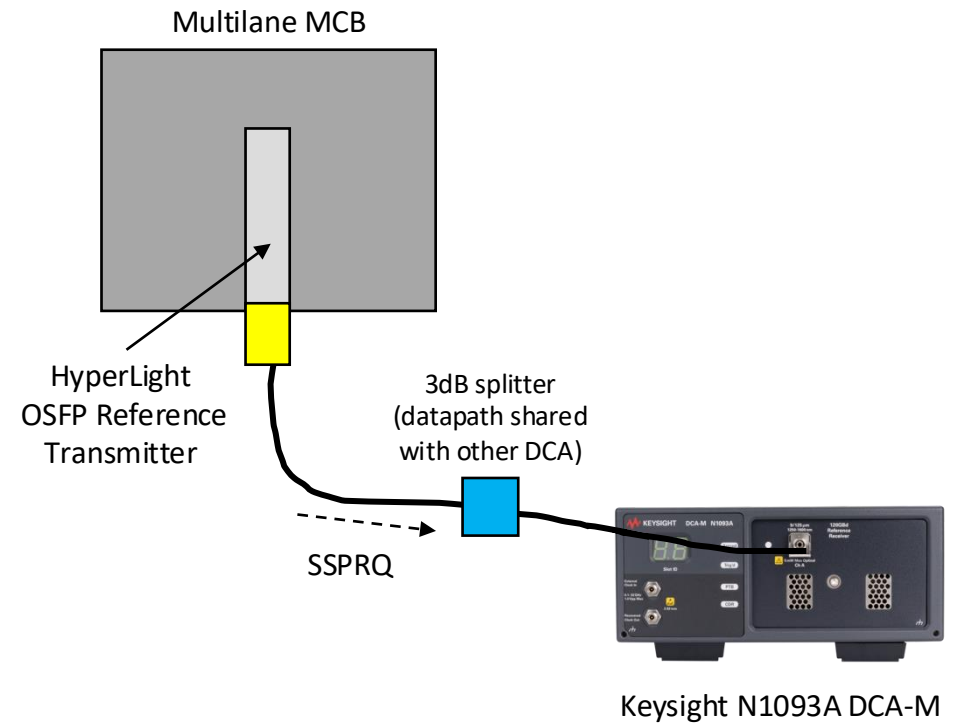

Configuration 1: Target best TECQ

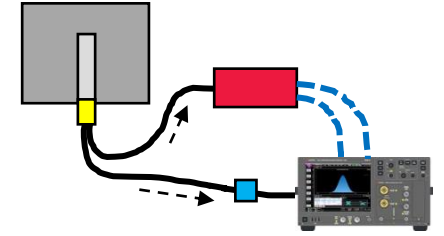

Eye metric	Value
TECQ	0.98 dB
Ceq	-0.15 dB
Outer ER	5.359 dB
Overshoot	14.94%
Undershoot	13.77%
Rise time	4.14 psec
Fall time	4.40 psec
RLM (802.3 CL_94)	0.974
Average power	0.92 dBm
Outer OMA	1.390 dBm

Reference transmitter optimized for lowest TECQ

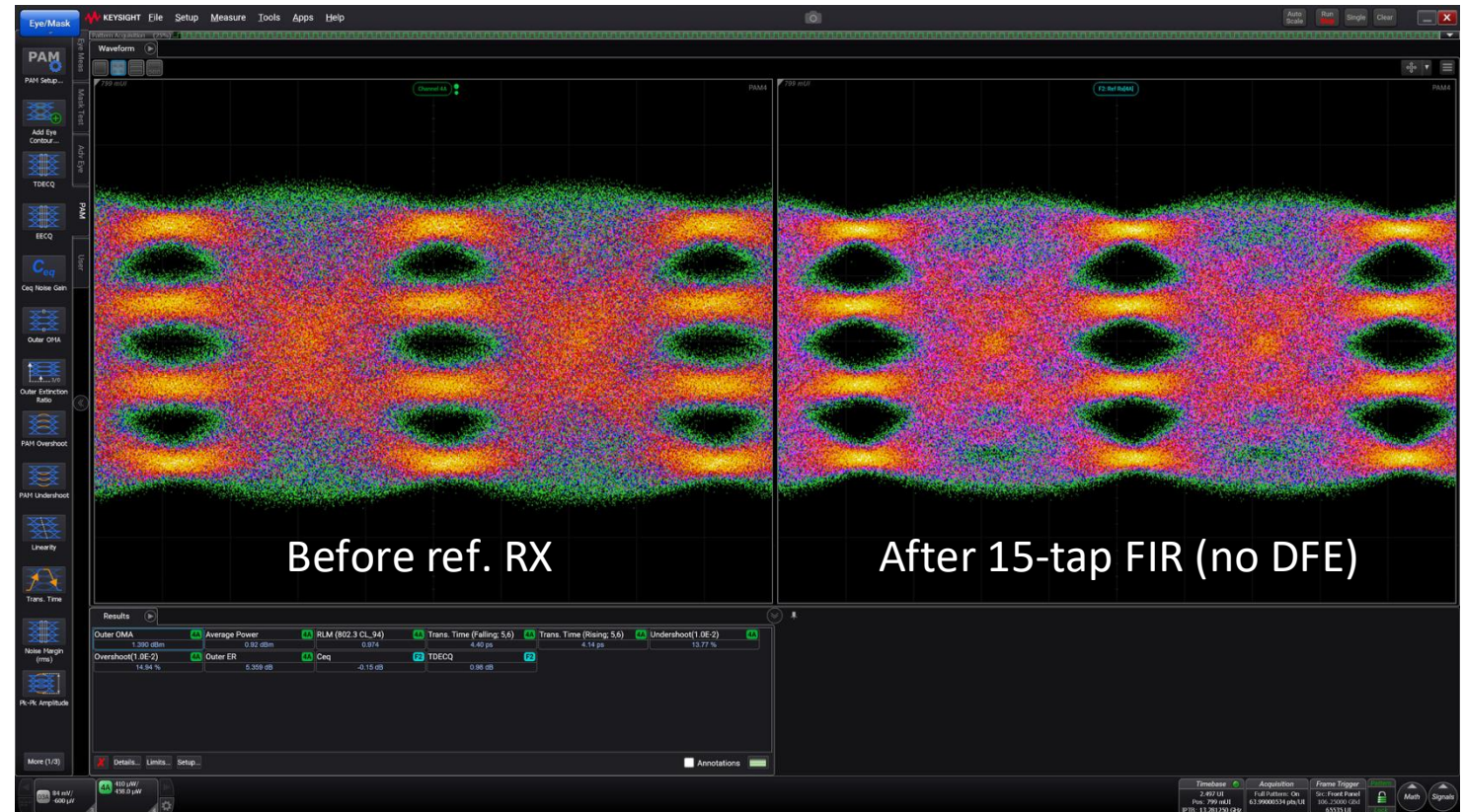

Configuration 1: Target overshoot ~10%

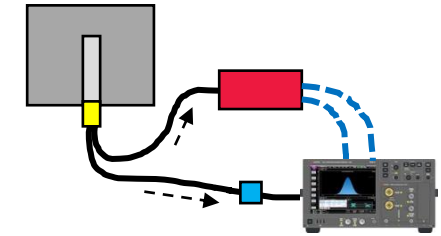

Eye metric	Value
TECQ	1.35 dB
Ceq	0.24 dB
Outer ER	5.221 dB
Overshoot	10.21 %
Undershoot	9.24 %
Rise time	4.58 psec
Fall time	4.62 psec
RLM (802.3 CL_94)	0.986
Average power	1.02 dBm
Outer OMA	1.263 dBm

Reference transmitter optimized for lowest TECQ, with overshoot ~10%

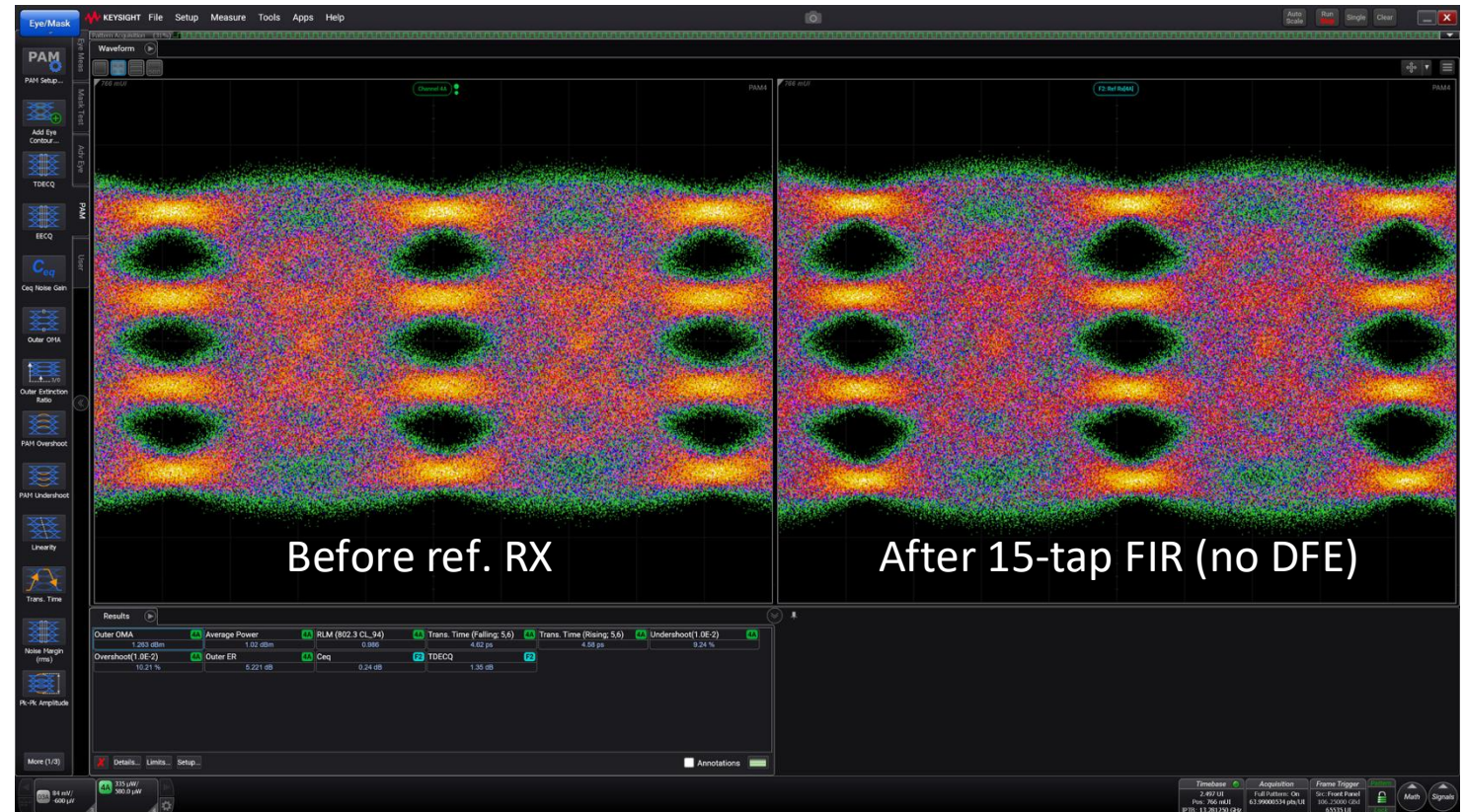

Configuration 1: Data for different Ref. TX EQ settings

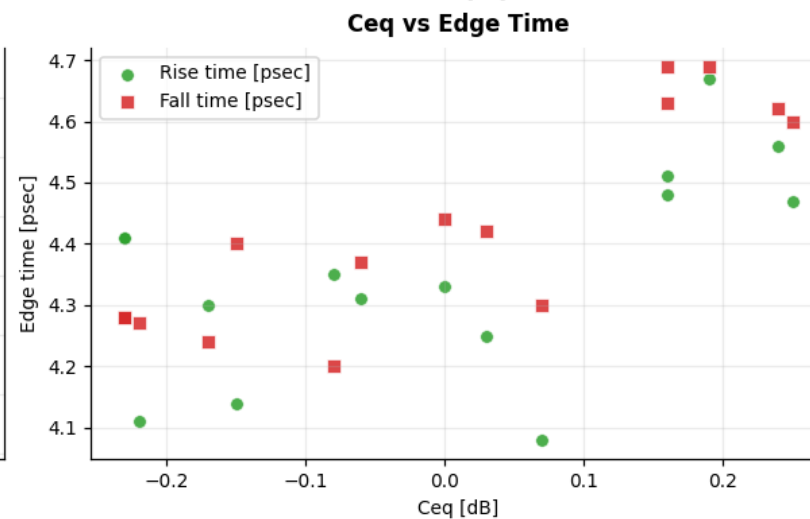
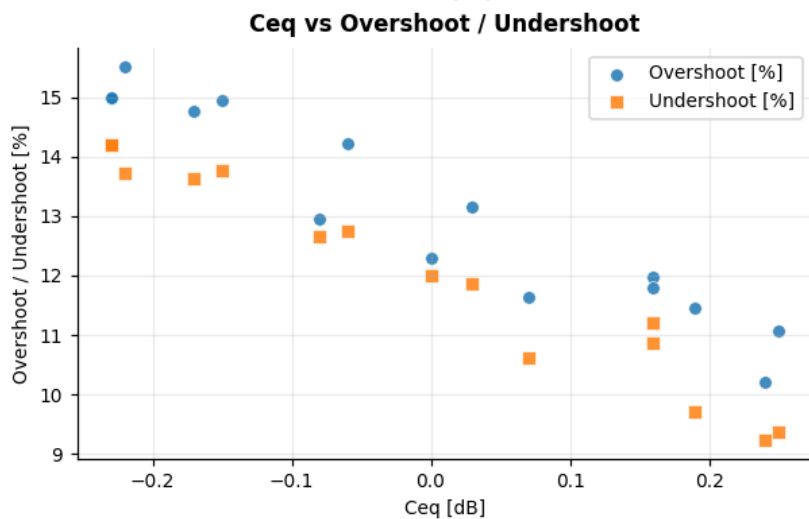
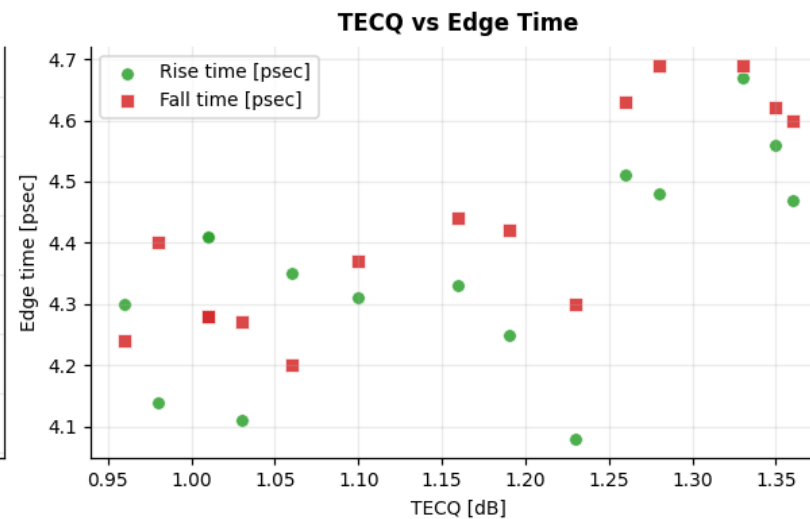
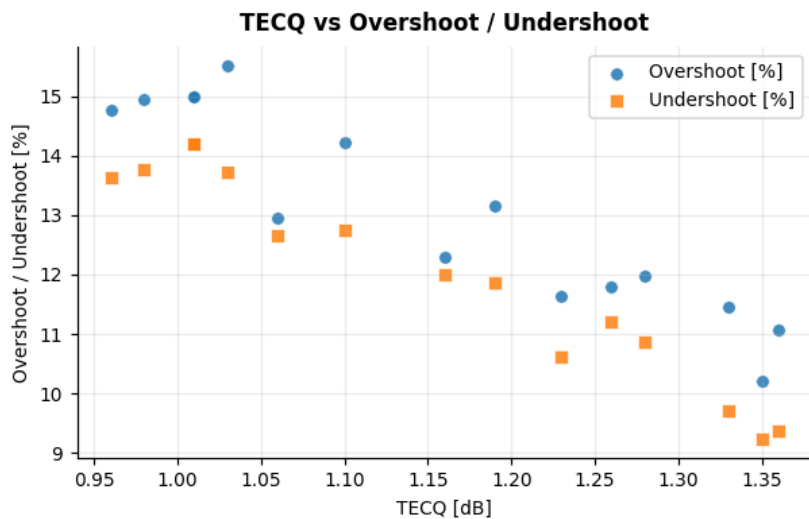
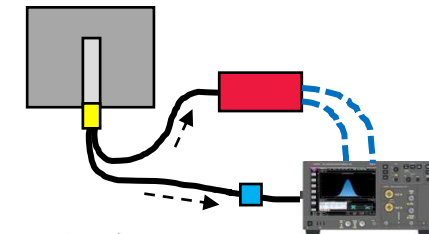

Configuration 2: Target best TECQ

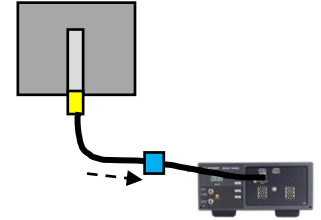

Eye metric	Value
TECQ	1.26 dB
Ceq	0.09 dB
Outer ER	5.053 dB
Overshoot	15.74 %
Undershoot	12.76 %
Rise time	4.54 psec
Fall time	4.63 psec
RLM (802.3 CL_94)	0.982
Average power	0.32 dBm
Outer OMA	0.546 dBm

Reference transmitter optimized for lowest TECQ

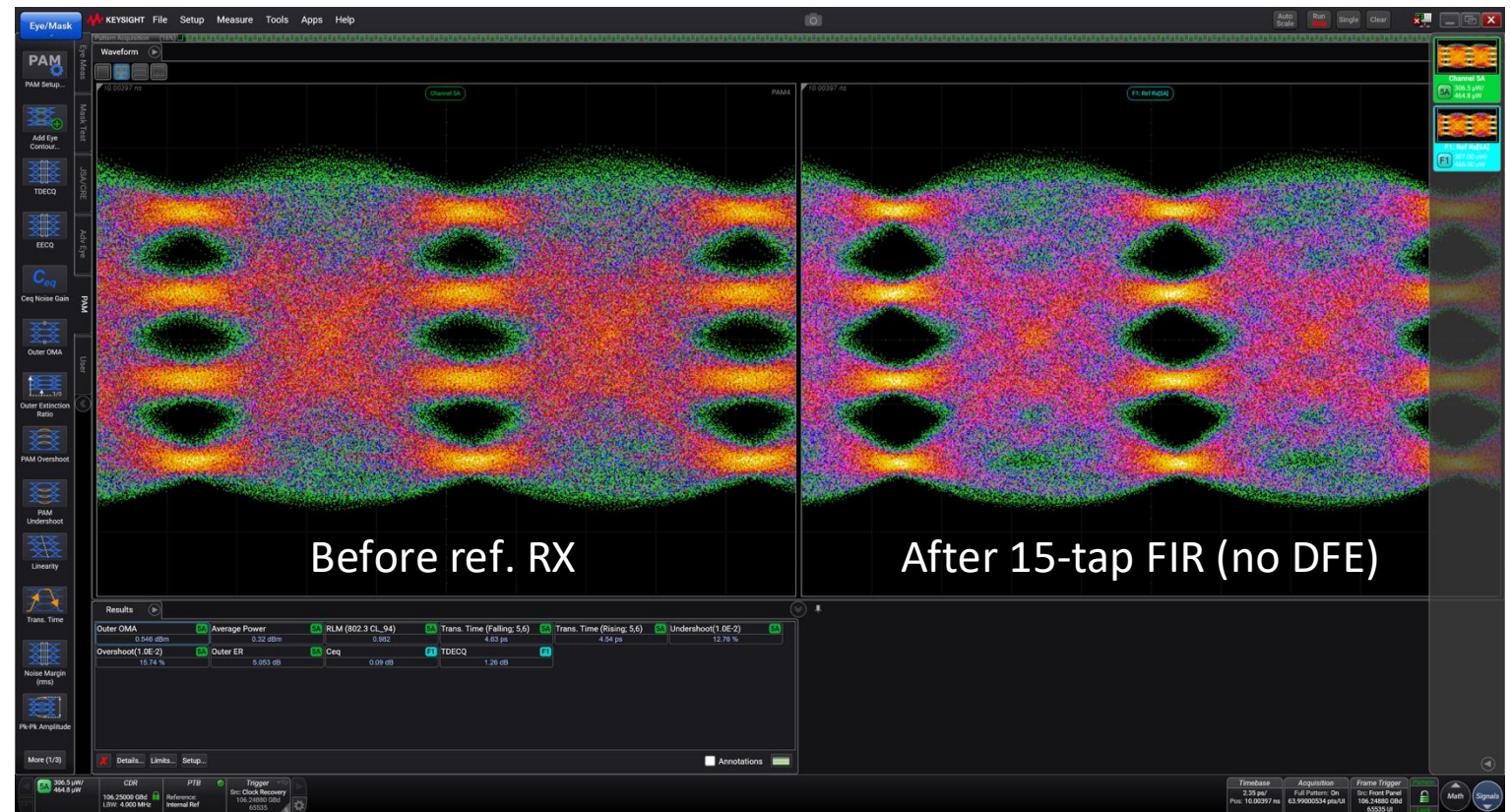

Configuration 2: Target overshoot ~10%

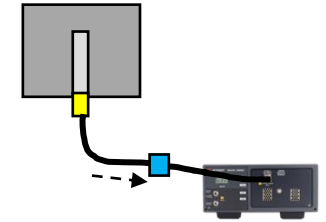

Eye metric	Value
TECQ	1.65 dB
Ceq	0.49 dB
Outer ER	4.937 dB
Overshoot	9.70 %
Undershoot	9.12 %
Rise time	4.98 psec
Fall time	5.20 psec
RLM (802.3 CL_94)	0.983
Average power	0.32 dBm
Outer OMA	0.457 dBm

Reference transmitter optimized for lowest TECQ, with overshoot ~10%

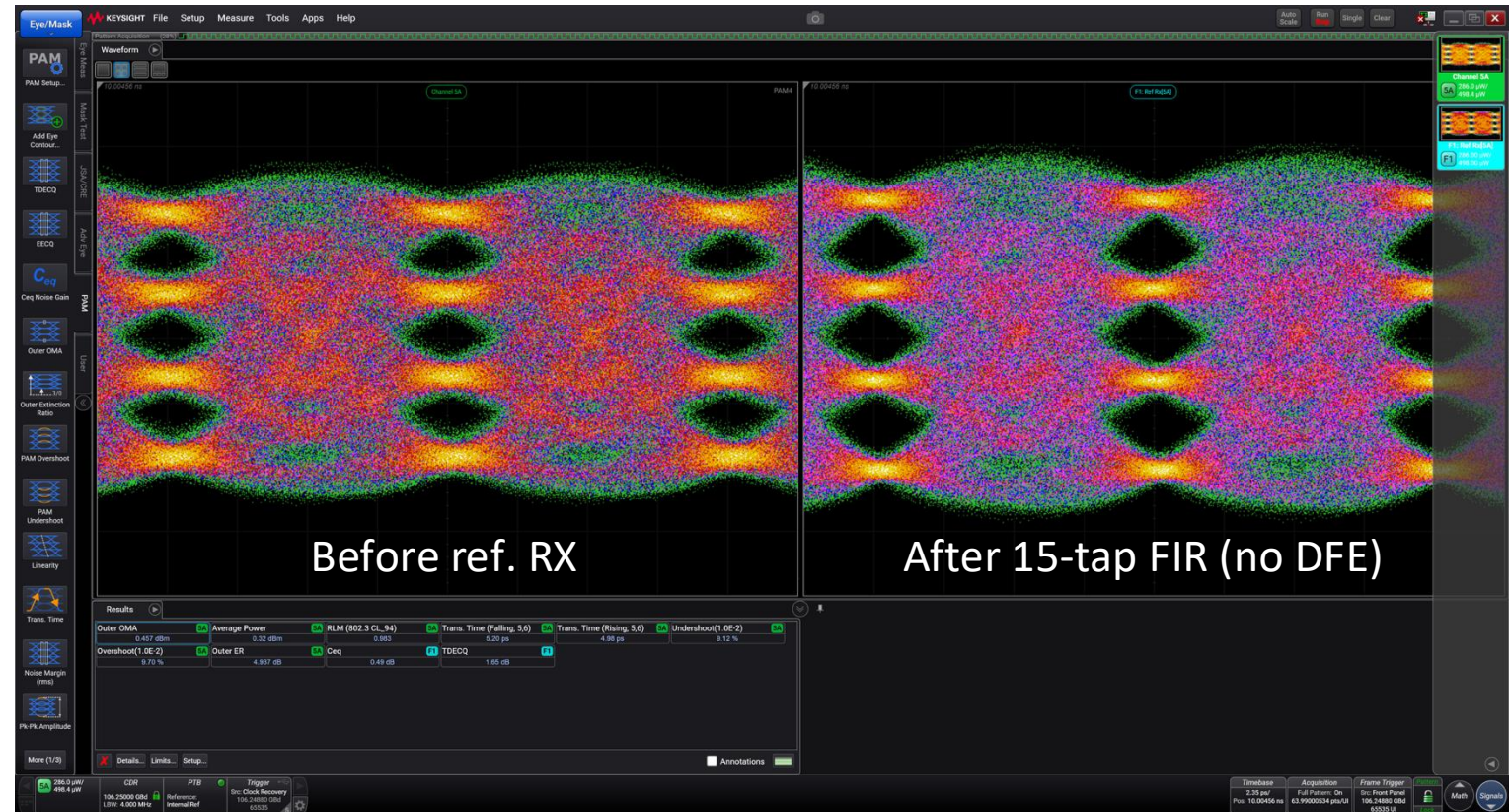

Configuration 2: Data for different Ref. TX EQ settings

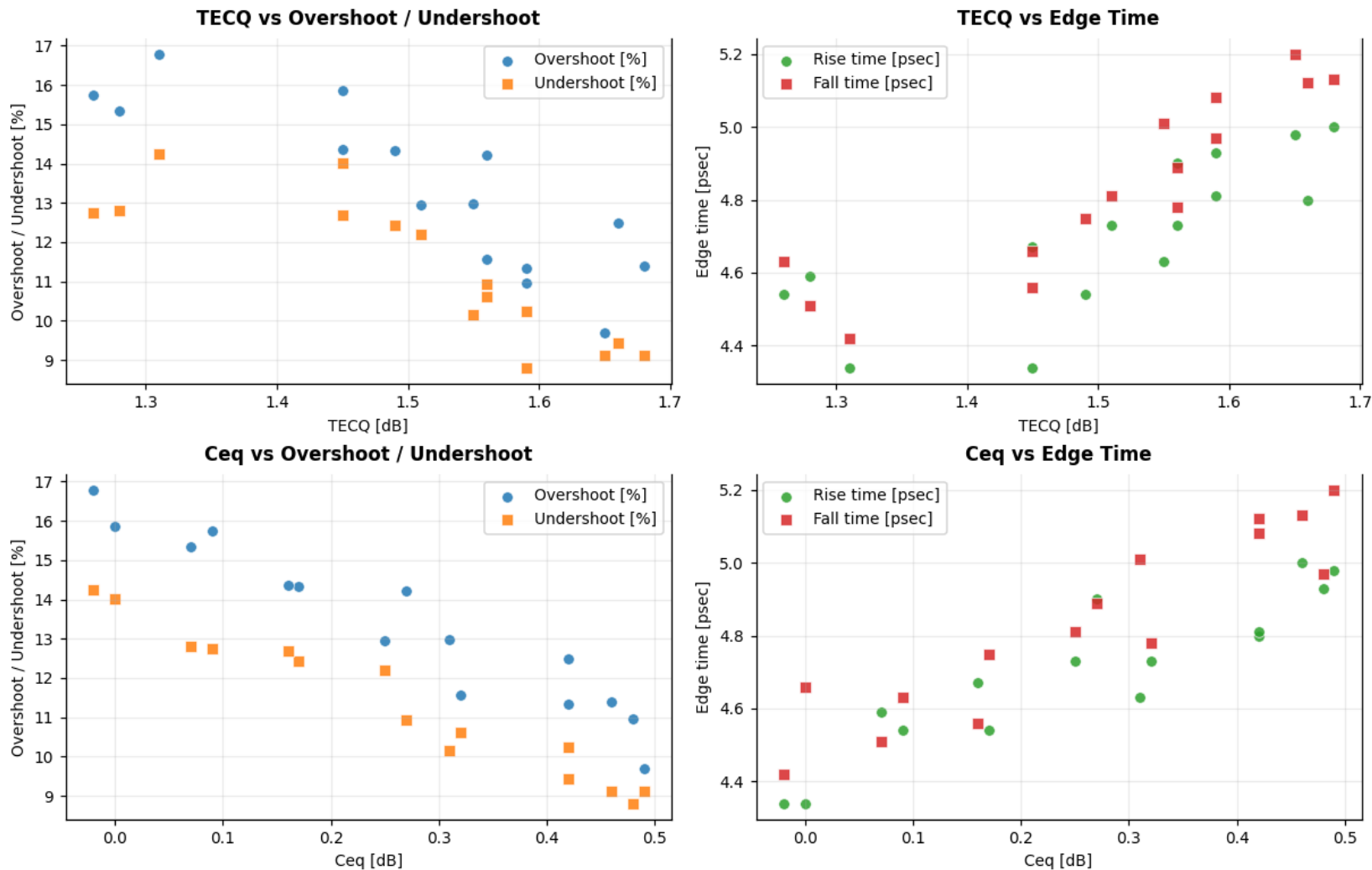
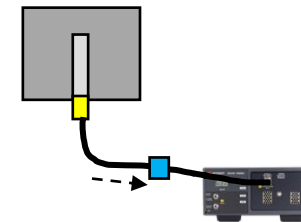

Summary

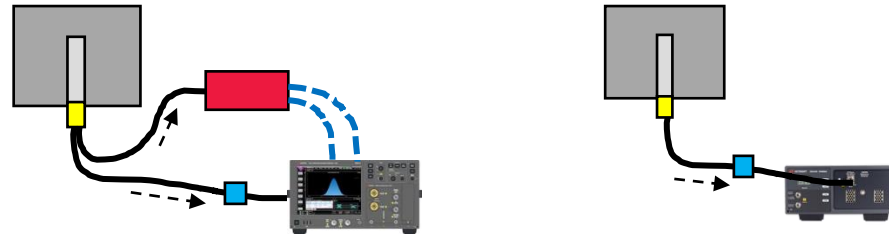

Eye metric	Config. 1 (DCA + external CLK)		Config. 2 (DCA with integrated CRU)	
	Ref. TX (best TECQ)	Ref. TX (target 10% overshoot)	Ref. TX (best TECQ)	Ref. TX (target 10% overshoot)
TECQ	0.98 dB	1.35 dB	1.26 dB	1.65 dB
Ceq	-0.15 dB	0.24 dB	0.09 dB	0.49 dB
Outer ER	5.359 dB	5.221 dB	5.053 dB	4.937 dB
Overshoot	14.94 %	10.21 %	15.74 %	9.70 %
Undershoot	13.77 %	9.24 %	12.76 %	9.12 %
Rise time	4.14 psec	4.58 psec	4.54 psec	4.98 psec
Fall time	4.40 psec	4.62 psec	4.63 psec	5.20 psec
RLM (802.3 CL_94)	0.974	0.986	0.982	0.983
Average power	0.92 dBm	1.02 dBm	0.32 dBm	0.32 dBm
Outer OMA	1.390 dBm	1.263 dBm	0.546 dBm	0.457 dBm