

Equalizer Nomenclature, Description, and Eye Diagram Generation

Norman L. Swenson

Affiliations: Nokia and Point2

Adee Ran

Affiliation: Cisco

Guangcan Mi

Affiliation: Huawei

Roberto Rodes

Affiliation: Coherent

Mike Dudek

Affiliation: Marvell

Version 1.1c

IEEE 802.3dj May Meeting

5 May 2026

Comments Addressed: I-180, I-224, I-391, I-393, I-396, I-463

Supporters

- Chris Cole, Coherent

Preview

- This presentation suggest changes to the draft specification that address
 - Equalizer Nomenclature
 - Generation of the eye diagram
 - Synchronization of the test pattern with the input to the equalizer
 - Location of the histograms
- The goal was to remove ambiguity with minimal changes to the existing text

Proposed Changes to p.479

The reference equalizer is a T-spaced discrete-time equalizer with 15 feedforward taps and a single decision feedback tap, where T is the symbol period. Equalizer coefficient constraints are given in Table 180-16. The reference equalizer may be implemented in the oscilloscope. The decisions fed back in the equalizer are modeled as being correct, so the equalizer is modeled as shown in Figure 180-10, where $x(n)$ is the n^{th} symbol in the test pattern sequence, $r(t)$ is the output of the reference receiver defined in 180.9.2, $\eta(t)$ is colored Gaussian noise, $z(t) = r(t) + \eta(t)$, $z_n = z(nT + \phi)$, where $0 \leq \phi < T$, and y_n is the equalizer output corresponding to $x(n)$. The Bessel-Thomson (BT) filter shown is identical to that in 180.9.2. The received signal $r(t)$ is aligned with the test pattern such that $r(nT)$ corresponds to $x(n)$.

180.9.6.3 Reference equalizer

The reference equalizer is a 15-tap, T-spaced, feed-forward equalizer (EFE), followed by a 1-tap decision feedback equalizer (DFE), where T is the symbol period, with equalizer coefficient constraints as shown in Table 180-16. The reference equalizer may be implemented in the oscilloscope.

NOTE—This reference equalizer is part of the test and does not imply any particular receiver equalizer implementation.

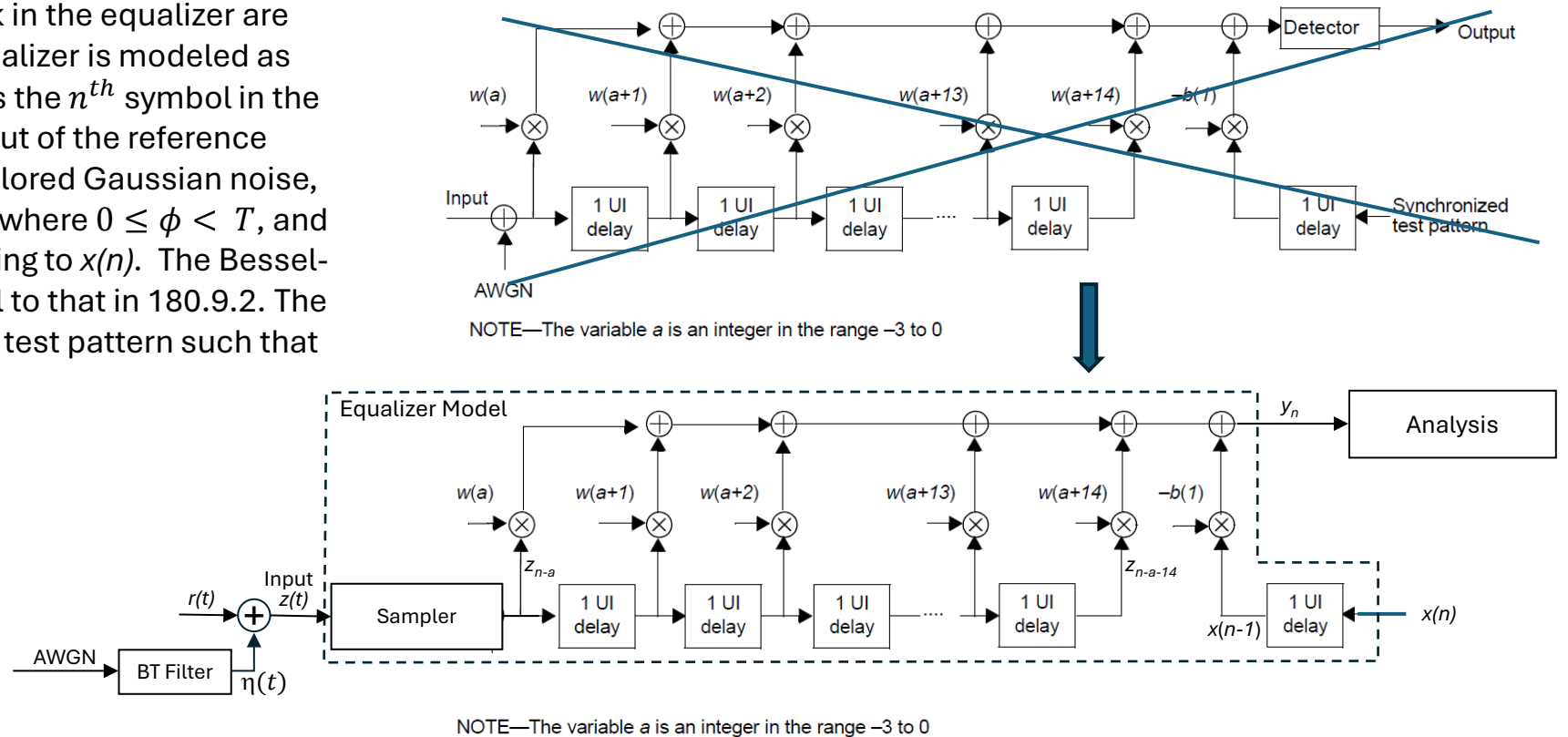

Proposed Changes to Table 180-16

Table 180-16—Reference equalizer tap coefficients

Number of feedforward taps ←

Parameter	Symbol	Value	
		Minimum	Maximum
Feed forward equalizer (FFE) length	N_w	15	
Number of equalizer pre-cursor taps	—	0	3
Main tap coefficient limit	$w(0)$	0.8	2.5

Number of feedback taps ←

Parameter	Symbol	Value	
		Minimum	Maximum
Normalized equalizer coefficient limits:	$w(i)/w(0)$		
$i = -3$		-0.15	0.1
$i = -2$		-0.1	0.25
$i = -1$		-0.5	0.1
$i = 1$		-0.6	0.2
$i = 2$		-0.2	0.3
$i = 3$		-0.15	0.15
$i = 4$		-0.15	0.15
$i = 5$		-0.15	0.15
$i = 6$		-0.15	0.15
$i \geq 7$		-0.1	0.1
Pre-post equalizer coefficient difference limit: $ w(1)/w(0) - b(1) - w(-1)/w(0) $	—	—	0.25
Equalizer DC gain ^a	—	1	
Decision feedback equalizer (DFE) length	N_b	1	
DFE coefficient limit ^b	$b(1)$	0	0.3

^a The sum of all 15 equalizer coefficients, $w(i)$.

^b The DFE coefficient $b(1)$ is referenced to $OMA_{outer}/2$ measured at the input of the FFE equalizer.

Proposed changes to p.480

180.9.6.4 TDECQ measurement method

The standard deviation of the noise of the reference receiver specified in 180.9.2, σ_S , is determined with no optical input signal and the same settings as used to capture the histograms described below.

The test pattern specified for TDECQ (see Table 180-13) is transmitted repetitively by the optical lane under test and the oscilloscope is set up to capture samples from all symbols in the complete pattern without averaging.

If an equivalent-time sampling oscilloscope is used, the impact of the sampling process and the reference equalizer on transmitter noise has to be compensated for, so that the correct magnitude of noise is present at the output of the equalizer.

The captured waveform is processed to find the largest noise that could be combined with the signal by a reference receiver when optimally equalized by a reference equalizer. The optimal equalizer tap coefficients are dependent on the amount of noise that can be added to the signal, so finding the noise that can be added and the optimal equalizer setting is an iterative process. One way of doing this, using estimated PAM4 symbol error ratio as the figure of merit for the equalized signal, is described below.

The reference equalizer specified in 180.9.6.3 is applied to the waveform. An eye diagram is formed from the equalized captured waveform.

~~The average optical power (P_{ave}) of the equalized eye diagram is determined, and the 0 UI and 1 UI crossing points are determined by the average of the eye diagram crossing times, as measured at P_{ave} , as illustrated in Figure 180-11.~~

as follows. For a given sampling phase ϕ_0 , optimize the equalizer coefficients $\mathbf{w} = [w(a) w(a + 1) \dots w(a + 14)]$ and b . With the coefficients fixed, sweep the sampling phase from $\phi_0 - \frac{T}{2}$ to $\phi_0 + \frac{T}{2}$, and for each phase plot the scatter plot of the y_n values resulting from the test pattern sequence. An example eye diagram is shown in Figure 180-11. The feedback symbol $x(n)$ changes at phase $\phi = \phi_0 - \frac{T}{2}$. Note: the Gaussian noise $\eta(t)$ added to $r(t)$ in Figure 180-10 is not reflected in the eye diagram; it is accounted for separately when estimating the SER in the analysis block.

Proposed changes to p. 481

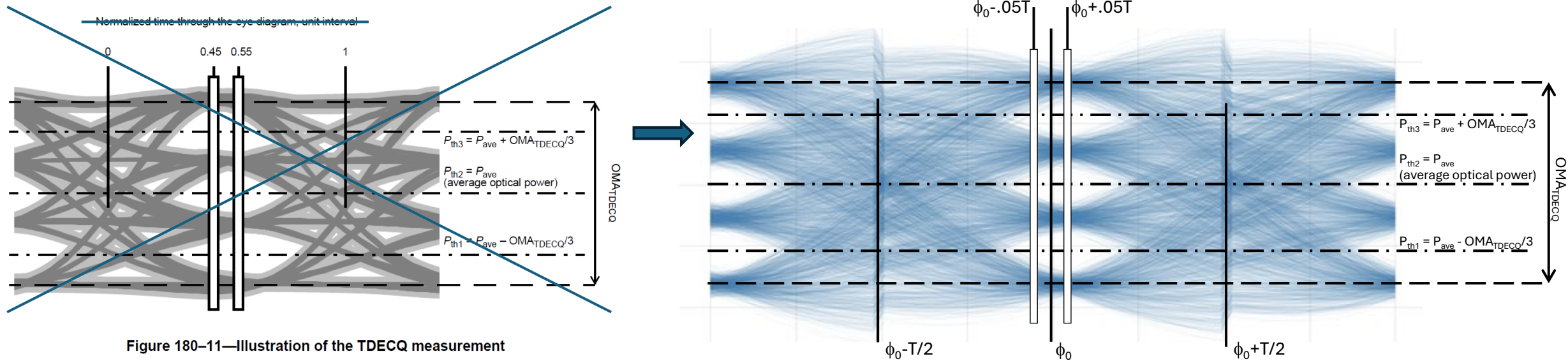

Figure 180-11—Illustration of the TDECQ measurement

Two vertical histograms are measured through the eye diagram, nominally centered at ~~0.45 UI and 0.55 UI~~ \rightarrow $\phi_0 - 0.05T$ and $\phi_0 + 0.05T$. Each of the histogram windows spans all of the modulation levels of the eye diagram, as illustrated in Figure 180-11. The precise time position of the pair of histograms is adjusted to minimize TDECQ while keeping the histograms spaced 0.1 UI apart.

Thank You

Backup (Presented Earlier)

Background of Reference Equalizer for TP2 Compliance Testing

- The first reference equalizer for 802.3 compliance testing was TWDP (Transmitter Waveform and Dispersion Penalty) in Clause 68.6.6 for 10GBASE LRM
 - December 2004 contribution by Swenson, Voois, Lindsay, and Zeng
 - <https://grouper.ieee.org/groups/802/3/aq/public/tools/>
 - N. Swenson, et al., "Explanation of IEEE 802.3, Clause 68 TWDP," 2006, available as Clause_68_TWDP.pdf at https://standards.ieee.org/wp-content/uploads/2022/07/802.3-2022_downloads.zip
 - N. L. Swenson, et al., "Standards Compliance Testing of Optical Transmitters Using a Software-Based Equalizing Reference Receiver," in *OFC and NFOEC*, 2007, paper NWC3. <https://opg.optica.org/abstract.cfm?URI=NFOEC-2007-NWC3>
 - The final version of the TWDP reference equalizer was a T/2-spaced DFE with 14 feedforward taps and 5 feedback taps
- TDEC was subsequently introduced for binary NRZ waveforms using a T-spaced FFE reference equalizer
- TDECQ followed for PAM-4, also based on a feed forward equalizer

Explaining the Eye Diagram

Comment I-463 (Dawe), I-180 (Healy), I-393 (Swenson), I-224(Maniloff)

Suggested resolution: Propose a wording that is mutually acceptable to these commenters.

Comments I-394 (Swenson), I-396 (Swenson)

Suggested remedy: Delete the eye diagram. Or if we keep it, add the “bat-wings”.

What is the origin of the eye diagram?

- A discrete-time equalizer has no eye diagram
 - A discrete-time signal is not defined in between samples
- Or you could say it has a “boring” eye diagram if you maintain that the signal stays constant between samples

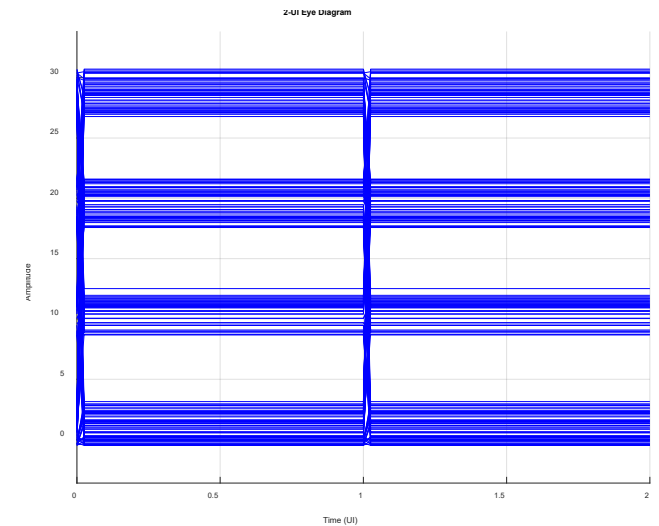
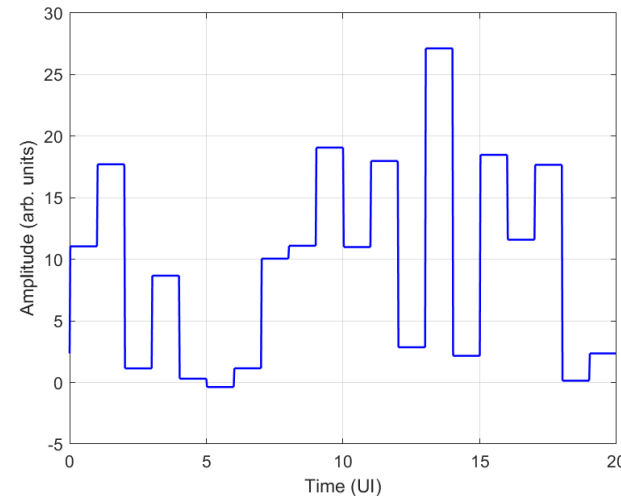
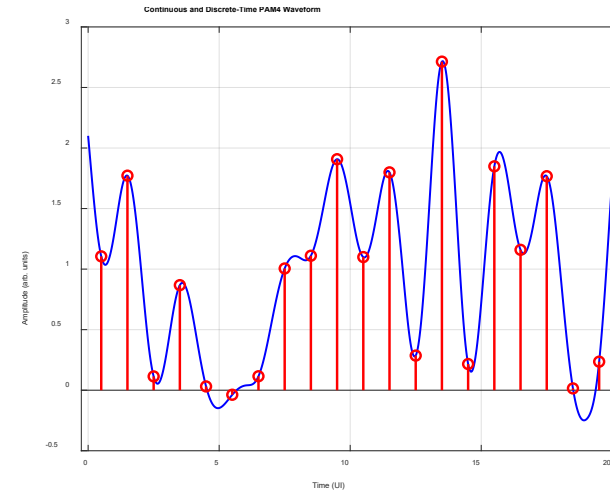

Two Options

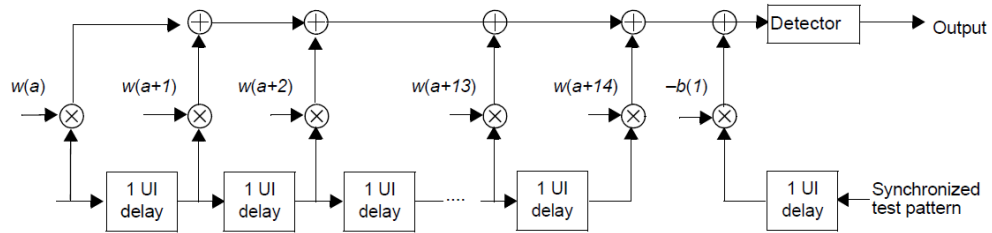

NOTE—The variable a is an integer in the range -3 to 0

Figure 180–10—TDECQ reference equalizer functional model

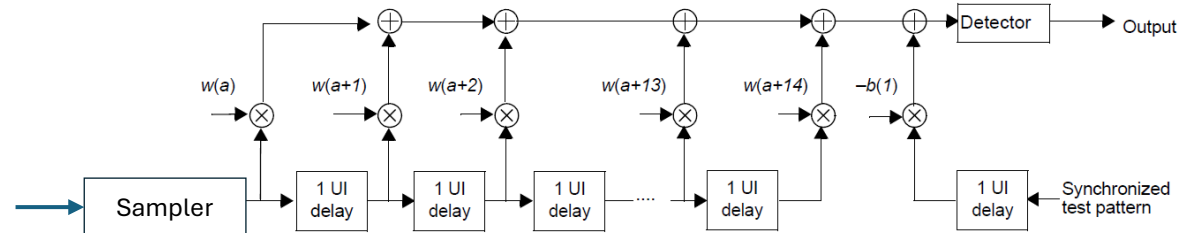

NOTE—The variable a is an integer in the range -3 to 0

Figure 180–10—TDECQ reference equalizer functional model

- 1) Continuous time equalizer

- Taps are adjusted based on 1UI - spaced samples
- Components shown are ideal (infinite bandwidth)

- 2) Discrete time equalizer

- 1UI –spaced Sampler is at the input
- For a given tap setting, the phase of the sampler can be swept to produce the eye diagram

The DFE Eye Diagram

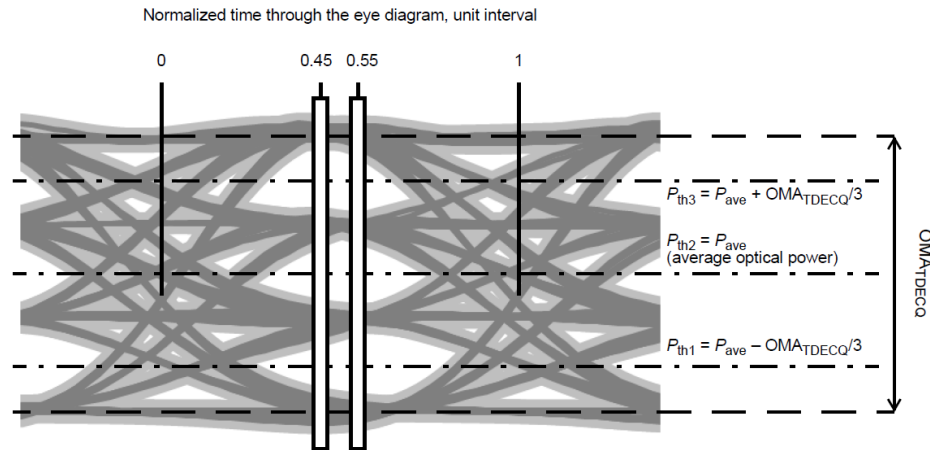
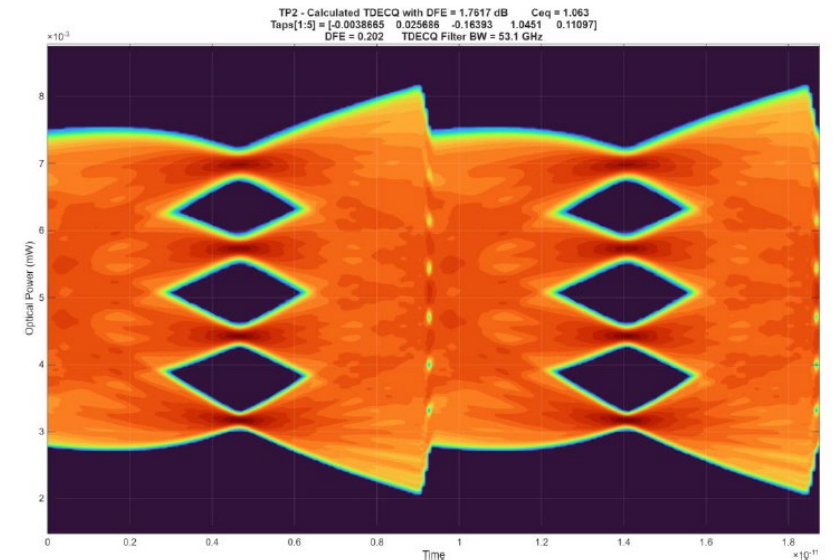

Figure 180-11—Illustration of the TDECQ measurement



Eye diagram courtesy Mark Kimber, Semtech

- However we define it, we need to include the “bat-wing” if we show the eye diagram
 - This is a unique feature of the DFE eye diagram. The amount added to the waveform is constant over 1UI.
- Timing: The value must change outside of the two histogram windows
 - Nominally $\frac{1}{2}$ UI from the center eye opening is a good choice
 - We need to say something about this in the text
 - Perhaps “1/2 UI from the nominal point at which the TDECQ is measured”
 - This needs better description in the text and figure

Nomenclature

Comments I-391 (Swenson), I-224 (Maniloff)

Suggested resolution: Some mutually acceptable combination of the two suggested remedies.

Nomenclature

- The D3.0 TDECQ reference equalizer is a T-spaced DFE with 15 feedforward taps and 1 feedback tap
 - It is not an FFE followed by a DFE
 - It is a single equalizer with the taps jointly optimized. If it were two separate equalizers, the taps for each would be independently optimized.
 - The feedforward (FF) section of the DFE serves a different role than that of a standalone FFE
 - FFE attempts to minimize ISI
 - FF section of DFE attempts to minimize *pre-cursor* ISI, leaving post-cursor ISI for the feedback section to handle
- The terminology proposed here is supported in:
 - Reference textbooks
 - Peer-reviewed literature
 - Industry
 - IEEE 802.3, Clause 68

Textbook Definition

- John G. Proakis and M. Salehi, *Digital Communications*, 5th ed. 2008, p.661
 - “The nonlinear equalizer consists of two filters, a feedforward filter and a feedback filter, arranged as shown in Figure 9.5-1, called a *decision-feedback equalizer (DFE)*.”

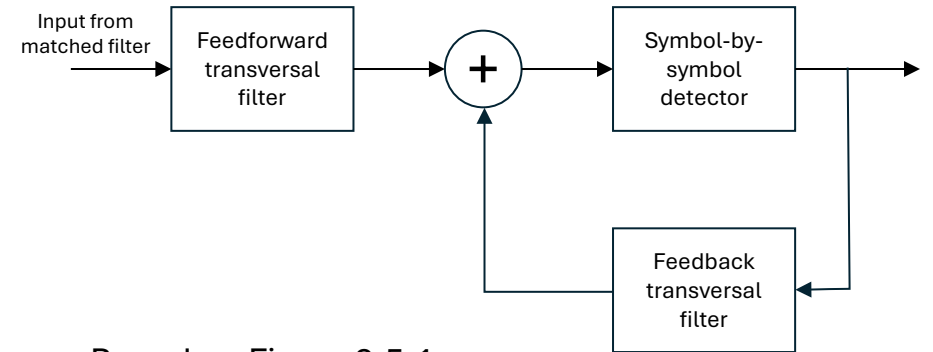

Based on Figure 9.5.1
Structure of decision-feedback equalizer

- E. A. Lee and D. G. Messerschmitt, *Digital communication*, 2nd ed., 1994, p.541.

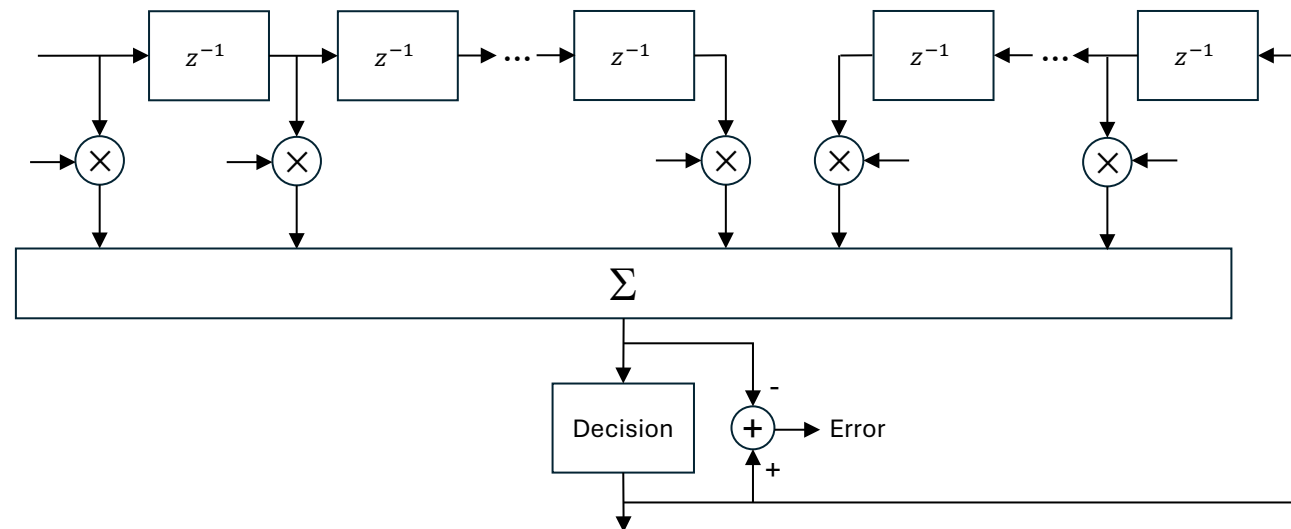

Based on Figure 11-10:
The DFE for finite precursor and postcursor equalizer transversal filters.

Literature Definition

M. E. Austin, "Decision-feedback equalization for digital communication over dispersive channels," MIT Lincoln Lab., p. 102, 1967, [Online]. Available: <http://dspace.mit.edu/handle/1721.1/4282>

M.E. Austin invented the DFE, described in this 1967 report.

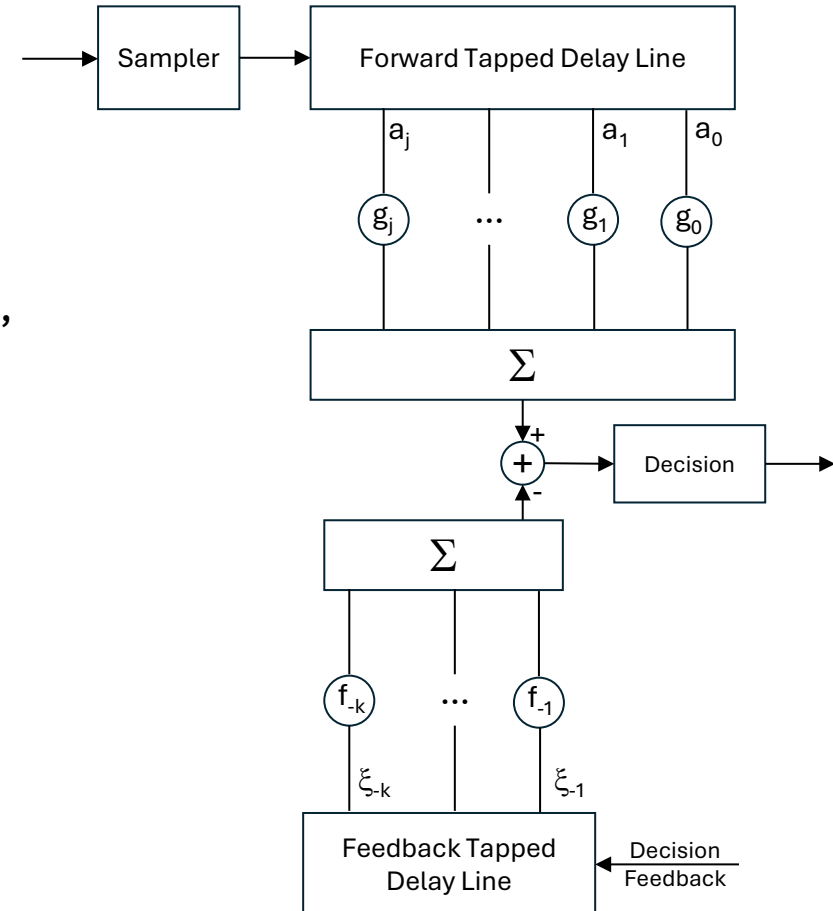

Based on Fig. 9.
Structure of decision-feedback equalizer.

Industry Definition

MATLAB & Simulink, Communications Toolbox User Guide

- p. 14-7: “A DFE ... contains a forward filter and a feedback filter. The forward filter is similar to a linear equalizer. The feedback filter contains a tapped delay line whose inputs are the decisions made on the equalized signal.”
- p. 15-12: Gives an example of a DFE equalizing a BPSK modulated signal “specifying a decision feedback LMS equalizer having eight forward taps [and] five feedback taps”

IEEE 802.3 Definition

- Clause 68.6.1
 - “The reference equalizer is a decision feedback equalizer with defined tap number and spacing, as specified in 68.6.6.2.”
- Clause 68.6.2
 - “14 T/2-spaced feedforward equalizer taps; 5 T-spaced feedback equalizer taps”
- Please see these contributions to 802.3aq for 10GBASE-LRM, as pointed out by Chris Cole:
 - https://grouper.ieee.org/groups/802/3/10GMMFSG/public/jan04/bhoja_2_0104.pdf#page=8
 - https://grouper.ieee.org/groups/802/3/10GMMFSG/public/jan04/baek_1_0104.pdf#page=5
 - https://grouper.ieee.org/groups/802/3/10GMMFSG/public/mar04/swenson_1_0304.pdf#page=13
- Nowhere in 802.3 is a DFE consisting of a feedforward filter and a feedback filter referred to as “an FFE followed by a DFE”. In particular, clause 168 does not use that terminology.