

Measurements on PoC Noise and Coupling

HEIKO STROHMEIER,

AFFILIATION(S): ROBERT BOSCH GMBH

Contributors

Dominik Brödel (Robert Bosch GmbH)

Nikolai Ostroushko (Robert Bosch GmbH)

Presentations considered

- Measurements and Simulations on MDI Return Loss including PoC/PoDL (Heiko Strohmeier)
 - PMIC input impedance was unknown.
- Combined PSE and PD Injected PoC Noise Limit for IEEE 802.3dm (Sujan Pandey)
 - NBI (Narrowband Interference) and absolute noise levels.
- 802.3 Powering & MPoE (George Zimmerman)
 - Discusses PMIC noise and measurement points.

Motivation

- Initial approach: Simulated the PMIC-to-PHY noise transfer function on the camera node to estimate expected noise coupling.
- Key limitation: Results are highly sensitive to the dynamic input impedance of the active DC/DC converter, making static simulations unreliable.

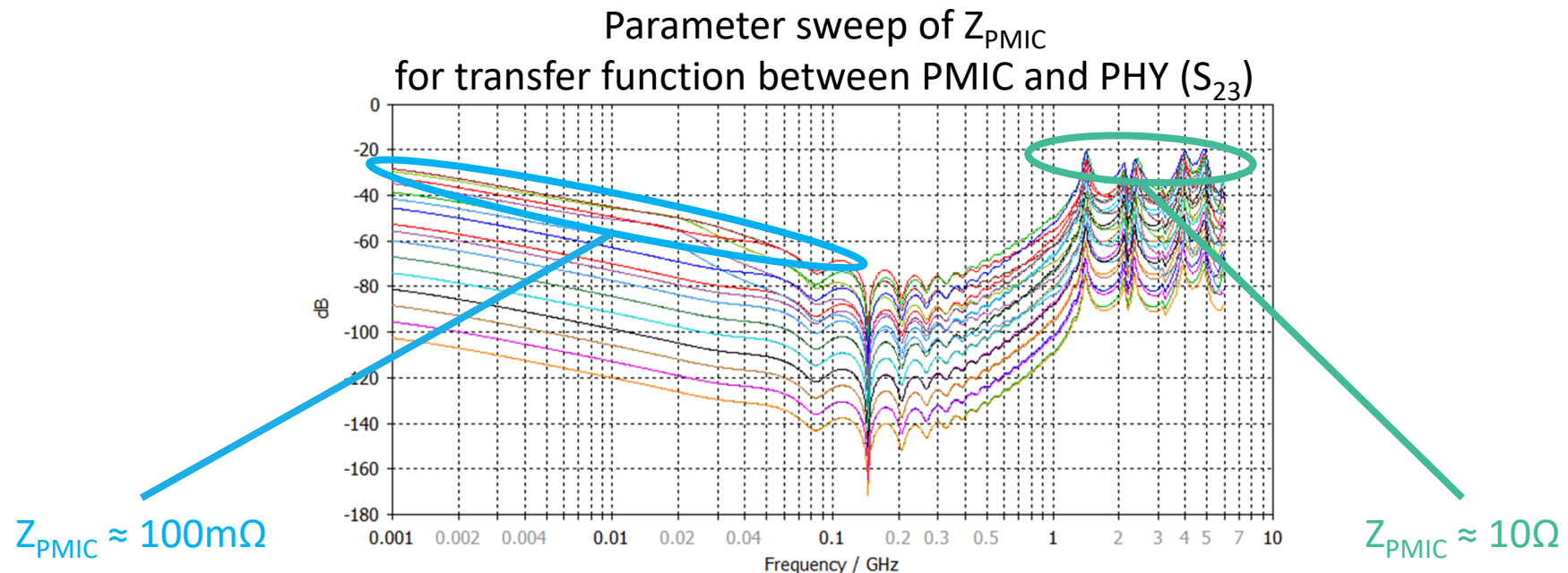

Measurement Setup – Powered Device

- Active transfer function of the 2.2 μH PoC inductor measured via spectrum analyzer and custom transmission line probes.
- Captured under real-world conditions (camera supplied, 2.3 MHz spread-spectrum PMIC with 2W load)
- No load jumps, no active communication on MDI
- Custom Probe Characteristics:
 - Single probe attenuation: 1:21 ($\approx 26.4\text{dB}$)
 - Bandwidth: $\approx 50\text{kHz} - 300\text{ MHz}$

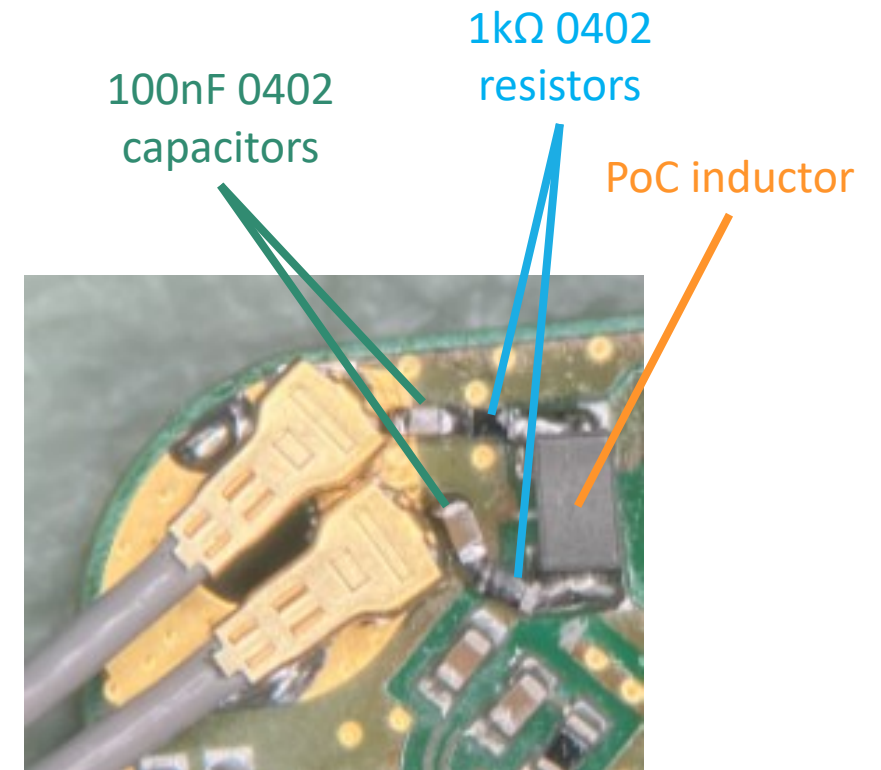
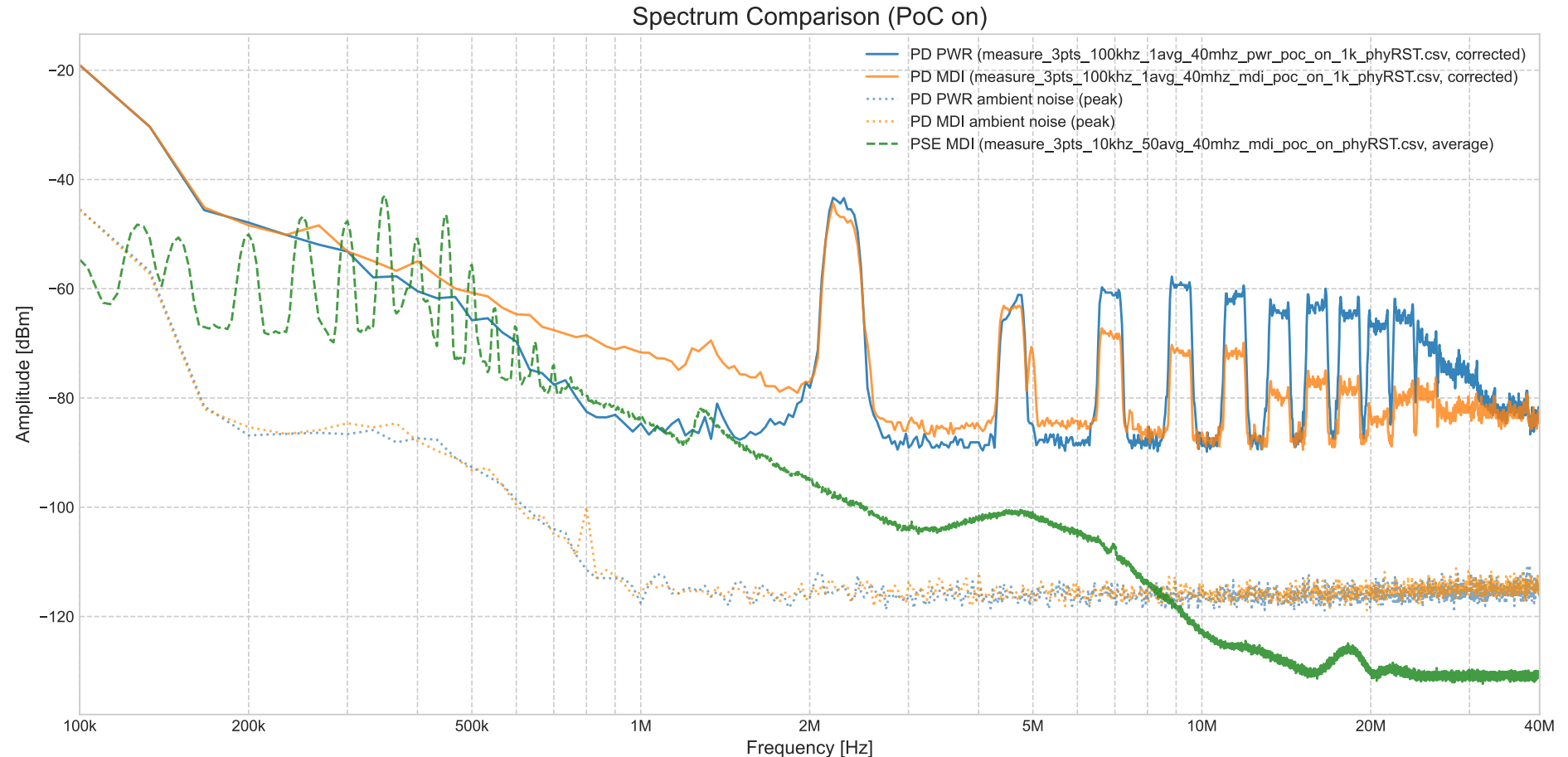

Photo of transmission line probe

Spectrum-Analyzer Results – Powered Device

- Spread-spectrum clock requires long capture time and peak values
- RBW = 100 kHz
- PSE is very noisy, not representative (also average, not peak)



Estimated Transfer Function of PWR → MDI

- Due to passive measurement, transfer function is only valid where measured noise is above noise floor.
- 2.2 μH inductor transfer function also depends on source/sink impedance.

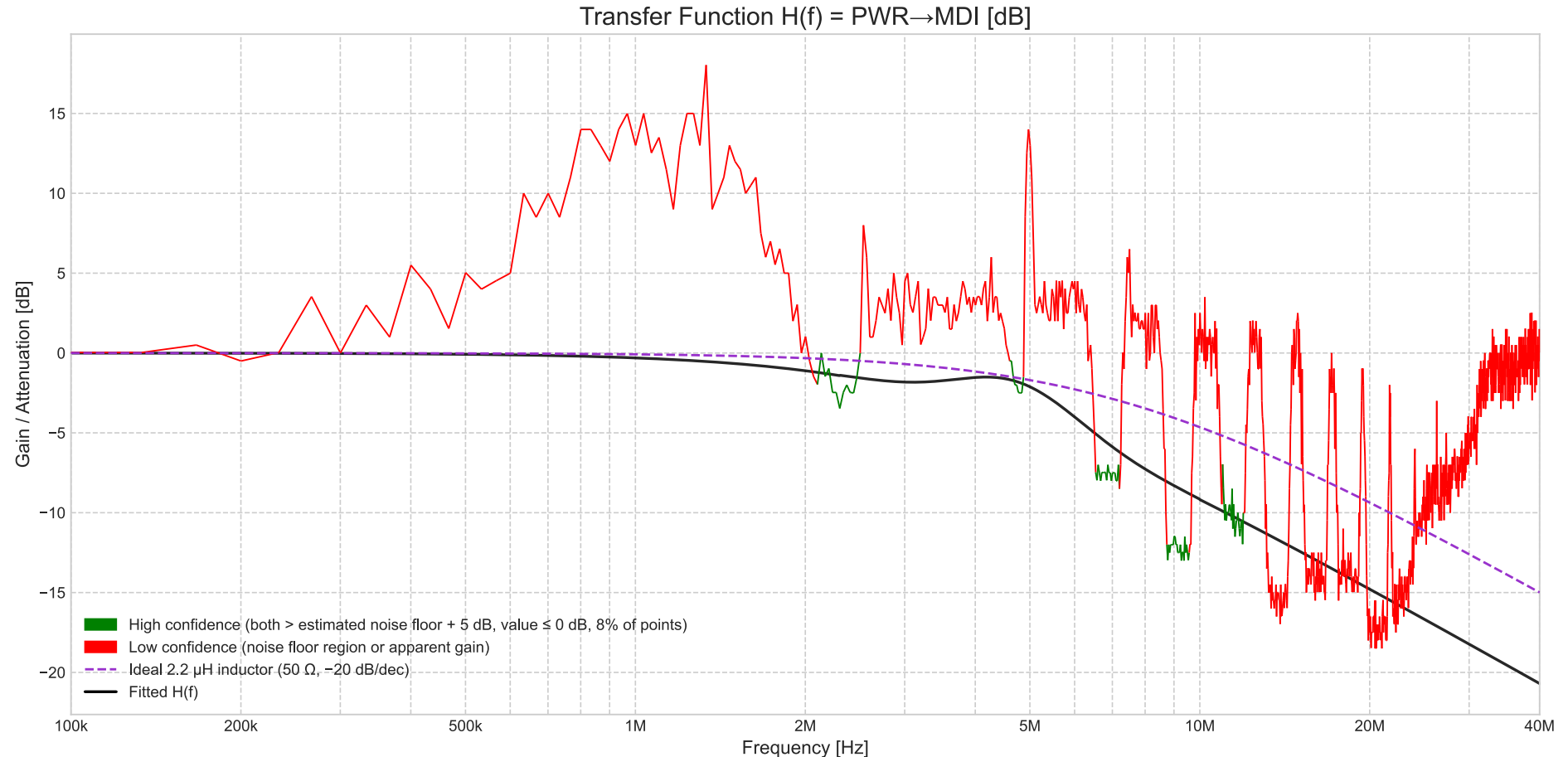

How to measure? Power Sourcing Equipment

- Advantage: Self-supplied PSE architecture simplifies direct in-line noise measurement.
- Relevant for testing is only Port 1 (with external DC protection).
- But local PHY of PSE will also see additional noise from PD side.

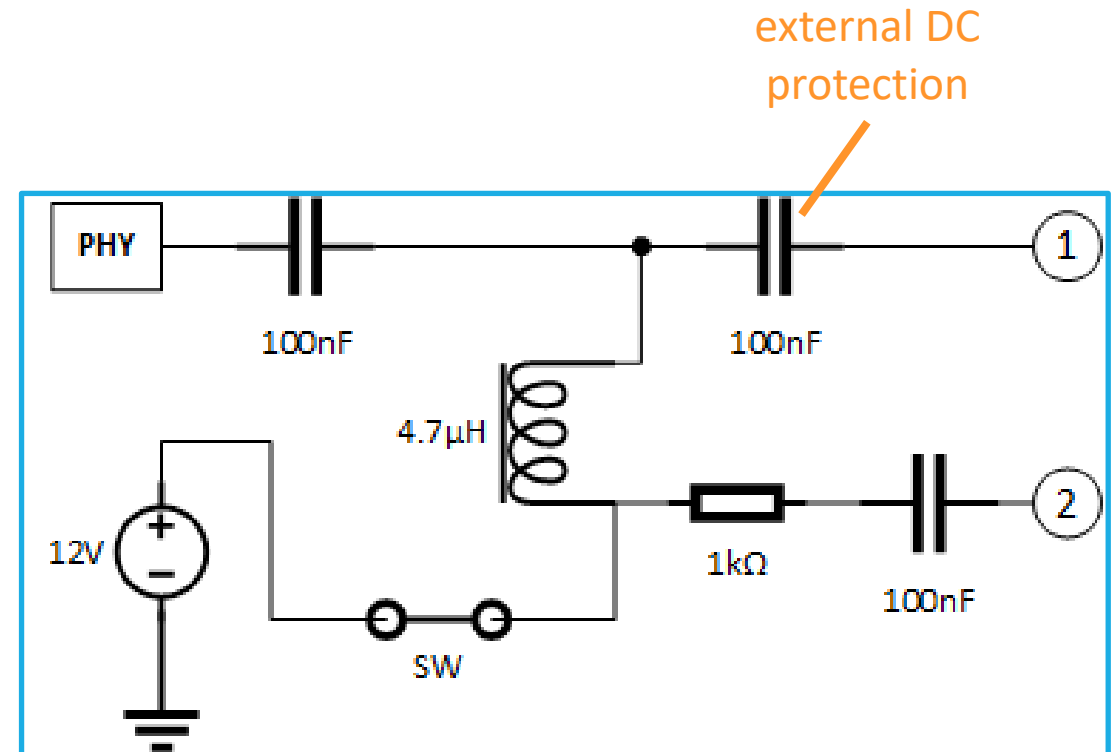

Simplified Schematic of Measurement Setup for Coax channel

How to measure? Powered Device

- Disadvantage: PD must be supplied on MDI (preferably via a PSE with realistic output impedance).
- Differential Probe + Oscilloscope could be used to estimate noise level at PHY (as in Clause 104.5.7.4), should be high-impedance ($> 1\text{k}\Omega$) and resolution should be sub-millivolt.
- Local PHY of PSE will also see additional noise from PD side.

Noise in Time Domain at PMIC

- -47 dBm (peak at 2.3 MHz) $\approx 1 \text{ mV}_{\text{RMS}}$
- The peak-to-peak voltage can only be estimated as worst for the spectrum and the true value must be measured in time domain.

Measurement setup adjustments:

- Bypassed 1k Ω resistor.
- Measurement with 30 MHz LPF.

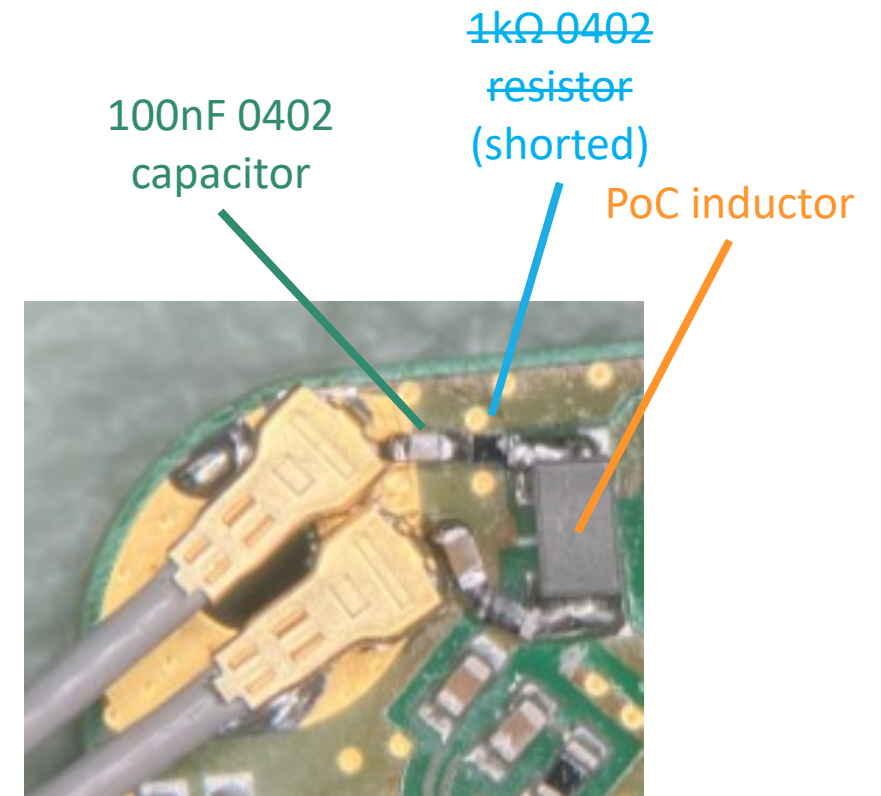
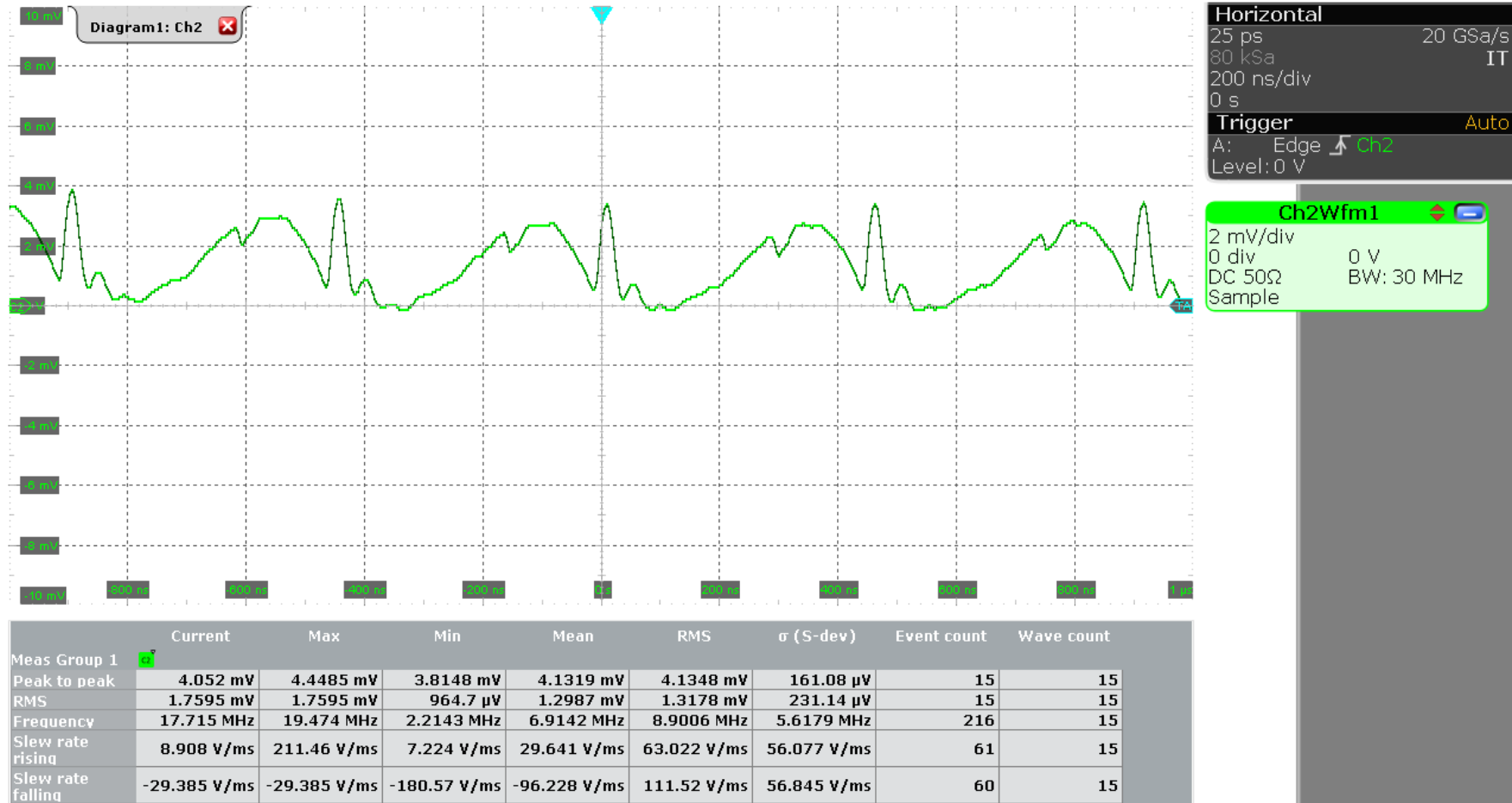
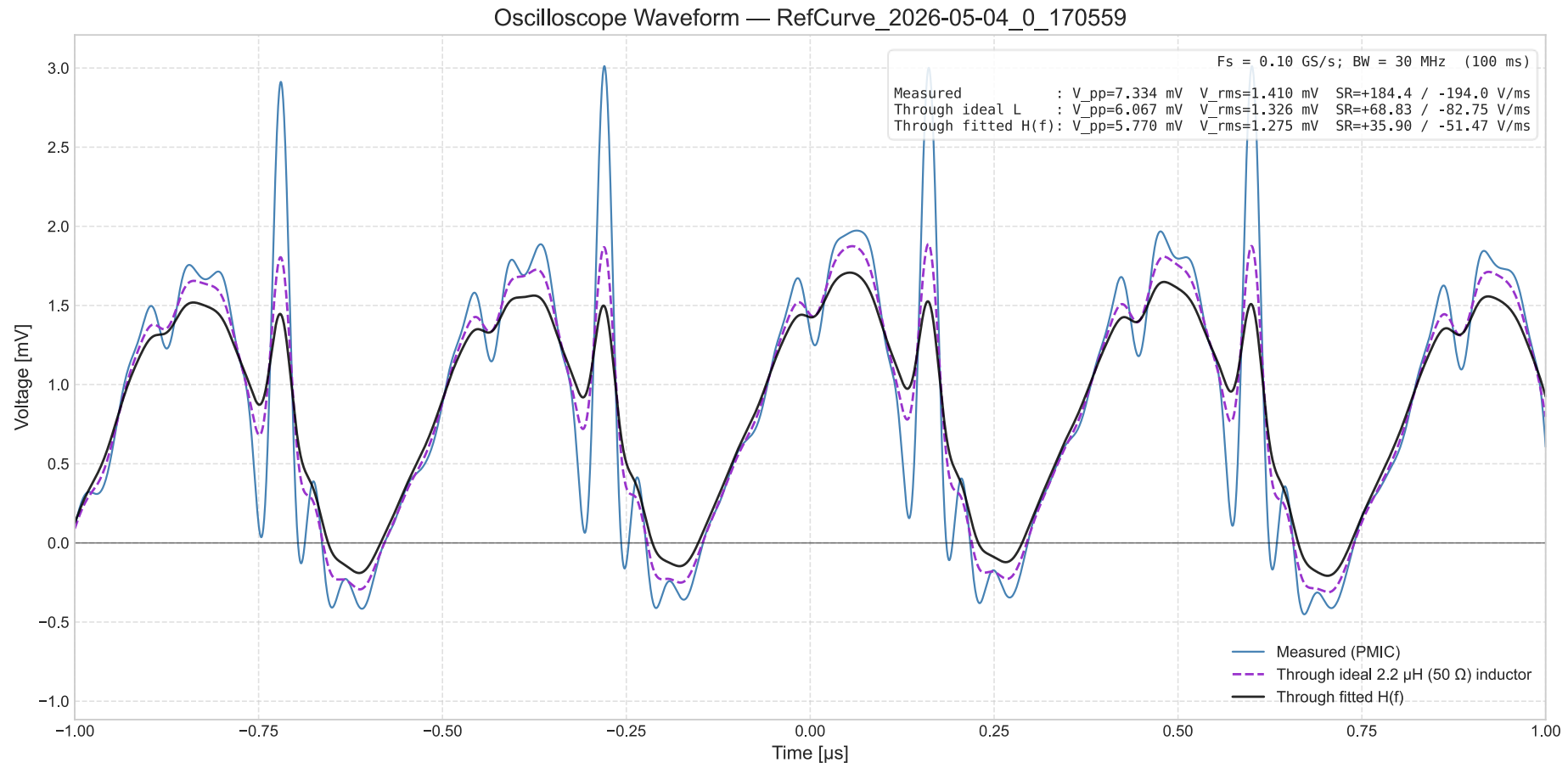

Photo of transmission line probe

Oscilloscope Measurement



Time Domain – Applied Transfer Function



Conclusion

- Attenuation of the PoC filter is lower than first simulations suggested.
- Noise coupling shown from PMIC to MDI is still only an estimate and depends on Z_{PSE} and Z_{PD} .
- We should either adopt the noise specifications from Clause 104 or specify a dedicated MDI voltage ripple limit over frequency.

Thank You!