

Further Considerations Regarding a 1 Gb/s Uplink Rate

June 2026

Ad-hoc

Tony Schedl, BMW

Ahmad Chini, Broadcom

Scott Muma, Microchip

Supporters

- Mehmet Tazebay, Broadcom
- Kamal Dalmia, NXP
- Frank Wang, Realtek
- Dongok Kim, Hyundai
- Hideki Goto, Toyota
- Gumersindo Veloso, BMW
- Yasuhiro Kotani - DENSO
- David Bollati, C&S
- Ramanjit Ahuja, Onsemi
- Debu Pal, Onsemi
- Christian Liebl, Aumovio
- Mathias Kleinwaechter - In-tech

Background

- ❑ The 802.3dm has specified numerous asymmetric data rates up to 10Gbps with 100Mbps in the reverse path. Several participants in 802.3dm task force have mentioned the value of specifying 1 Gb/s in the reverse path.
 - The PAR allows up to 10Gbps links with a “lower data rate” in the reverse direction.
 - 802.3dm defines two independent clauses; Clause 191 and Clause 192. A proposal to extend clause 192 , does not affect Clause 191.
- ❑ There are applications that are mentioned to use 1Gbps in the reverse path:
https://www.ieee802.org/3/ISAAC/public/100423/matheus_ISAAC_01c_10042023.pdf
Application examples are described in this presentation as well.
- ❑ It is decided that additions to the clause 192 draft reuses the existing specifications and should not cause extra delay to completion of the 802.3dm specification.
- ❑ Changes are proposed for draft 2.0
- ❑ Task force members are welcome to contribute to this proposal.

1 Gb/s LS Path Specification Proposal for Clause 192

- ❑ To support the optional 1 Gb/s in the LS path, the burst length in the HS path is shortened, allowing for longer bursts in the LS path.

- ❑ The proposal uses the existing specification to support the new rates with minimal added logic.
 - Existing baud rates of 3G and 6G
 - Same TDD Cycle
 - Same FEC Coding, Interleaving and Decoding
 - Same 64/65 Encoding
 - Existing Scramblers, Modulations and Signal levels as previously specified
 - Same Electrical specifications (PSD, Droop, Jitter, Distortion)
 - Same Link segments
 - Same State machines
 - Same Link-up process

- ❑ HS path of 7.5Gbps and 5Gbps are specified with 1Gbps LS path.

7.5Gbps/1Gbps Specification For Clause 192

LS path: 1Gbps

6Gbaud-PAM2, 5 x RS (128, 122), L=2.

This is same as HS 5Gbps specification but a shorter burst of 1706.66ns length.

Total Refresh Period

368ns as in the current specifications

Total IBG Period

352ns as in the current specifications

HS path: 7.5Gbps

6Gbaud-PAM4, 25 x RS (128,122), L=3.

This is same as HS 7.5Gbps specification other than the scrambler and modulation that follows HS 10Gbps and a shorter burst duration of 6400ns.

Additional Capacity

There is a 773.33ns extra capacity;

Add 1 x RS (128,122), L=2 to LS path plus a padding of 32Bytes

Add 1 x RS (128,122), L=3 to HS path plus a padding of 200Bytes

* L is the interleaving degree

5Gbps/1Gbps Specification For Clause 192

LS path: 1Gbps

6Gbaud-PAM2, 5 x RS (128, 122), L=2.

This is same as HS 5Gbps specification but a shorter burst of 1706.66ns length.

Total Refresh Period

368ns as in the current specifications

Total IBG Period

352ns as in the current specifications

HS path: 5Gbps

6Gbaud-PAM3(3B2T), 25 x RS (128,122), L=2.

This is same as HS 5Gbps specification other than the scrambler and modulation that follows HS 7.5Gbps and a shorter burst duration of 5688.88ns.

Additional Capacity

There is a 1484.44ns extra capacity;

Add 1 x RS (128,122), L=2 to LS path plus a padding of 32Bytes

Add 5 x RS (128,122), L=2 to HS path plus a padding of 54Bytes

1Gbps Bursts in LS Path with 7.5Gbps or 5Gbps Bursts in HS Path

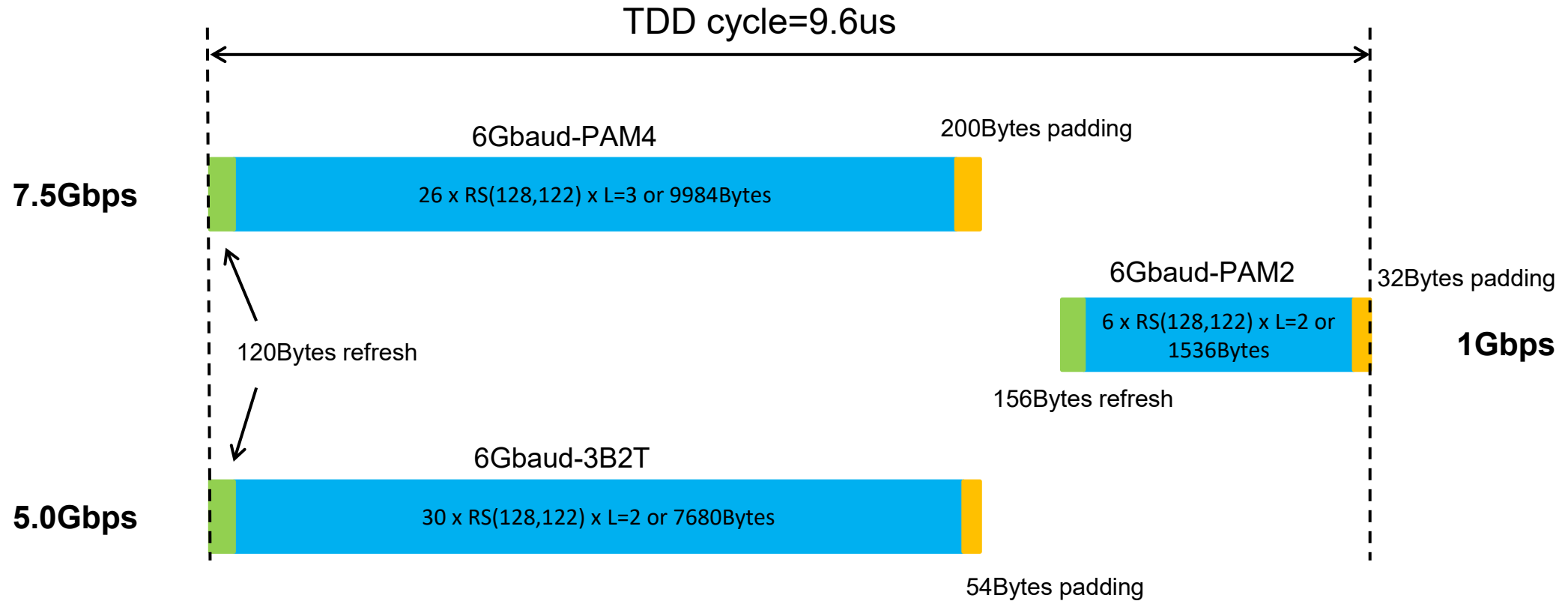

* There is an extra coded capacity which can be used for other user-defined purposes or left idle.

Example 1: Cameras in the Zone Roof Combined with Backend Communication

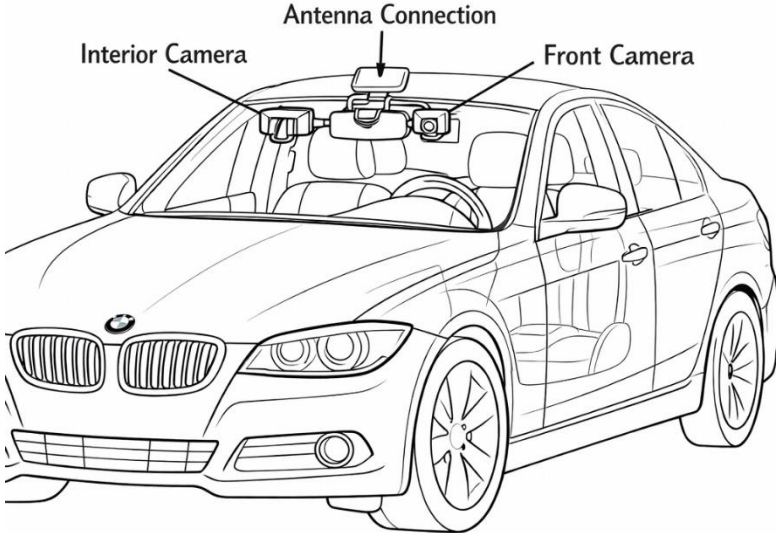
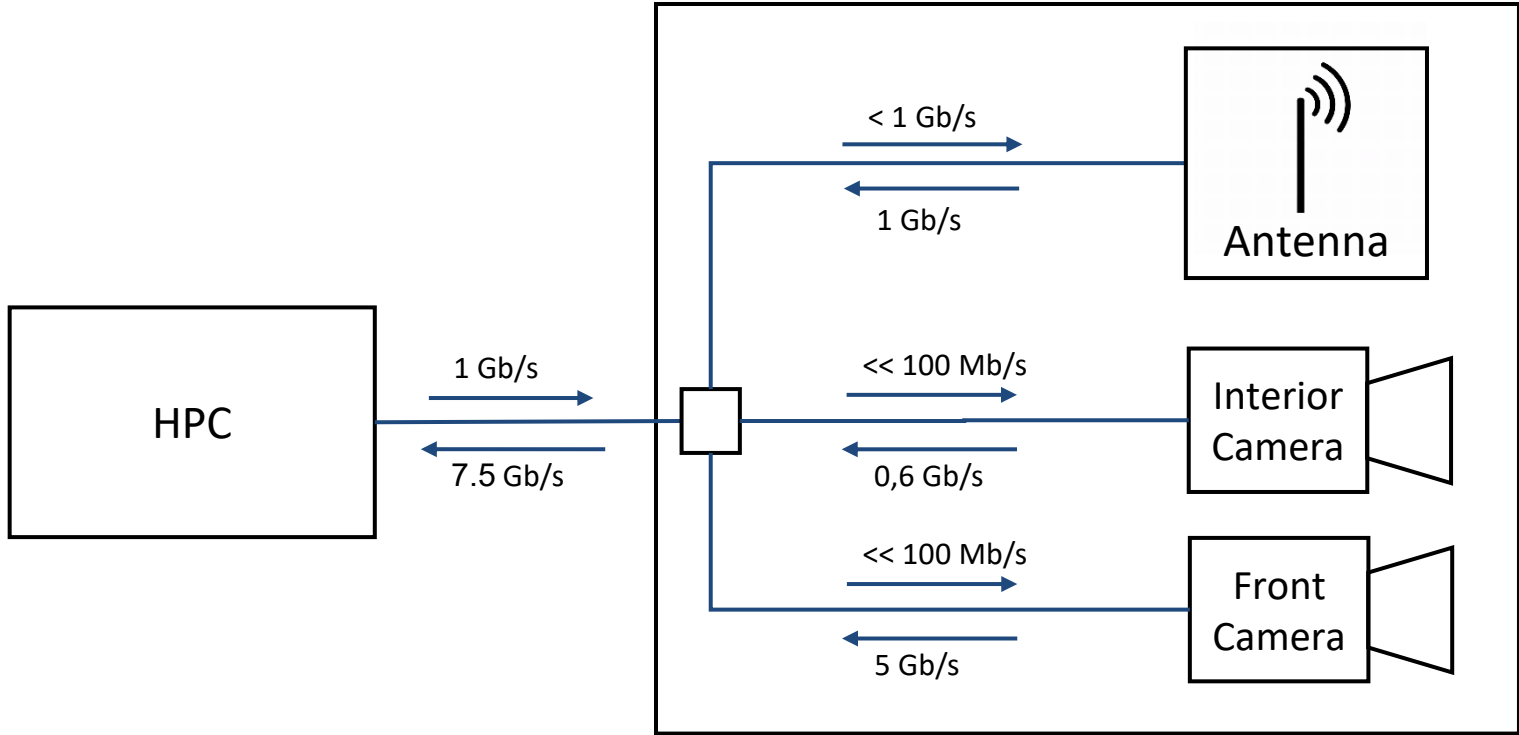

Example 2a: Rear Seat Entertainment with Two Displays and Video Calling

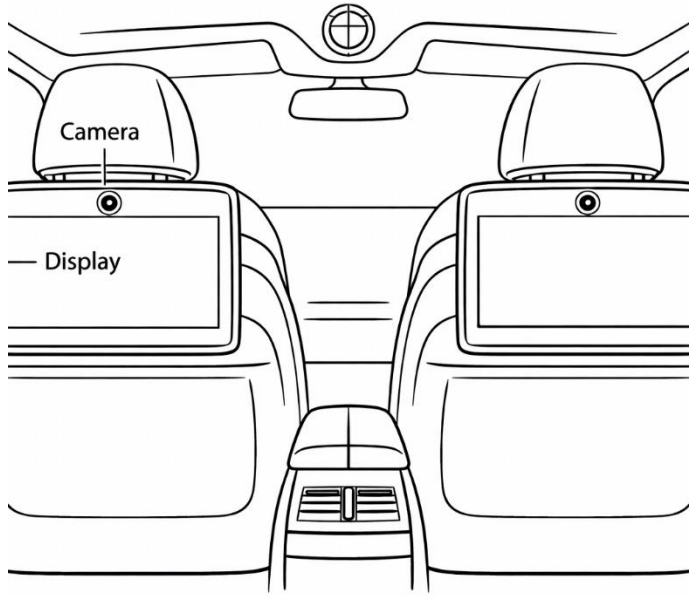
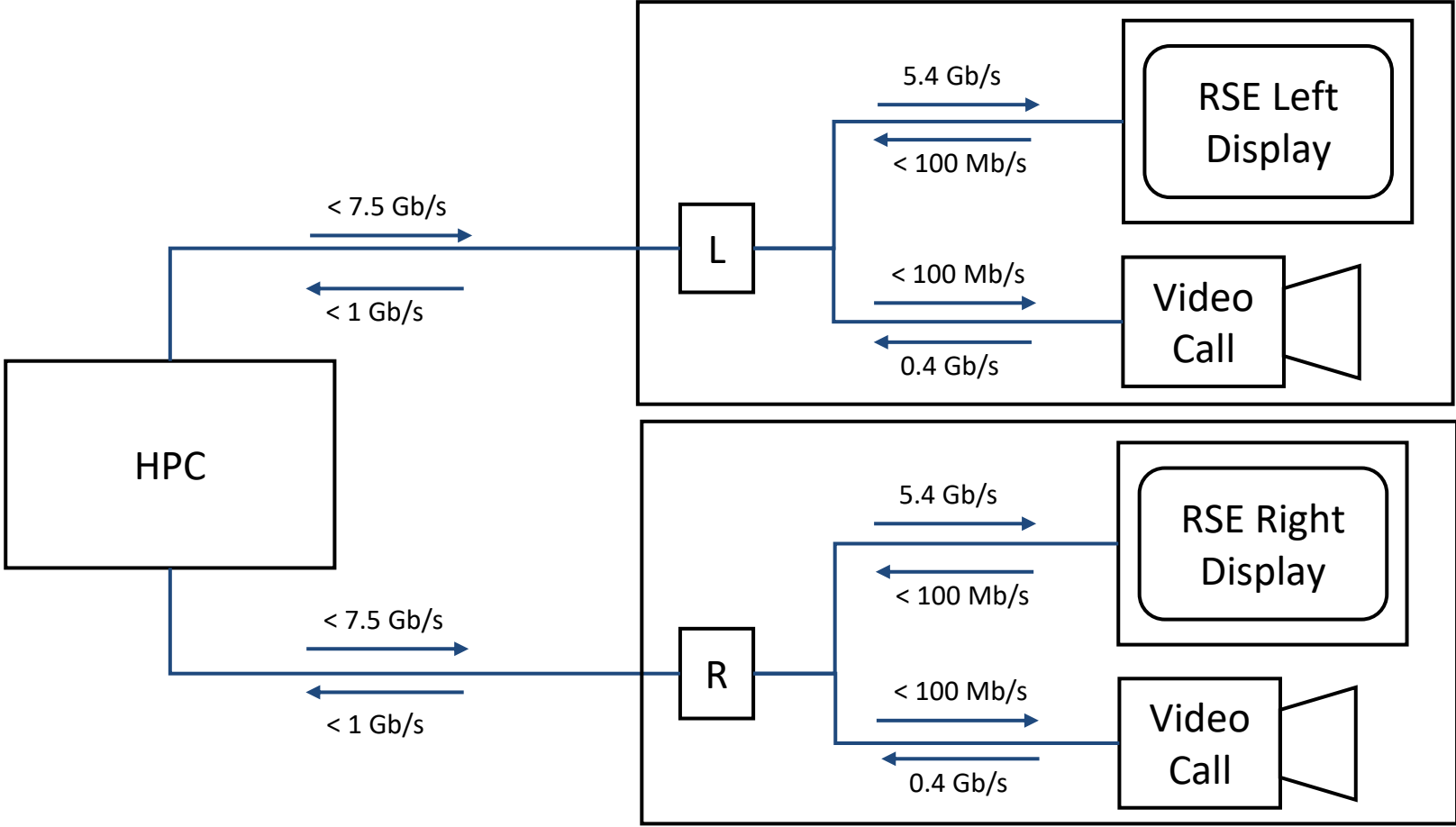

Example 2b: Rear Seat Entertainment with Panorama Display and Integrated Video Calling

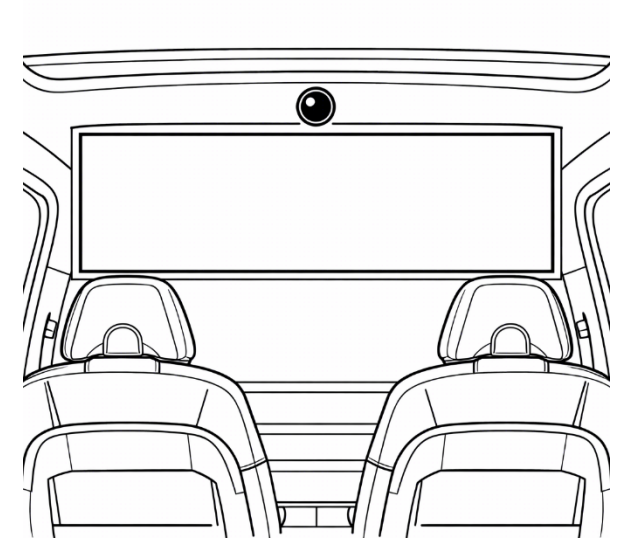
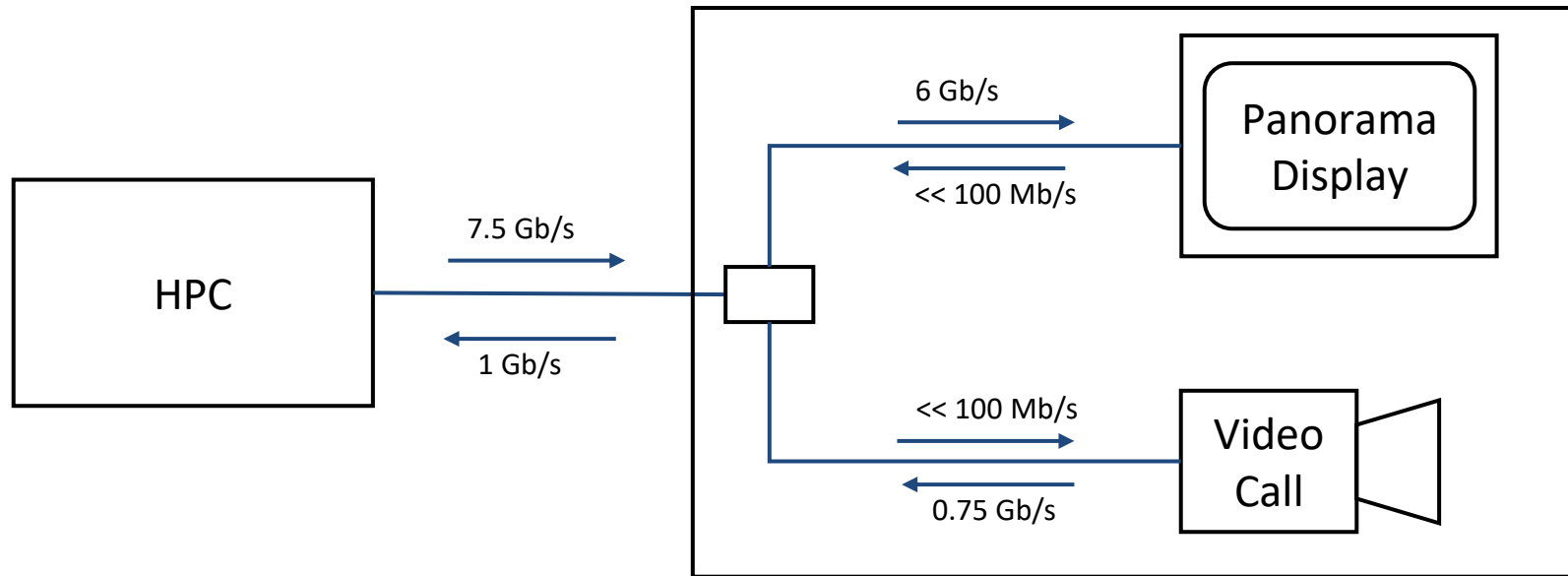

Conclusions

- ❑ The PAR allows asymmetric links with 1 Gb/s in the reverse path.
- ❑ Changes proposed to clause 192 to support 7.5Gbps+1Gbps and 5Gbps+1Gbps.
- ❑ The proposed additions to the clause 192 re-uses the existing 802.3dm draft specification and should not affect the 802.3dm completion timeline.
- ❑ The proposed changes do not affect clause 191.
- ❑ There are use cases for 1Gbps in the reverse link that profit from the proposed specification.

Thank You

Typical Bandwidth Requirements for Cameras and Displays

- ❑ Typical interior camera (Full HD @ 30fps, 10bits/pixel):

- ❑ $1920 \times 1080 = 2,073,600$ pixels/frame
- ❑ $2,073,600 \times 30 \times 10 = 0.62$ Gb/s

- ❑ Typical front camera (4K @ 60fps, 10 bits/pixel):

- ❑ $3840 \times 2160 = 8,294,400$ pixels/frame
- ❑ $8,294,400 \times 60 \times 10 = 4.98$ Gb/s

- ❑ Typical video call camera for RSE (HD, 30 fps, 12 bits/pixel):

- ❑ $1280 \times 720 = 921,760$ pixels
- ❑ $921,760 \times 30 \times 12 \times 1.2$ (overhead) = 0.41 Gb/s

- ❑ Typical video call camera integrated in panorama displays (Full HD, 30 fps, 12 bits/pixel):

- ❑ $1920 \times 1080 = 2,073,600$ pixels/frame
- ❑ $2,073,600 \times 30 \times 12 = 0.75$ Gb/s

- ❑ Typical RSE display (Full HD, 60 Hz, 36 bits/pixel):

- ❑ $1920 \times 1080 = 2,073,600$ pixels
- ❑ $2,073,600 \times 60 \times 36 \times 1.2$ (overhead) = 5.38 Gb/s

- ❑ Typical panorama display (UW, 60 Hz, 24 bits/pixel):

- ❑ $3840 \times 1080 = 4,147,200$ pixels
- ❑ $4,147,200 \times 60 \times 24 = 5.97$ Gb/s

IEEE802.3dm Scope Compatibility

- ❑ **From the PAR:** “The scope of this project is to specify additions to and appropriate modifications of IEEE Std 802.3 to add Physical Layer specifications and management parameters for electrical media and operating conditions that are optimized for automotive end-node camera links for operation up to 10 Gb/s in one direction and with a lower data rate in the other direction.”
- ❑ Presentation https://www.ieee802.org/3/dm/public/0326/gorshe_3dm_02a_0326.pdf explained why there is no need to define an equivalent 7.5 Gb/s MAC because the MAC is inherently rate-less, which was the basis for P802.3dm specifying using XGMII for the 100 Mb/s interface
- ❑ In response to a request, David Law provided the following opinion:
 - ❑ A MAC can support any aggregate data rate less than or equal to its MAC data rate.
 - ❑ The MAC can operate at any aggregate data rate, but enforces a 96 BT IPG at its data rate
 - ❑ The RS may extend the IPG for lower data rates, but cannot shorten it for higher data rates
 - ❑ Assuming the RS supports it, a 7.5 Gb/s PHY will operate correctly with a 10 Gb/s MAC
- ❑ **In summary, a P802.3dm high-speed rate of 7.5 Gb/s can use the existing 10 Gb/s MAC definition**