

EFM Copper

PHY Management and PMD Control

EFM March, 2002

Scott Simon
(Cisco Systems, Inc.)

Topics

- **Recap of Raleigh PMD control discussion**
- **MIB, the MDIO and PMD parameters**
- **PMD Control and G.994**
- **Next steps**

PMD: Physical Medium Dependent PHY sublayer

Topics from Raleigh

- **PMD Control needed for EFM**
 - Band plan, bits/Hz, TX power, interleaver depth, etc
- **Control of remote PMD**
 - NT (CPE) device always acts as a slave to the LT (Concentrator)
- **Primitive start-up mode**
 - Link is initially established with a robust, common set of PMD parameters
- **PMD parameters in the MIB. . .**

Simple Example

- 1. Host (DSLAM, switch, etc. . .) configured for various “profiles”**
Each profile contains PMD settings for a particular environment. **EXAMPLES:**
PROFILE A: long reach, low bit rate (small band, sparse constellation)
PROFILE B: short reach, noise immune (large band, sparse constellation, deep interleaver, higher TX power)
- 2. Host sets each LT port PMD parameters to primitive mode via MDIO**
Link established with NT in primitive mode
- 3. Host downloads profile settings to NT using OAM channel**
Host instructs NT to switch to profile mode
- 4. Host sets LT PMD settings to profile mode**
Link established in new mode
- 5. If link goes down, each side reverts to primitive mode and waits for link**

Simple Example

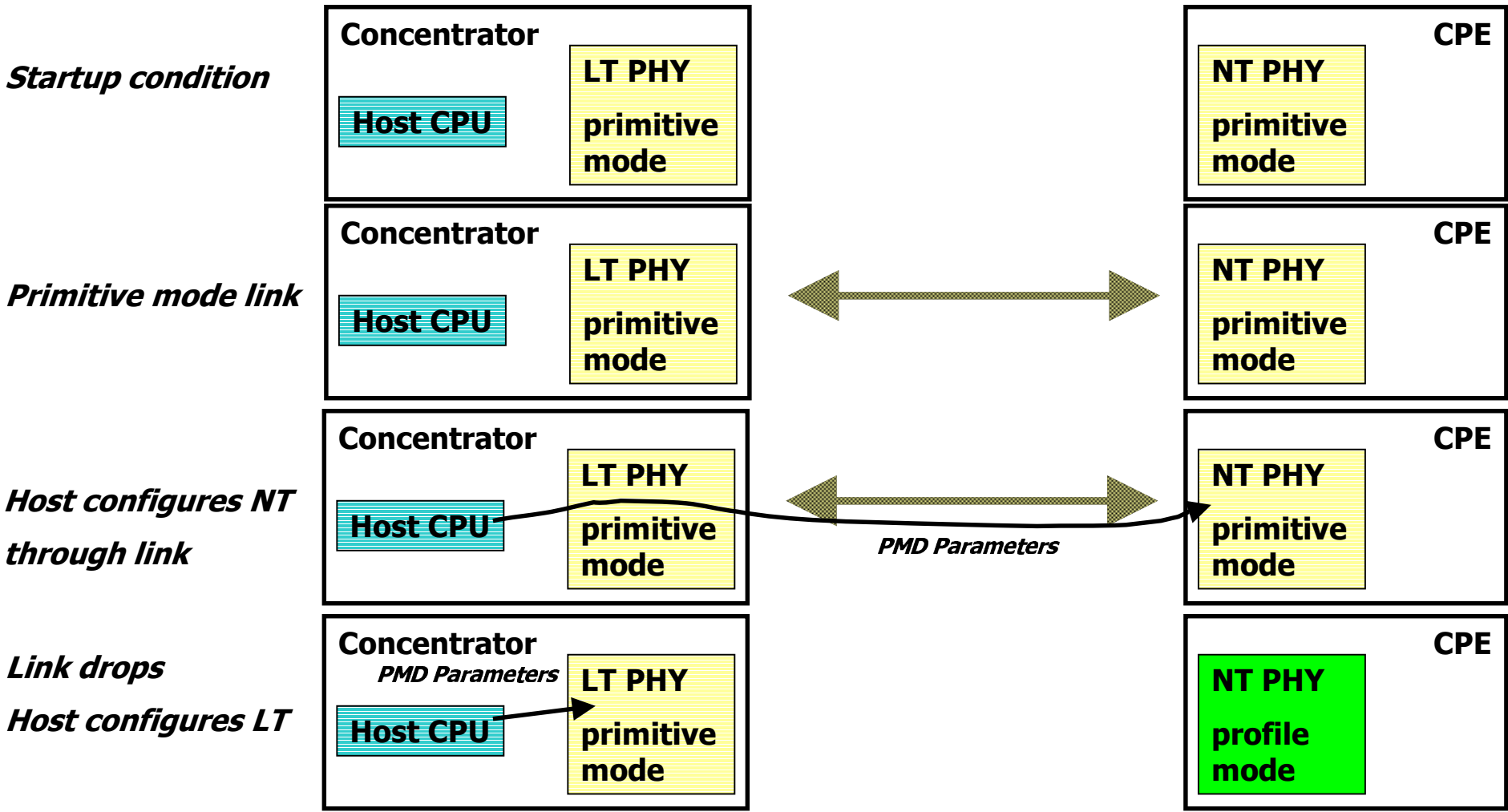

Simple Example

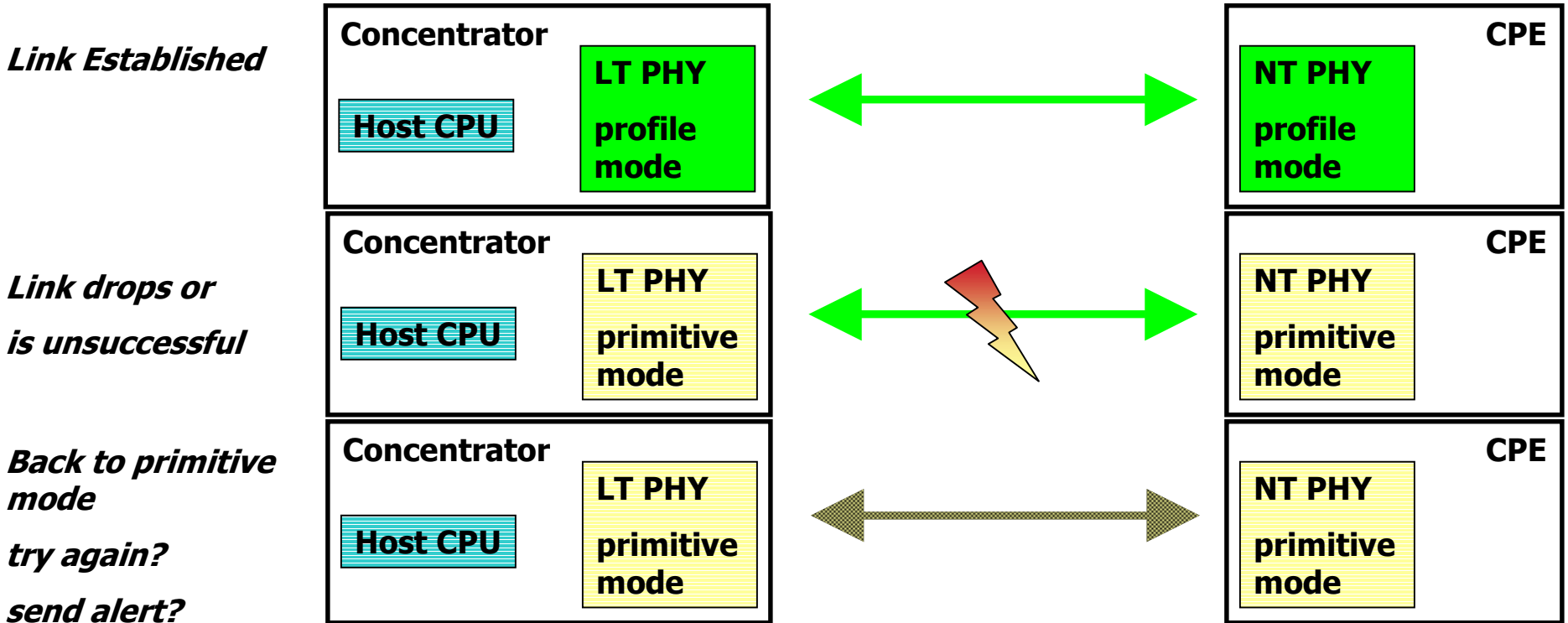

Ethernet Management 101

- 802.3 Clauses 5, 30 defines manageable objects for Ethernet commonly misnomered the “Ethernet MIB”: terse, but confusing
Management Information Base: “A repository of information to describe the operation of a specific network device”
- The Ethernet MIB is a list that describes the state objects on an Ethernet PHY
 - Manageables and Observables
 - Closely related to PHY registers
 - Objects must not be derived from other objects
- This is completely separate from the well-known SNMP MIB that a device presents to the outside world

Ethernet Management 102

- 802.3 already has a MIB, which contains PHY and MAC control
- 802.3ah_{Cu} will need to define extensions to this MIB that pertain to our specific functionality

PMD parameters, link aggregation, etc.

include management of LT and NT

- These manageable objects can be accessed through an arbitrary “management interface”

802.3 typically uses MDIO

We propose using the 802.3ae Clause 45 MDIO extension to provide enough register space and addressing capability (see [turner_1_0901.pdf](#))

System Management Example

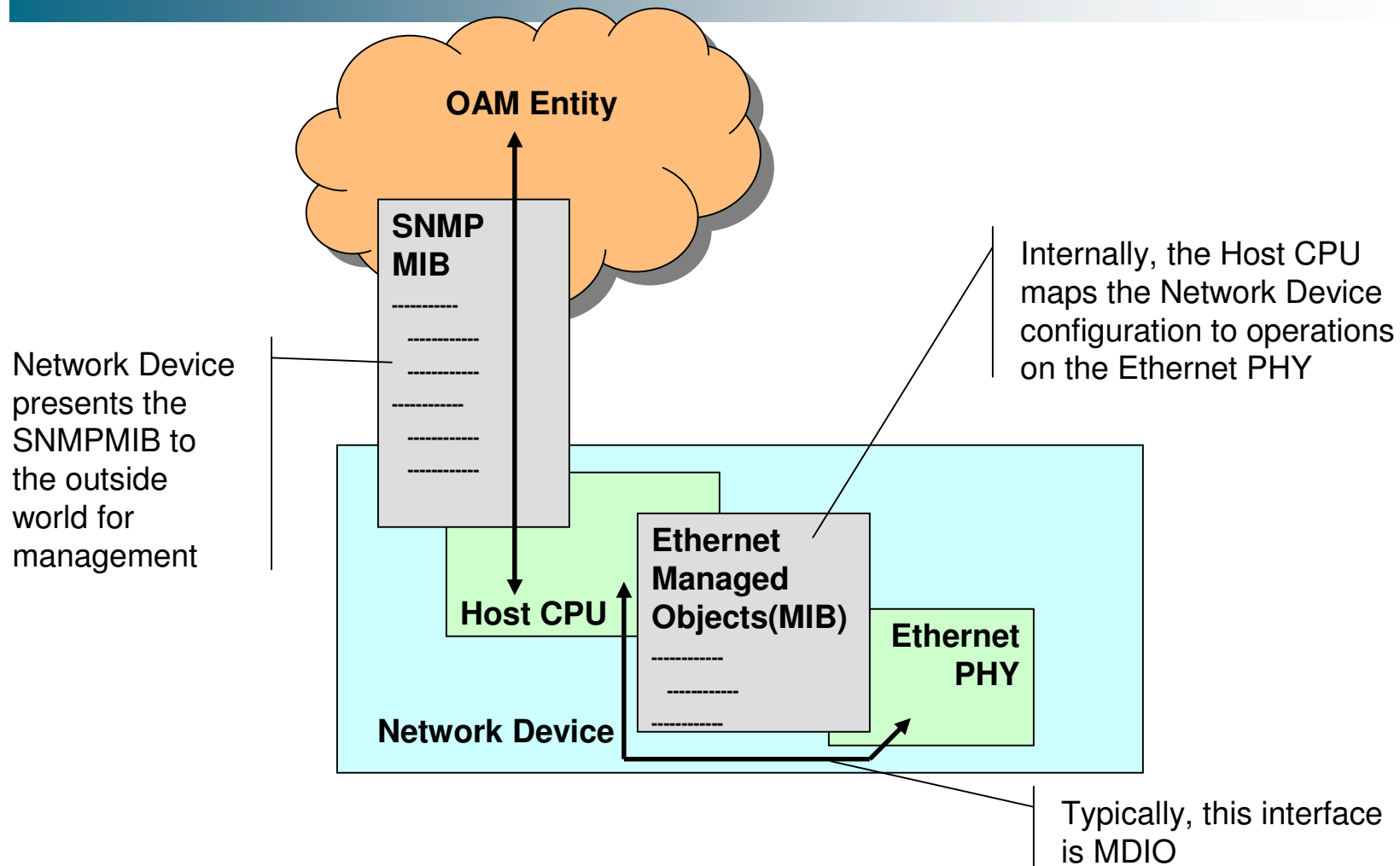

Control of remote PMD

- All PMD parameters on NT controlled from LT host
Uses OAM channel (VOC/EOC)
- LT host has total control of PMD algorithms
Plug-n-play CPEs
No need to restrict handshake or algorithms
CPE can be made as simple as possible
- Remote PMD parameters appear in local MIB
Accessible through MDIO

“Primitive” start-up mode

- **All NT & LT devices start in primitive mode**
 - Subset of operational modes,
 - Only the control channel is required, the data channel is optional
- **Primitive mode should always make link**
 - Narrow spectrum (universal spectral compatibility)
 - Lowest bits/hertz
 - i.e., very high noise margin
- **Once link is established, host controls PMDs**
 - Host can interrogate CPE capabilities then initiates normal operation in “Full” functionality mode
 - Change local & remote according to regional regulations
- **Timeout falls back to primitive mode**
 - If full link won't come up or if link is lost

Primitive Mode and G.994

- Proposal does not preclude use of G.994
- G.994 can be used to establish initial primitive mode link
 - We'll need to identify code points and carrier sets for EFM Cu
- G.994 can carry capabilities and parameters over the VOC/EOC
- G.994 not necessarily required for this scheme either
 - Standard can explicitly specify primitive mode parameters and the host takes over from there
- G.994 is initiated by the CPE side
 - this is at issue with the master/slave model
- G.994 is not complete

More on Remote PMD Control

- Need to decide how much functionality is left up to the CPE PHY and how much is controlled by the Host
- Goals:
 - Keep CPE as simple as possible
 - Allow Host system (LT) flexibility and control
 - Ensure interoperability
 - Avoid excessive management of the CPE
- **DMT Example:** The target band plan and bit rates might be controlled by the Host, but the NT decides on its own what sub-carriers have poor SNR.
- **Key Point:** Whatever is NOT under the control of the Host system (LT) must be FULLY SPECIFIED by 802.3ah_{Cu} to insure interoperability and forwards/backwards compatibility

Basic Rate Adaptive Example

Same mechanisms as simple example. Only host behavior changes:

1. LT and NT link in primitive mode
2. Host evaluates line condition based on parameters reported by PHY (SNR, RS errors, etc. . .)
3. Host sets NT PHY to a some configuration
might be best guess or optimized by steps below
4. Host sets LT PHY to complementary configuration.
5. Link established?
NO: Host adapts parameters for better margin. Go to step 1
YES: Host continues to evaluate line condition, may update parameters to optimize rate, reach, or latency. Back to step 3

Basic Adaptive Example

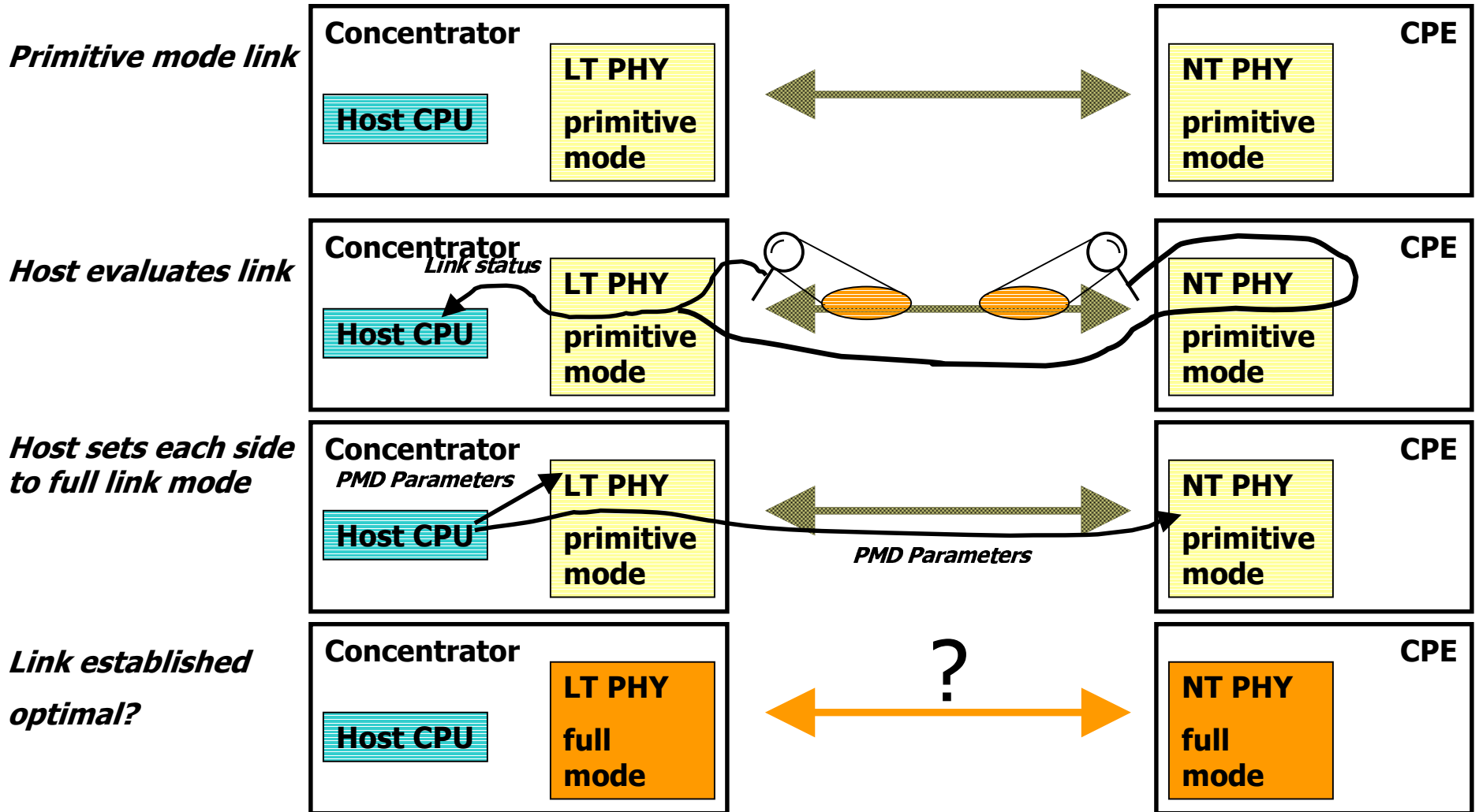

Basic Adaptive Example

Host continually evaluates link

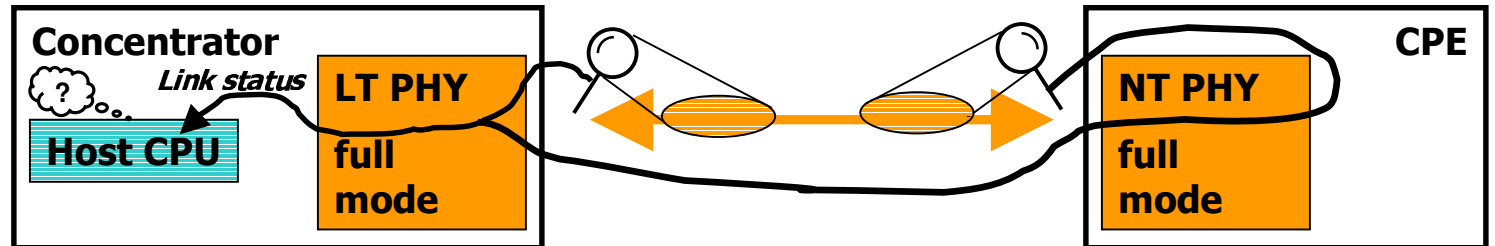

Host applies optimized settings

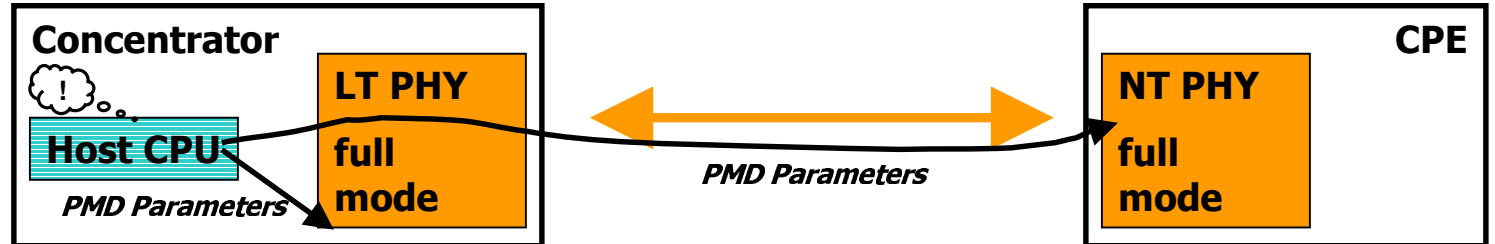

Full optimized link established

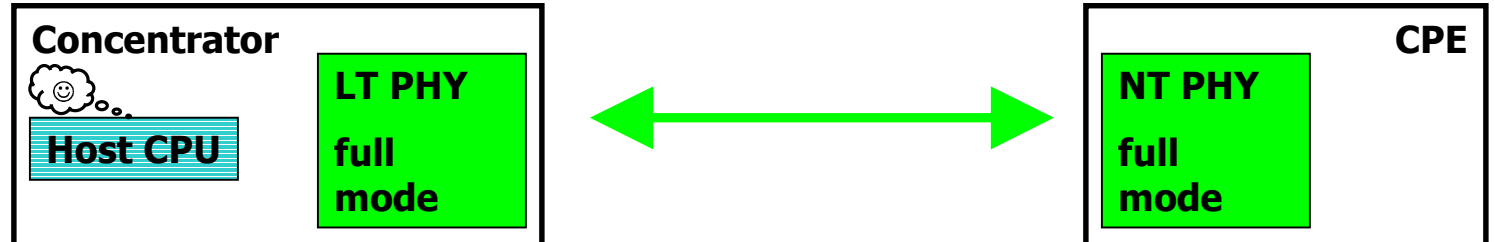

Host continues to monitor link for possible optimizations

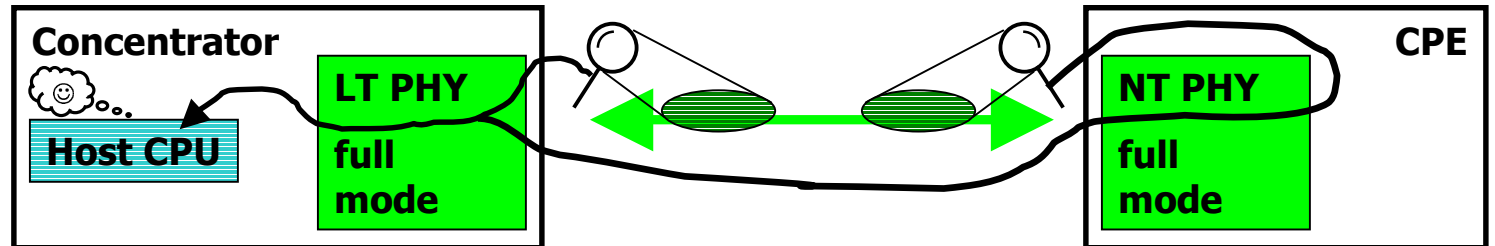

System-level Adaptive Example

- **High-level OAM entity maintains multiple ports to decide PMD parameters**
- **Looks at all lines in an installation**
- **Can operate on a single host or across multiple hosts**
- **Examples:**
 - create a “zipper” of DMT tones on FE/NEXting ports
 - tweak transmit based on site cabling properties (bridge taps, attenuation)
- **More stable than port-level adaptive methods**
 - the system intelligence can prevent race conditions when 2+ ports try to optimize against each other

System-level Adaptive Example

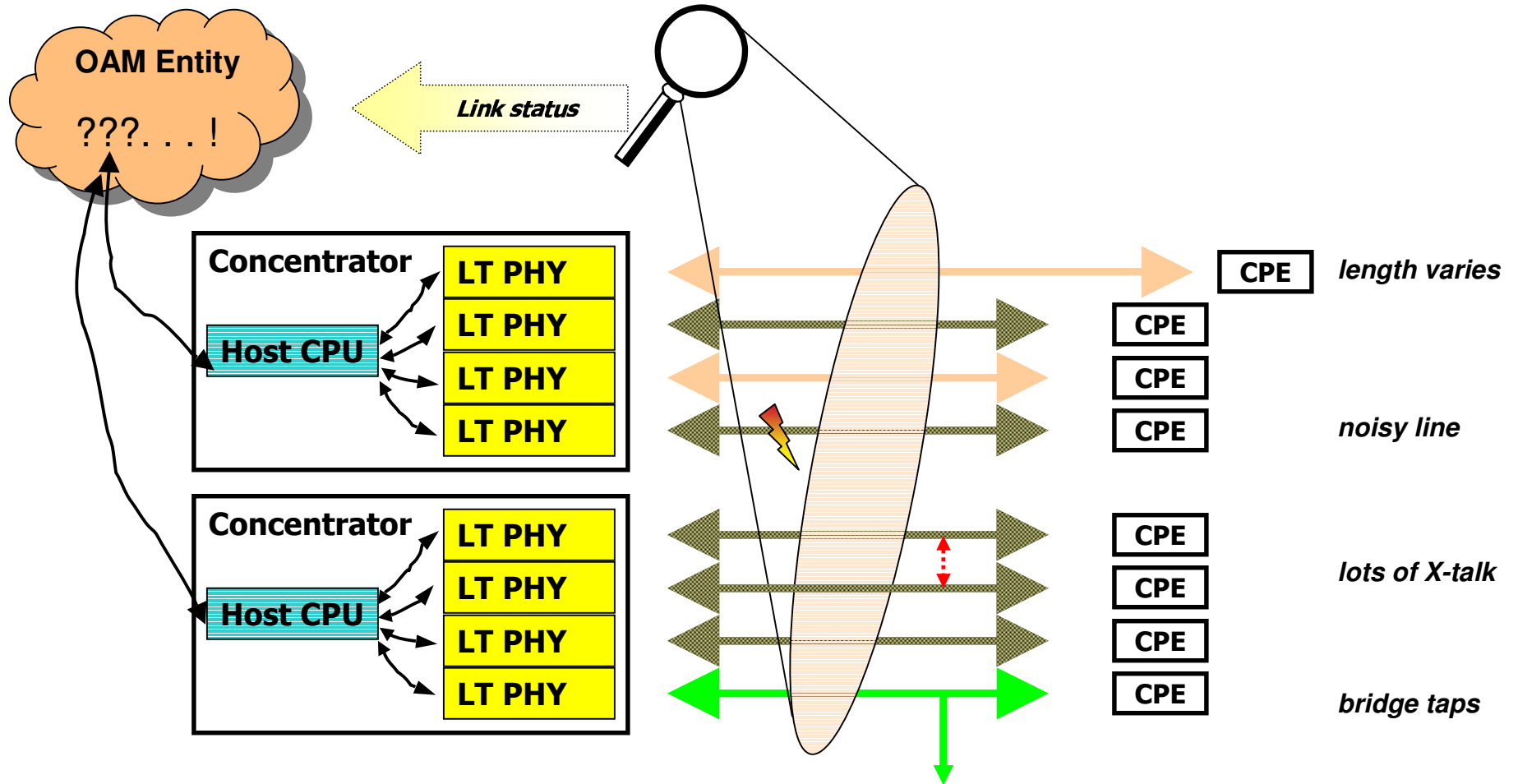

Summary

- **PMD control minimizes PHY state complexity**
 - Complexity moved to host, amortized over n-ports on concentrator
 - No need to fix PMD algorithms in standard
 - Easier to allow regional variation & regulation
- **PMD control through MIB and MDIO true to Ethernet.**
 - PHYs integrate with current model easily
- **LT host control of NT PMD simplifies interoperability**
 - Different vendors' proprietary features operate with any brand of CPE
 - No handshaking or negotiating required at PHY level
 - Lowers CPE complexity
- **Primitive mode is common baseline for advanced functionality**

Next Steps

- Define EFM_{Cu} managed objects
- Define PMD control registers
- Define primitive mode values
- Define primitive mode link acquisition sequence
 - If using G.994: code points and carrier sets