



IEEE 802.3 Ethernet Working Group Liaison Communication

Source: IEEE 802.3 Working Group¹

To: Dr. Walter P. von Pattay, Secretary - ISO/IEC JTC 1/SC 25/WG 3 (Walter@Pattay.com)

CC: Paul Nikolich, Chair, IEEE 802 LMSC (p.nikolich@ieee.org)

Adam Healey, Secretary, IEEE 802.3 Ethernet Working Group (adam.healey@lsi.com)

Alan Flatman, Liaison, ISO/IEC SC 25 WG 3 with IEEE 802.3 (a_flatman@tiscali.co.uk)

Subject: Liaison to ISO/IEC SC 25 WG 3 from IEEE 802.3 in response to 3N926

From: David Law – Chair, IEEE 802.3 Ethernet Working Group (dlaw@hp.com)

Approval: Agreed to at IEEE 802.3 Plenary meeting, San Diego, 15 July 2010

Dear Dr. von Pattay and members of ISO/IEC SC 25 WG 3,

Thank you for your liaison document 3N926 titled “*Request to IEEE 802.3 regarding optical return loss requirement for high data rate (1G and above) Ethernet*” requesting clarification on the reflection requirements in IEEE Std 802.3.

In your liaison document you asked four questions. The questions are repeated below interleaved with our responses.

Q1. Do we understand correctly that this 12 dB requirement includes the optical return loss from the connectors that are plugged into the equipment at each end of the channel?

There was also a Note: *Please note; the ISO/IEC 11801 channel does not include the performance of the connecting hardware at the equipment interface.*

A1. The 12 dB optical return loss tolerance parameter is used in two **transmitter** performance requirements (RIN and TDP) defined at TP2, as illustrated below. The 12dB value represents the return loss when the transmitter is connected to a receiver. At the receiver, the -12 dB reflectance requirement includes the connector.

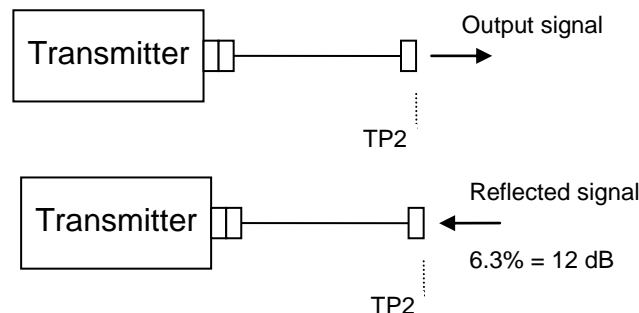

¹ This document solely represents the views of the IEEE 802.3 Working Group, and does not necessarily represent a position of the IEEE, the IEEE Standards Association, or IEEE 802.

Q2. Is it expected that these equipment interface connectors will consist of an open fibre end, i.e. the launch is via free space and not a fibre pigtail, and the receiver is open ended to the detector?

A2. Such implementations are not prohibited by the standard. The transmitter has to tolerate a 12 dB return loss at TP2 and is *independent* of the configuration of the transmitter. Likewise, the receiver reflectance is required to no more than than -12 dB independent of its configuration.

Q3. Does this requirement also include an allowance for reflections back from the receiver at the far end of the link?

A3. The 12 dB optical return loss tolerance represents the return loss when the transmitter is connected to a receiver – and therefore does include those reflections.

Q4. Do we understand correctly that the Rayleigh scattering from the installed fibre itself is included in this requirement?

A4. The 12 dB optical return loss tolerance represents the return loss when the transmitter is connected to a receiver – and therefore does include Rayleigh scattering.

We would also provide the following additional information.

The IEEE 802.3 standard for multimode optical fibre applications operating at 1G and above does not specify return loss for the combination of the channel and the receiver connected to it. However, the maximum discrete reflectance for optical connections is specified as -20 dB.

Sincerely,

David J. Law
Chair, IEEE 802.3 Ethernet Working Group
dlaw@hp.com