



IEEE P802.3ba 40Gb/s and 100Gb/s Ethernet

Opening Plenary Report

Vancouver, BC, Canada
March 2009

John D'Ambrosia
jdambrosia@ieee.org



IEEE P802.3ba Task Force Officers and Editors

<u>John D'Ambrosia</u>	Task Force Chair
<u>Ilango Ganga</u>	Task Force Chief Editor Editor – Clauses 1, 4, 80, Annexes A, 4A
<u>Mark Gustlin</u>	Chair, “Logic” Sub-task Force Editor – Clauses 81, 82
<u>Chris DiMinico</u>	Chair, “Cu” Sub-task Force Editor – Clause 85
<u>Pete Anslow</u>	Chair, “Optical” Sub-task Force Editor – Clause 88
<u>Hugh Barrass</u>	Editor – Clauses 30, 45
<u>Jonathan King</u>	Editor – Clause 87
<u>Arthur Marris</u>	Editor – Clauses 69, 73, 74, 84, Annexes 69A, 69B
<u>Steve Trowbridge</u>	Editor – Clause 83, Annex 83C
<u>Ryan Latchman</u>	Editor – Annex 83A, 83B Chair, “nAUI” Ad Hoc
<u>Piers Dawe</u>	Editor – Clause 86 Chair – “Statistical Eye” Ad Hoc
<u>Alessandro Barbieri</u>	Co-chair – Extended Reach Parallel MMF Ad Hoc
<u>John Petrilla</u>	Co-chair - Extended Reach Parallel MMF Ad Hoc
<u>George Oulundsen</u>	Task Force Secretary
<u>Frank Chang</u>	Task Force Web Master

Reflector and Web

- To subscribe to the IEEE P802.3ba Task Force reflector, send an email to:

ListServ@ieee.org

with the following in the body of the message (do not include “<>”):

***subscribe stds-802-3-hssg <yourfirstname> <yourlastname>
end***

- Send IEEE P802.3ba Task Force reflector messages to:

STDS-802-3-HSSG@listserv.ieee.org

- Task Force web page URL:

http://www.ieee802.org/3/ba/

IEEE P802.3ba Private Area

- URL: <http://www.ieee802.org/3/ba/private/>
 - Username: 802.3ba
 - Password: xxxxxxx
 - Password is case sensitive

- Note - The draft is posted for your review only, and neither the draft nor access information should be copied or redistributed to others in violation of document copyrights.

Task Force Approved Project Documents

■ PAR

- http://ieee802.org/3/ba/PAR/par_0308.pdf

■ 5 Criteria

- http://ieee802.org/3/ba/PAR/P802.3ba_5C_0908.pdf

■ Objectives

- http://ieee802.org/3/ba/PAR/P802.3ba_Objectives_0308.pdf

Task Force Objectives

- Support full-duplex operation only
- Preserve the 802.3 / Ethernet frame format utilizing the 802.3 MAC
- Preserve minimum and maximum FrameSize of current 802.3 standard
- Support a BER better than or equal to 10⁻¹² at the MAC/PLS service interface
- Provide appropriate support for OTN
- Support a MAC data rate of 40 Gb/s
- Provide Physical Layer specifications which support 40 Gb/s operation over:
 - at least 10km on SMF
 - at least 100m on OM3 MMF
 - at least 10m over a copper cable assembly
 - at least 1m over a backplane
- Support a MAC data rate of 100 Gb/s
- Provide Physical Layer specifications which support 100 Gb/s operation over:
 - at least 40km on SMF
 - at least 10km on SMF
 - at least 100m on OM3 MMF
 - at least 10m over a copper cable assembly

Adopted by IEEE P802.3ba and approved by 802.3 at Mar 2008 Plenary

Overview of IEEE 802.3 Standards Process (2/5) - Task Force Comment Phase

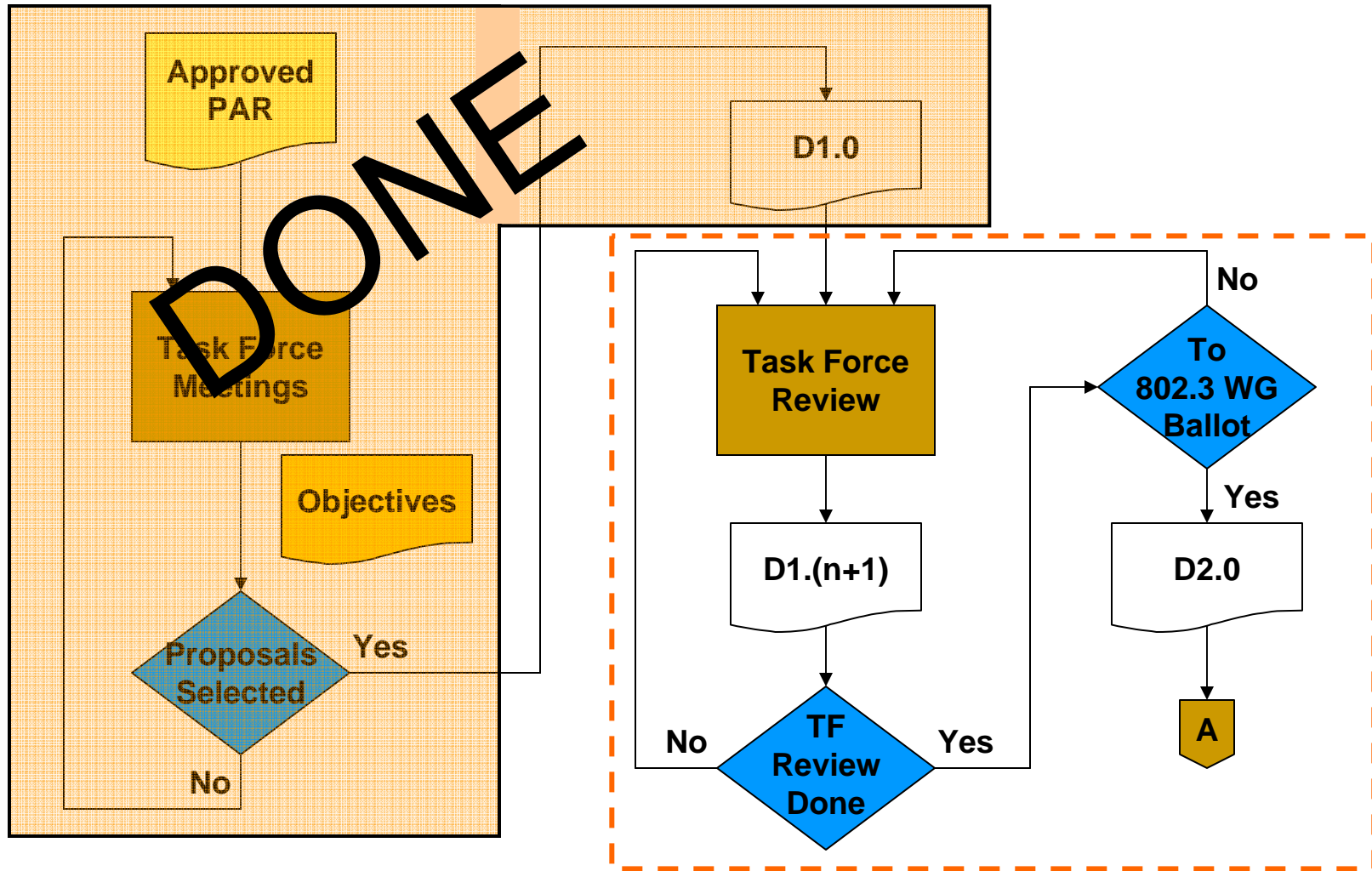

We Are Here

IEEE P802.3ba Task Force Timeline

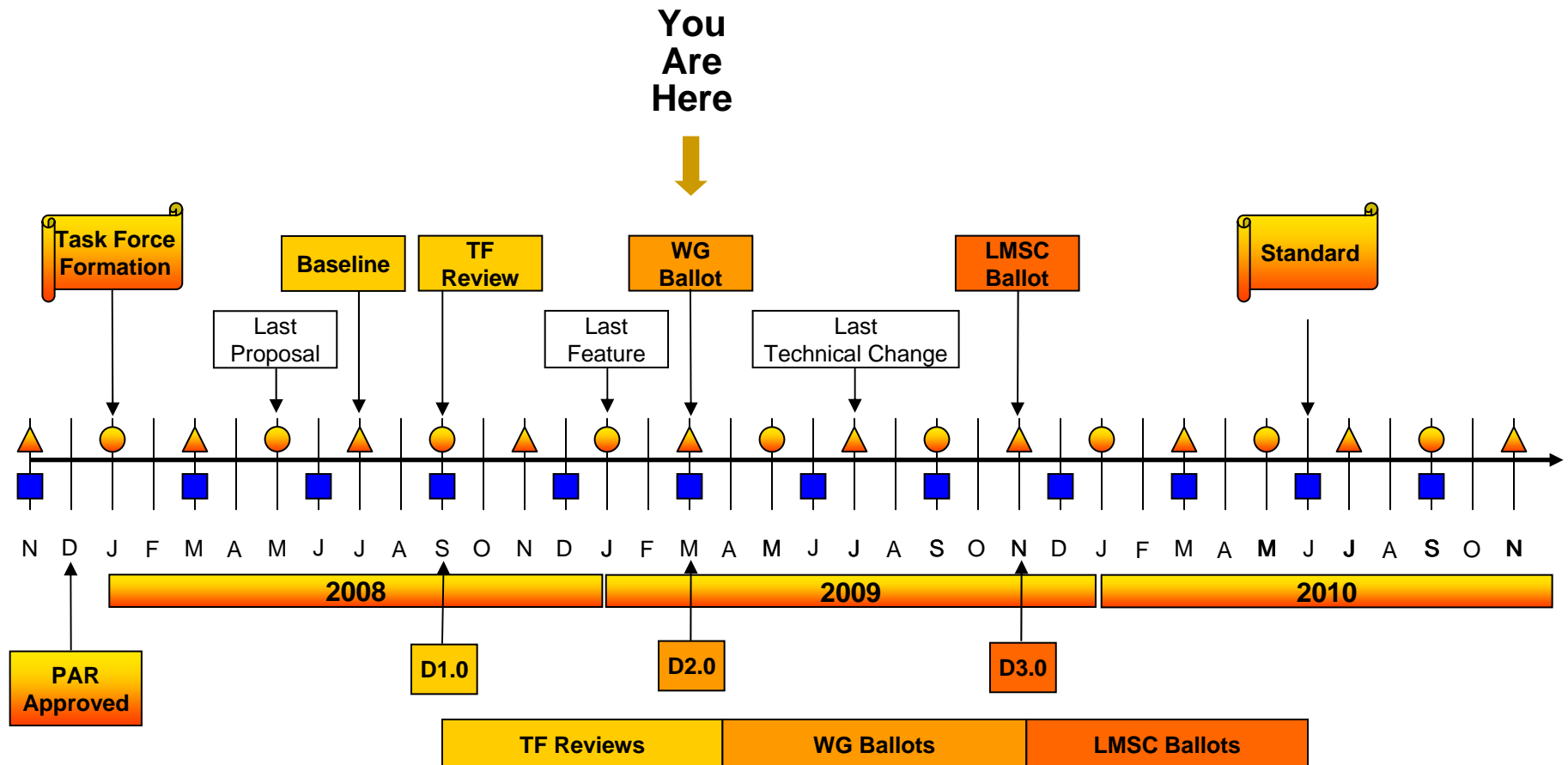

* Adopted by IEEE P802.3ba TF at March 08 Plenary

Legend	
▲	IEEE 802 Plenary
●	IEEE 802.3 Interim
■	IEEE-SA Standards Board

January Interim Meeting

- New Orleans, La
- Jan 13 - 16
- Hosted by AMCC: Thank You!
 - Special Thanks to Brad Booth and Kathy Ligon
- 85 Attendees
- 29 Presentations
- Liaison – ITU-T SG15: Appropriate Support for OTN
- Significant progress towards generating D1.2
 - Resolved all 485 T/TR comments
 - Added Annexes 83B (nAUI: Chip to Module) and 83C (PMA Partitioning)
 - Adopted PCS Lane Error Check (BIP-8) Proposal

Comments Received Against Draft 1.1

Description	Clause	Editor	T/TRs	E/ERs	Total
Front matter, MAC, 40G & 100G Intro	00, 01, A*, 4, 4A*, 80, 99	Ilango Ganga	27	18	45
Management	30, 30A*, 30B*, 45	Hugh Barrass	19	27	46
RS/MII and PCS	81, 82	Mark Gustlin	19	19	38
PMA	83	Steve Trowbridge	68	13	81
XLAUI and CAUI	83A	Ryan Latchman	63	14	77
Backplane KR4 related	69, 69A*, 69B, 73, 74, 84	Arthur Marris	28	13	41
Copper CR4 & CR10	85	Chris Di Minico	51	7	58
Optical SR4 & SR10	86	Piers Dawe	130	17	147
Optical 40G LR4	87	Jonathan King	43	5	48
Optical 100G LR4 & ER4	88	Pete Anslow	37	1	38
Total comments			485	134	619

* No comments on these clauses/annexes in D1.1

Motion #1 (From Jan 09 Mtg)

- Move to:
 - Charter the editorial team to create Draft 1.2, based on Draft 1.1 and all resolved comments (with unresolved editorial comments to be addressed by the editorial team), as recorded in “p8023ba-D11_Accepted_Responses_byClause.pdf”
 - Pre-submit Draft 1.2 to IEEE 802.3 in anticipation of requesting WG ballot at the March Plenary.
- Results
 - All in the room (y/n/a): 57/0/0
 - 802.3 voters (y/n/a): 40/0/0

Activities Between Meetings

- Draft 1.2 Released
 - To TF for comment on February 10
 - Comments due in on February 26
- Preview Copy (Draft 1.2) released to 802.3WG on February 23 in anticipation of requesting Working Group Ballot in March
- Requested consideration by IEEE-SA to do press release in anticipation of IEEE P802.3ba going to Working Group Ballot
 - Monday: 802 EC votes to support IEEE-SA press release
 - IEEE-SA has sent copy for information to ITU-T

Goals for the week

- Progress towards generating D2.0
 - Respond to comments
 - Hear technical presentations
- At the closing session, we will ask WG to initiate WG Ballot for IEEE P802.3ba –
 - Changes, if any are made to the previewed version of the draft, will be presented for WG review during the closing plenary immediately prior to the vote for approval to go to WG ballot (According to Section 2.8.2 of the IEEE 802.3 Operating Rules)
- Consider liaisons from
 - From Nov 08 - ISO/IEC JTC 1/SC 25/WG 3, Document #N882A
 - INCITS T11.2 Activities Report
- Lay groundwork for the next meeting

Comments Received Against D1.2

Description	Clause	Editor	T/TRs	E/ERs	Total
Front matter, MAC, 40G & 100G Intro	00, 01, A, 4, 4A, 80, 99	Ilango Ganga	1	0	1
Management	30, 45	Hugh Barrass	2	0	2
RS/MII and PCS	81, 82	Mark Gustlin	6	0	6
PMA	83, 83C	Steve Trowbridge	4	0	4
XLAUI/CAUI	83A	Ryan Latchman	20	15	35
XLAUI/CAUI module	83B	Ryan Latchman	18	0	18
Backplane KR4 related	69, 69A, 69B, 73, 74, 84	Arthur Marris	2	0	2
Copper CR4 & CR10	85	Chris Di Minico	27	6	33
Optical SR4 & SR10	86	Piers Dawe	17	8	25
Optical 40G LR4	87	Jonathan King	2	5	7
Optical 100G LR4 & ER4	88	Pete Anslow	5	2	7
Total comments			104	36	140

* Comments received on the clauses/annexes highlighted in blue

Meeting Map

	Mon	Tues	Wed	Thur	Fri	
8:00	SEC					
8:30						
9:00			All	All		All - Motions & Closing Business
9:30						
10:00						
10:30						
11:00	802.0 Plenary					
11:30						
12:00	Lunch	Lunch	Lunch	Lunch		
12:30						
13:00	802.3 Plenary	All	All	802.3 Plenary	SEC	
13:30						
14:00						
14:30						
15:00						
15:30						
16:00						
16:30						
17:00						
17:30						
18:00	Dinner	Dinner	Dinner			
18:30						
19:00	Tutorial #1	Tutorial #3	Social			
19:30						
20:00	Tutorial #2	Tutorial #4				
20:30						
21:00						
21:30						



Thank You!

