

1 **Replace Annex L with the following:**

2 **ANNEX-L**

3
4 **(Informative)**

5
6 **DTR Station and the C-Port in Station Emulation Mode**
7 **using the TXI Access Protocol**

8
9 **Join, Transmit and Monitor low-level FSMs**

10
11 **4 Mbit/s, 16 Mbit/s and the High Media Rate**

12 This annex contains the 9.2 FSMs illustrated by Figures 9.2-2 through 9.2-4, but with the level of detail
13 found in the 9.2 Station Operation Tables.

- 14 • Figure L-1 contains the Join FSM with the state transition detail of 9.2, Table 9.2-1.
15 • Figure L-2 contains the Transmit FSM with the state transition detail of 9.2, Table 9.2-2.
16 • Figure L-3 contains the Monitor FSM with the state transition detail of 9.2, Table 9.2-3.

17 The rules for these FSMs are identified in 9.1.1.9.

21

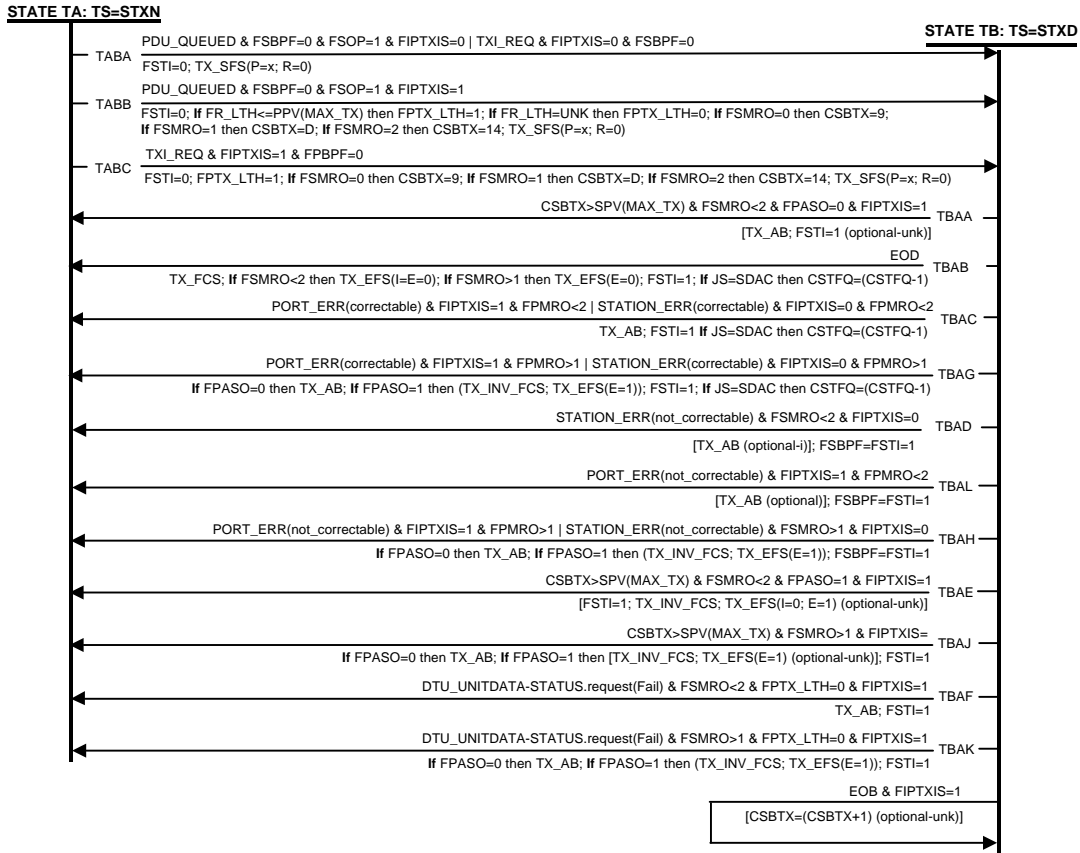

22
 23

Figure L-2 - TRANSMIT FSM

24

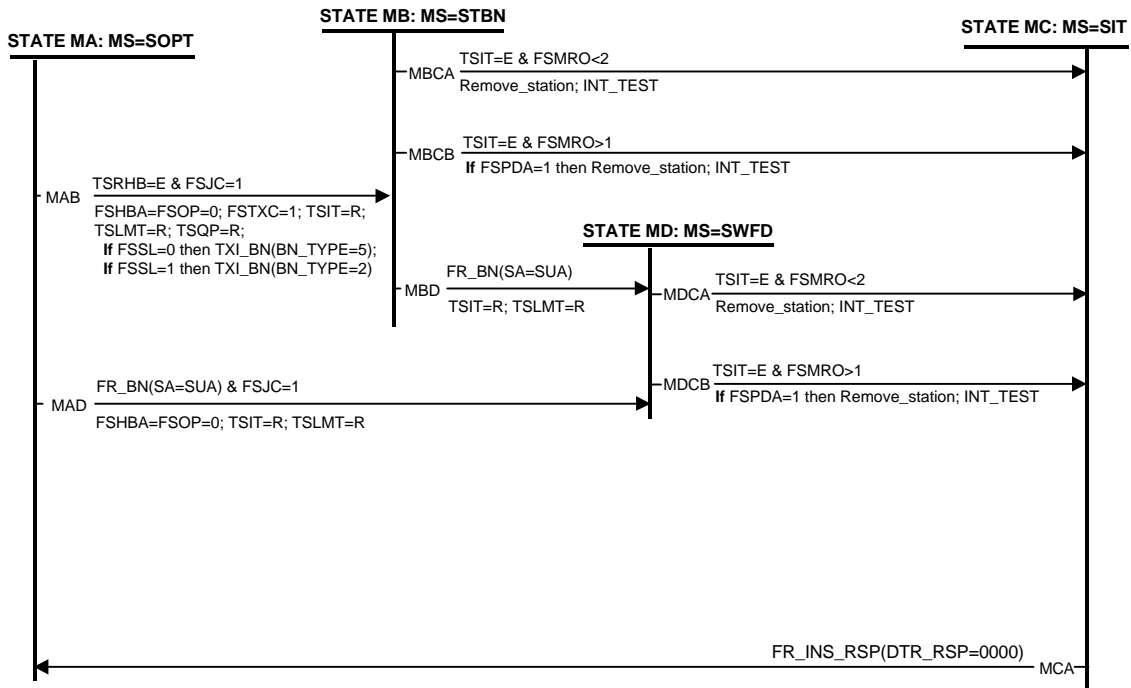

25
26

Figure L-3 - MONITOR FSM

27

⇒ End of Annex L